

# Service and Installation Rules of New South Wales

---

The electricity industry standard of best practice for  
customer connection services and installations

November 2016

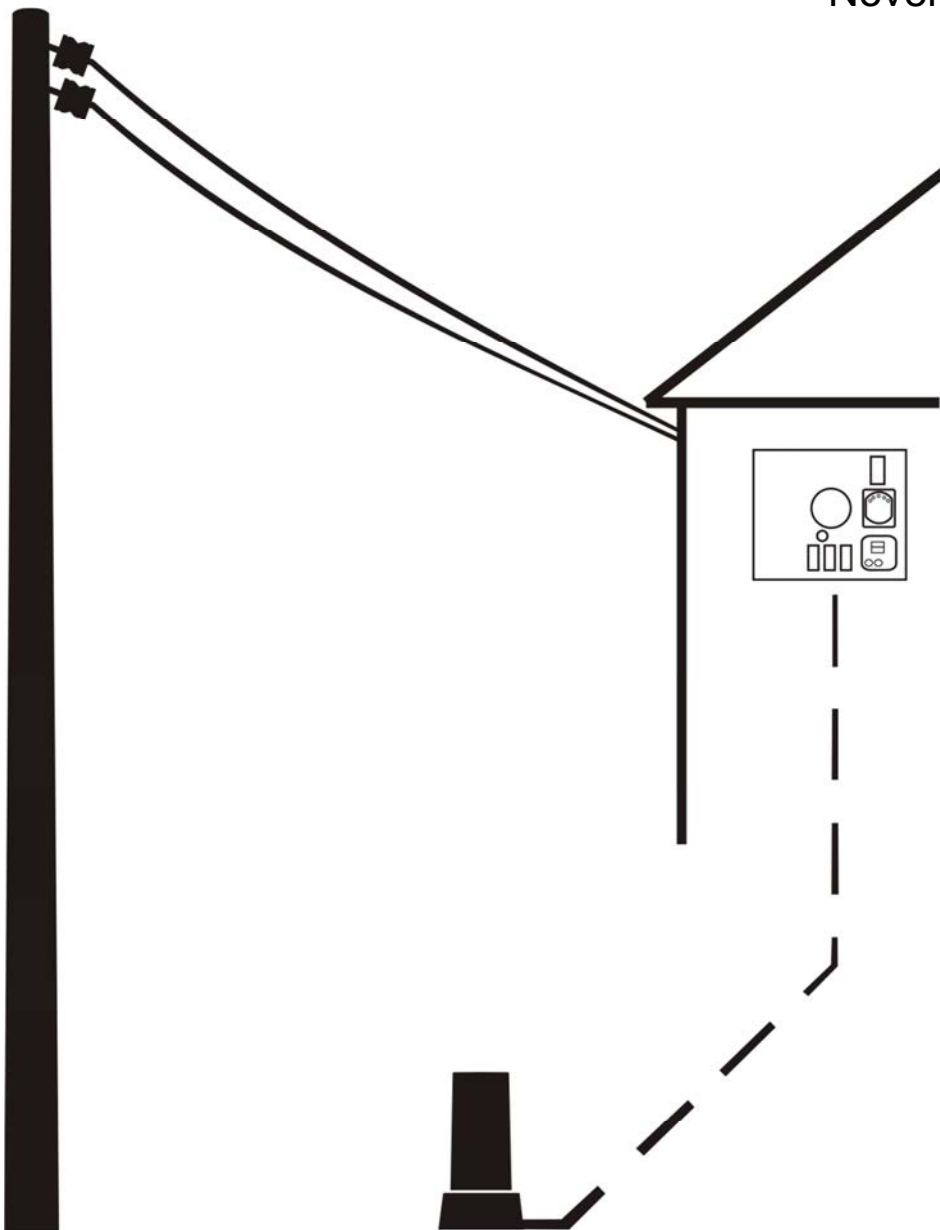



## Foreword

The Service and Installation Rules of New South Wales (the Rules) is the recognised industry code outlining the requirements of electrical distributors when connecting a customer to the distribution systems of New South Wales. The Rules reflect the requirements outlined in the *Electricity Supply Act 1995* and Chapter 5A of the National Electricity Rules. The Division of Resources & Energy, Department of Industry, Skills & Regional Development (DRE) role in the preparation of the Rules is as Convenor and Secretary of the Management Committee and is the notional holder of the copyright of the Rules.

This is the November 2016 revision to the September 2015 edition of the Rules. Two copies of the Rules are available on the DRE website, one has the changes made to the previous revision underlined, a second document is identical except that the underlining of changes is not included. The Management Committee identified in the acknowledgements has endorsed the changes.

The Rules set out the minimum standards for providing safe, reliable and efficient connection services to customer premises.

Neither the Committee nor DRE accepts any responsibility for:

- the design, operation or failure of any electrical installation or installation work; or
- any loss or damage occasioned to any person or property as a result of carrying out connection services.

Compliance with these Rules does not necessarily ensure satisfactory operation of electrical installations or installation work. The contractor is responsible for carrying out any additional work to ensure satisfactory operation.

The Committee comprised representatives of government, electricity distributors, contractors and other stakeholders. It consulted widely through the industry and a range of stakeholders while developing the Rules.

The Committee is responsible for resolving issues, monitoring the impact and further development of the Code of Practice and the Rules. Further editorial amendments will be considered at future meetings of the Committee.

There may be situations the Rules do not cover. These may include unusual connection or situations that have been inadvertently omitted, and alterations to legislation and codes. The management committee does not accept responsibility where these situations occur.

Comments or enquiries on the provisions of these Rules should be directed to the electricity distributor.

David Bellew

Convenor

SERVICE AND INSTALLATION RULES OF NEW SOUTH WALES  
MANAGEMENT COMMITTEE

## Acknowledgements

The following organisations were members of the Committee which prepared the Rules.

Division of Resources & Energy

NSW Department of Industry, Skills & Regional Development

Ausgrid

Endeavour Energy

Essential Energy

Fair Trading

National Electrical & Communications Association

Electrical Contractor and Accredited Service Provider Representative

National Electrical Switchboard Manufacturers Association (NSW)

Aggreko (Generator Industry Specific Advice)

Clean Energy Council (Clean Energy Industry Specific Advice)

Solar Energy Industries Association (Solar Industry Specific Advice)

## Comments and Enquiries

Contact details to make comments and enquiries to Electricity Distributors on these Rules.

### AUSGRID

**Tuggerah:** (02) 4399 8000  
The NSW Central Coast area.

**Hornsby:** (02) 9477 8201  
South of the Hawkesbury River to the North side of Sydney Harbour and the Parramatta River.

**Muswellbrook:** (02) 6542 9017  
Muswellbrook, Scone, Merriwa and Singleton areas.

**Oatley:** (02) 9585 5774  
South of Sydney Harbour and the Parramatta River.

**Wallsend:** (02) 4035 6000  
Cessnock, Lake Macquarie, Newcastle, Maitland and Port Stephens areas.

**ENDEAVOUR ENERGY** 13 37 18  
All areas of Endeavour Energy.

**ESSENTIAL ENERGY** 13 23 91  
All areas of Essential Energy.

---

### Service and Installation Rules of NSW

© State of New South Wales through Division of Resources & Energy, NSW Department of Industry, Skills & Regional Development.

All rights reserved.

November 2016 Edition

ISBN 978 1 74256 553 8

# Contents

<b>1</b>	<b>GENERAL REQUIREMENTS .....</b>	<b>1</b>
1.1	Purpose of these Rules .....	1
1.2	Application .....	1
1.3	Alternative Methods .....	1
1.4	Non compliance .....	2
1.5	Dispute Resolution .....	2
1.6	Safety and Environmental Risk Management .....	2
1.7	NSW Electricity Distributor Areas .....	3
1.7.1	Ausgrid .....	3
1.7.2	Endeavour Energy .....	4
1.7.3	Essential Energy .....	5
1.8	Definitions .....	6
	Accredited Meter Provider .....	6
	Accredited Service Provider .....	6
	Authorisation .....	6
	Connection Device .....	6
	Connection Point .....	6
	Consumers Mains .....	6
	Contractor 6	
	Customer 6	
	Customer Connection Contract .....	6
	Customer Installation .....	6
	Distribution Area .....	6
	Division of Resources & Energy (DRE) .....	6
	Distribution System .....	7
	Electrical Installation .....	7
	Electrically Un-Protected .....	7
	Electricity Distributor (Distributor) .....	7
	Electricity Supply Act .....	7
	High Voltage Installation Responsible Person .....	7
	Metering Equipment .....	7
	Meter Protection Device .....	7
	Metering Provider .....	7
	Non - Urban Classification .....	7
	Overhead Service .....	7
	Point of Attachment (POA) .....	8
	Point of Common Coupling (PCC) .....	8
	Relevant land .....	8
	Repair 8	
	Rules 8	
	Service Equipment .....	8
	Service Fuse .....	8
	Service Protection Device .....	8
	Special Small Service .....	8
	Sydney Trains (ST) .....	8
	Transmission System .....	8
	Underground Service .....	8
	Underground Supply from an Overhead System (UGOH) .....	8
	Urban Classification .....	8
1.9	GENERAL .....	13
1.9.1	Introduction .....	13
1.9.2	Regulatory Provisions .....	13

1.9.3	NSW Fair Trading .....	14
1.9.4	Licensed Electrical Worker Requirements.....	14
1.9.5	Working Live Information for Electrical Workers.....	14
1.9.6	Obligatory Requirements .....	15
1.9.7	Damage .....	15
1.9.8	Damage to other Utilities .....	15
1.9.9	Clearance to other Utilities.....	15
1.10	Electricity Supply .....	16
1.10.1	Supply at 230/400 Volts (low voltage) .....	16
1.10.2	Supply at 230/460 Volts (low voltage) .....	16
1.10.3	Supply at High Voltage .....	16
1.10.4	Supply from the Railway Distribution System .....	16
1.11	Provision for Services, Service and Metering Equipment .....	16
1.11.1	Service Specification.....	16
1.11.2	Advice to Contractors.....	16
1.11.3	Services .....	17
1.11.4	Overhead Service .....	18
1.11.5	Underground Service .....	18
1.11.6	Underground Service Connection to an Overhead Distribution System (UGOH).....	18
1.11.7	Special Small Services .....	18
1.11.8	Special Situations .....	19
1.11.9	Installations on Railway Land .....	19
1.11.10	Service and Metering Equipment.....	19
1.11.11	Alterations, Additions and Upgrades .....	20
1.11.12	Communications .....	20
1.11.13	Accommodation of Electricity Distributor's Substation Equipment.....	20
1.12	Payments for Equipment and Services .....	20
1.12.1	Extension or Alteration of Distribution System .....	20
1.12.2	Contestable Work .....	21
1.12.3	Avoid Premature Expenditure.....	21
1.12.4	Demand Management .....	21
1.13	Accreditation and Authorisation for Level 2 Accredited Service Providers .....	21
1.13.1	Accreditation .....	21
1.13.2	Authorisation .....	22
1.14	Notification of Service Work .....	22
1.15	Connection and Disconnection of Electrical Installations.....	23
1.15.1	Availability of Supply Capacity.....	23
1.15.2	Connection to Supply.....	24
1.15.3	Permanent Disconnection and Removal of Supply .....	24
1.15.4	Safe Installation .....	24
1.15.5	Bush Fire Management.....	24
1.15.6	Inspection.....	25
1.15.7	Disconnection .....	25
1.16	Provision for Customers Installation.....	25
1.16.1	Advice to Customers.....	25
1.16.2	Limits on the Connection and Operation of Equipment.....	25
1.16.3	Balancing of Load .....	27
1.16.4	Protection from Prospective Short Circuit Currents.....	27
1.16.5	Coordination of Protective Devices.....	27
1.16.6	Sealing / Locking.....	27
1.16.7	Earthing.....	27
1.16.8	Installation Switchboards rated above 100A .....	28
1.16.9	Identification .....	28

1.16.10	Termination of Cables.....	28
1.16.11	Power Factor Correction/ Capacitor Installation .....	29
1.16.12	High Voltage Installations .....	29
1.16.13	Private Generation .....	29
1.16.14	Installations on Railway Land .....	29
1.16.15	Identification of Lighting Installations (not owned by a distributor) in Streets, Parks or other Public Areas.....	29
<b>2</b>	<b>UNDERGROUND SERVICES .....</b>	<b>30</b>
2.1	Introduction .....	30
2.1.1	Underground Service .....	30
2.1.2	Underground Service from an Overhead Distribution System .....	30
2.1.3	Specific Railway Requirements .....	30
2.1.4	Non-Distributor Pole Use .....	30
2.2	Service Route .....	30
2.2.1	Special Considerations .....	30
2.2.2	Crossing of Adjoining Property .....	30
2.2.3	Access .....	30
2.3	Underground Consumers Mains.....	31
2.3.1	General .....	31
2.3.2	Electrically Un-Protected Consumers Mains .....	31
2.3.3	Alterations and Additions .....	31
2.3.4	Electrically Protected Consumers Mains .....	31
2.4	Installation of Underground Service .....	31
2.4.1	Installation Requirements .....	31
2.4.2	Searches for Underground Utility Services.....	32
2.4.3	Provision for other Utility Services on Customers Premises .....	32
2.4.4	Position of Underground Service/Consumers Mains.....	32
2.5	Conduit Requirements.....	33
2.5.1	Sizes .....	33
2.5.2	Installing Service Conduits .....	33
2.5.3	Joints.....	33
2.5.4	Draining.....	33
2.6	Cable Requirements.....	37
2.6.1	Cable Specifications .....	37
2.6.2	Maximum Length .....	37
2.6.3	Non-Urban Installations .....	37
2.6.4	Spare Conductors .....	37
2.6.5	Alterations and Additions .....	37
2.7	Connection Point Enclosure - Other than the Main Switchboard.....	38
2.7.1	Enclosure .....	38
2.7.2	Access .....	38
2.7.3	The Termination Enclosure.....	38
2.7.4	Labelling.....	38
2.8	Service Cable Connection Requirements .....	39
2.8.1	Colour Coding .....	39
2.8.2	New Termination Enclosure required in Public Area with existing Distribution System.....	39
2.8.3	Pit and Duct Systems.....	39
2.8.4	Phase selection for the Connection of Services .....	39
2.8.5	Earthing of Equipment .....	39
2.8.6	Phase Selection for Single Phase Controlled Loads, Supplied from a 3 Phase Service .....	39

2.9	Temporary Support in a Permanent Position for Building Purposes.....	41
2.10	Underground Supply from an Overhead Distribution System (UGOH).....	42
2.10.1	UGOH .....	42
2.10.2	Installation on the Electricity Distributor's Pole for an Underground Service with conductors up to a maximum 70mm <sup>2</sup> .....	42
2.10.3	Installation on the Electricity Distributor's Pole for an Underground Service with conductors larger than 70mm <sup>2</sup> .....	42
2.10.4	Maximum Number and Location of Underground Services that can be installed on an Electricity Distributor's Pole.....	42
2.10.5	Underground Supply from Overhead Reticulation.....	43
<b>3</b>	<b>OVERHEAD SERVICES .....</b>	<b>47</b>
3.1	Introduction .....	47
3.1.1	Approval for an Overhead Service.....	47
3.1.2	Alternative to an Overhead Service .....	47
3.1.3	Distributor's Street Poles .....	47
3.1.4	Specific Railway Requirements .....	47
3.1.5	Existing Service – Alterations and Additions .....	47
3.1.6	Retaining an Existing Service .....	47
3.1.7	Non-Distributor Pole Use .....	47
3.2	Service Route and Point of Attachment .....	48
3.2.1	Special Overhead Considerations .....	48
3.2.2	Service Route, Point of Attachment and Phase Selection.....	48
3.2.3	Phase Selection for Single Phase Controlled Loads, supplied from a 3 Phase Service .....	49
3.2.4	Crossing of Adjoining Property .....	49
3.2.5	Crossing of Swimming Pool Zones.....	49
3.2.6	Details of Service Route .....	49
3.3	Aerial Consumers Mains .....	50
3.3.1	Electrically Un-Protected Consumer Mains .....	50
3.3.2	Electrically Protected Consumers Mains .....	50
3.3.3	Maintenance .....	50
3.4	Cable Requirements.....	50
3.4.1	Minimum Requirements.....	50
3.4.2	Existing Overhead Service Cable Ratings.....	50
3.5	Spans, Tensions and Clearances.....	51
3.5.1	Maximum Span .....	51
3.5.2	Tensions .....	51
3.5.3	Clearances from Structures, Vegetation and Ground.....	51
3.6	Access to Service and Point of Attachment .....	55
3.7	Facilities to be Provided by the Customer.....	55
3.7.1	Point of Attachment.....	55
3.7.2	Private Post/Pole .....	57
3.7.3	Attachments to Buildings or Structures.....	58
3.7.4	Protection against Corrosion .....	60
3.7.5	Earthing Metallic Supports.....	60
3.7.6	Strength Requirements of Attachments and Supports .....	60
3.8	Builders Service.....	62
3.8.1	Split-Posts.....	62
3.8.2	Consumers Mains .....	62
3.9	Underground Supply from Overhead Distribution System (UGOH).....	62



3.10	Minimum Sizes of Posts, Poles and Struts for Overhead Services .....	64
<b>4</b>	<b>SERVICE AND METERING EQUIPMENT .....</b>	<b>73</b>
4.1	Introduction .....	73
4.1.1	Existing Installations .....	73
4.2	Location and Accessibility of Service and Metering Equipment.....	73
4.2.1	Single Domestic Premises .....	74
4.2.2	Single Business Premises .....	75
4.2.3	Multiple Occupancy Premises .....	75
4.3	Unsuitable Locations .....	76
4.4	Hazards of Existing Meter and Switchboard Panels that may Contain Asbestos .....	76
4.5	Facilities for the Installation of Meter and Service Equipment .....	77
4.5.1	Service and Metering Equipment Panel .....	77
4.5.2	Service and Metering Equipment Enclosure.....	77
4.5.3	Free length of consumers mains/underground service .....	77
4.5.4	Physical Protection of Service and Metering Equipment.....	77
4.5.5	Isolated and Unattended Locations .....	77
4.5.6	Top Hinged Switchboard Doors .....	77
4.5.7	Glazed Switchboard Doors .....	77
4.5.8	Fixing of Service Equipment Enclosure .....	77
4.5.9	Fixing of the Service and Metering Equipment.....	77
4.6	Locking of Service and Metering Enclosures .....	78
4.7	Service Protection and Metering Protection Devices .....	78
4.7.1	Selection of fuse carrier and base ratings for fuses as Service Protection Devices and Meter Protection Devices .....	78
4.7.2	Selection of Fuse Element Rating for Service Protection Devices and Meter Protection Devices.....	78
4.7.3	Service Protection Device and Meter Protection Device combined .....	78
4.7.4	Location of Service Protection Devices and Meter Protection Devices .....	78
4.7.5	100A Fuses as Service Protection Devices and or Meter Protection Devices .....	80
4.7.6	Enclosures for Service Protection Device greater than 100A.....	81
4.7.7	Service Protection Devices greater than 100A.....	81
4.7.8	Circuit Breakers in Lieu of 100A Service Protection Fuse.....	81
4.7.9	Circuit Breakers in Lieu of Service Protective Devices greater than 100A .....	81
4.7.10	Connection to Service Protection Devices.....	82
4.7.11	Identification .....	82
4.8	Rewirable Fuses .....	82
4.9	Service Active Link .....	82
4.10	Service and Metering Neutral Links .....	83
4.10.1	Service Neutral Link.....	83
4.10.2	Meter Neutral Link.....	83
4.11	Low Voltage Installations up to 100A per Active Conductor - Whole Current Metering .....	83
4.11.1	Whole Current Metering.....	83
4.11.2	Bottom Connected Meters .....	84
4.11.3	Load Control Equipment .....	85
4.12	Connections at Service and Metering Equipment .....	86
4.12.1	Cable Preparation and Termination.....	86
4.12.2	Maximum Conductor Sizes for Services Rated to 100A.....	87

4.12.3	Flexible Switchboard and Panel Wiring .....	87
4.13	Provision of Isolation of Customer Installations.....	87
4.13.1	Whole Current Metering.....	87
4.13.2	Current Transformer Metering .....	87
4.14	Multiple Installations .....	89
4.14.1	Meter Protection Device.....	89
4.14.2	Arrangement of Metering Neutrals.....	89
4.14.3	Paralleling Links.....	89
4.14.4	Mounting Provisions for Meters .....	89
4.14.5	Unmetered Submains .....	89
4.14.6	Labelling.....	89
4.14.7	Metering Equipment Requirements .....	89
4.15	Spacing Between Metering Equipment and High Current Conductors .....	91
4.15.1	Multicore and Bunched Single Core Cables .....	91
4.15.2	Spaced Single Core Cables, Busway or Busbars .....	91
4.15.3	Shielding .....	91
4.15.4	Special Cases .....	91
4.16	Sealing of Service and Metering Equipment .....	92
4.16.1	Multiple, Single and Large Installations .....	92
4.17	LV Current Transformer Metering.....	93
4.17.1	Submission of Design .....	93
4.17.2	Prospective Short Circuit Current .....	93
4.17.3	Protection Grading .....	93
4.17.4	Whole Current Metering.....	93
4.17.5	Current Transformer Facilities .....	94
4.17.6	CT Enclosure - Construction.....	95
4.17.7	Vermin Proofing .....	95
4.17.8	Doors and Access Cover .....	95
4.17.9	Identification of Enclosures.....	95
4.17.10	CT Security Locking or Sealing .....	95
4.17.11	CT Location and Access .....	95
4.17.12	Voltage Circuit Protection .....	95
4.17.13	Current Transformers.....	96
4.17.14	Mounting of Current Transformers.....	99
4.17.15	Primary Conductors .....	99
4.17.16	Cubicle Switchboard enclosed Current Transformers.....	99
4.17.17	Connection of Neutral Links.....	99
4.17.18	Earthing.....	100
4.17.19	Stand-by Supply Equipment .....	100
4.18	Meter Panel Location and Access for CT Metering.....	101
4.18.1	CT Meter Panel.....	101
4.19	Facilities for Connection of CT Metering Equipment.....	101
4.19.1	Protective Enclosure .....	101
4.19.2	Current Circuit Wiring.....	103
4.19.3	Voltage Circuit Wiring .....	103
4.19.4	Meter Test Block .....	103
4.19.5	Summation Equipment Wiring .....	104
4.19.6	Load Control Device and Contactor Wiring .....	104
4.19.7	Earthing of Meter Surround .....	104
4.19.8	Supply for National Electricity Rule Compliant Communications Equipment.....	104
4.20	Controlled Load for CT Metering .....	104
4.21	Labelling .....	106
4.21.1	Guide to Labelling Electrical Equipment on Switchboards ....	106
4.21.2	Examples and Explanations of Labelling.....	107

<b>5</b>	<b>SPECIAL SMALL SERVICES.....</b>	<b>109</b>
5.1	Introduction.....	109
5.2	Connection to the Distribution System.....	109
5.2.1	Underground Supply from Overhead Mains.....	109
5.2.2	Underground Supply from Underground Mains.....	109
5.2.3	Overhead Service to Customer's Structure.....	110
5.3	Customer's Structure.....	110
5.4	Concrete and Steel Poles.....	110
5.5	Electrical Installation.....	110
5.5.1	Type of Installation.....	110
5.5.2	Connection Point Termination Box.....	110
5.5.3	Control and Protection.....	110
5.5.4	Installation on the Electricity Distributor's Pole.....	111
5.5.5	Earthing.....	111
5.5.6	Labelling.....	111
5.5.7	Underground Sub Mains.....	111
<b>6</b>	<b>CAPACITOR INSTALLATIONS.....</b>	<b>118</b>
6.1	Introduction.....	118
6.1.1	Minimum Power Factor.....	118
6.1.2	What is Power Factor.....	118
6.1.3	Expressing Power Factor.....	118
6.1.4	Why Power Factor is Important to your Business.....	118
6.1.5	Power Factor Correction.....	118
6.1.6	Cost Savings.....	119
6.2	Equipment Requirements.....	120
6.2.1	Capacitor Switching Steps.....	120
6.2.2	Equipment Design.....	120
6.2.3	Fluorescent Lighting Installations.....	120
6.3	Existing Installations.....	123
6.3.1	Power Factor Problems in Non-Domestic Multi-Tenanted and Large Installations.....	123
6.4	Ripple Control and Harmonic Blocking.....	123
6.4.1	Blocking System.....	124
6.4.2	System Harmonic Blocking.....	124
6.4.3	Low Frequency Ripple Systems.....	124
6.4.4	Ripple Control Blocking.....	124
6.5	Labelling.....	125
6.6	Blocker Circuits.....	125
6.6.1	Series Resonant Frequency.....	125
6.7	Rejecter Circuits.....	126
6.7.1	Signal Frequency Impedance.....	126
6.7.2	Series Resonant Frequency.....	126
6.8	Stopper Circuits.....	127
6.8.1	Signal Frequency Impedance.....	127
6.8.2	Series Resonant Frequency.....	127
6.9	Power Factor Correction Equipment Installation.....	127
6.9.1	Electrical and Mechanical Protection of Supply Conductors.....	128
6.9.2	Isolation of Equipment.....	128
6.9.3	Clearances around Equipment.....	128
6.9.4	Frequency Rejection Equipment.....	128
6.9.5	Oil Filled Capacitors.....	128
6.9.6	Labelling of Equipment.....	128
6.9.7	Power Factor Monitoring.....	128
6.9.8	The Power Factor Controller.....	128

<b>7</b>	<b>HIGH VOLTAGE CUSTOMER INSTALLATIONS.....</b>	<b>129</b>
7.1	Introduction .....	129
7.2	General Information.....	129
7.3	Submission of Proposal.....	129
7.4	Provision of Facilities for Metering Equipment .....	130
7.5	Customer's High Voltage Installation .....	130
7.5.1	Connection Point.....	130
7.5.2	Compliance .....	130
7.5.3	Supply Voltage.....	130
7.5.4	Fault Levels.....	130
7.5.5	Consumers Mains .....	131
7.5.6	Bush Fire Precautions.....	131
7.5.7	Protection and Control of Incoming Supplies .....	131
7.5.8	Testing and Inspection.....	131
7.5.9	Operation of the Customer's High Voltage Installation.....	131
7.5.10	Maintenance .....	131
7.5.11	Power Factor Correction .....	131
<b>8</b>	<b>ALTERNATIVE SOURCES OF SUPPLY .....</b>	<b>134</b>
8.1	Introduction .....	134
8.2	Costs.....	134
8.3	Stand-By Generating Plant - General.....	134
8.3.1	Conditions of Use.....	134
8.3.2	Spacing for Conductors .....	135
8.3.3	Changeover Equipment for Non-Parallel Operation .....	135
8.3.4	Switching the Neutral .....	136
8.3.5	Multiple Generators.....	136
8.4	Requirements for Stand-By Generator Synchronise Close Transfer Trip .....	137
8.4.1	SCTT Operating Procedure .....	137
8.4.2	Additional Protection .....	137
8.5	Requirements for Generator Parallel Operation.....	138
8.5.1	Operating Procedure.....	138
8.5.2	Additional Protection .....	138
8.6	Small Scale Parallel Customer Generation (via Inverters).....	139
8.6.1	Introduction .....	139
8.6.2	Responsibilities .....	139
8.6.3	Export limiting Systems.....	139
8.6.4	Approvals Documentation.....	139
8.6.5	Metering Requirements.....	140
8.6.6	Construction Permits.....	140
8.6.7	Islanding.....	140
8.6.8	Multi-Phase Generating Systems .....	140
8.6.9	Power Factor Setting .....	140
8.6.10	DC Isolation .....	140
8.6.11	Generator Connection Arrangement.....	141
8.6.12	Switching Requirements .....	141
8.6.13	Conductor Size Requirements .....	141
8.6.14	Islanding Protection Equipment .....	141
8.6.15	Reconnection Procedure .....	142
8.6.16	Generator Supply Main Switch .....	142
8.6.17	Shut Down Procedure.....	142
8.6.18	Storage Systems.....	142
8.7	Labelling .....	145

## Amendment Status Schedule

Amendment Number	Date Issued	Sections Affected
1	June 2015	All
2	September 2015	Minor Edit to Figure 1.2
3	July 2016	Major amendments to Sections 1 and 4 as well as minor amendments to other sections of the document to support the NSW Electricity (Advanced Metering) Bill 2016
3a	September 2016	Clause 4.7.5 noted AS60269.3.0 & AS60269.3.1 withdrawn
<b><u>3b</u></b>	<b><u>November 2016</u></b>	<p><b><u>Clause 4.7.2 and Notes to Table 4.1 amended to clarify rating of MPD fuse and use of CB in lieu of fuse</u></b></p> <p><b><u>Clause numbering in subclauses 1.11.1.1 – 1.11.1.4 corrected</u></b></p> <p><b><u>Clause reference under Meter Protection Device definition amended to 4.7</u></b></p>

**Notes:**

1. The Management Committee, may, at intervals of not more frequently than six months from the date of publication, make amendments to these Rules, including this Amendment Status Schedule.
2. The Management Committee may publish amendments to these Rules on the Division of Resources & Energy, Department of Industry, Skills & Regional Development website.  
<http://www.resourcesandenergy.nsw.gov.au/energy-supply-industry/pipelines-electricity-gas-networks/network-connections/rules>
3. The user of these Rules is responsible for ensuring that this Amendment Status Schedule and the relevant Sections are maintained up to date. No liability is accepted for errors or events arising from a failure or omission to update these Rules.



# 1 GENERAL REQUIREMENTS

## 1.1 Purpose of these Rules

Electricity distributors are obliged to connect customers to their distribution system under a customer connection contract. The contract stipulates terms and conditions that must be satisfied by the electricity distributor and the customer.

To ensure that the electrical installation of a customer can be connected to the distribution system, the electricity distributor can describe the requirements of the connection to its system (Service Rules) and compatible requirements of the electrical installation (Installation Rules).

These Rules provide uniform requirements for electricity distributors, metering providers, accredited service providers, contractors and customers throughout NSW. This has been achieved by:

- (a) Providing consistent requirements from electricity distributors.
- (b) Specifying electrical installation requirements as permitted by AS/NZS 3000.
- (c) Specifying service requirements to promote industry standardisation of equipment.
- (d) Specifying service requirements which comply with the provisions of the Electricity Supply Act.
- (e) Including recommendations and advisory information which may indicate future requirements of AS/NZS 3000 and legislation.
- (f) Providing information to the electricity supply industry, metering providers accredited service providers and the electrical contracting industry which enables them to work together to promote standardisation of systems and equipment.

## 1.2 Application

Electricity distributors have adopted these Rules through their customer connection contracts.

Where the word “must” appears, it indicates that the electricity distributor cannot negotiate with the customer on that particular matter.

Where other less definite terminology is used, a degree of flexibility is indicated and it may be feasible for the customer to negotiate with the electricity distributor. Where possible, the customer’s wishes will be taken into account.

These Rules are designed to achieve safe, reliable and efficient outcomes for both the electricity distributor and customer.

Consideration of safety to customers, electricity workers and the general public are paramount - as well as considerations of potential liability.

Should a contravention of these Rules (without an accepted alternative method) occur, the electricity distributor is entitled to refuse, suspend or discontinue supply, or require correction of the contravention subject to any resolution achieved by a dispute resolution process.

The Rules are presented in two parts:

- (a) Section 1 provides the fundamental legislative obligations, definitions, policy, conditions and informative statements.
- (b) Sections 2 to 8 contain detailed design, material and construction information for services, service equipment and metering equipment. These serve to clarify the electricity distributor requirements and any alternatives, to accredited service providers, contractors and installation designers.

For the avoidance of doubt, nothing in the Rules is intended to prevent or impede an electricity distributor exercising their rights under legislation in the management of their distribution system and equipment. The distributor for example, may repair, maintain, augment or renew service mains without reference to the rules as it would be managing its system in accordance with jurisdictional regulatory requirements.

## 1.3 Alternative Methods

Note that alternatives to metering requirements are excluded from this clause, any alternatives would need to be addressed with the relevant metering provider.

Where the customer proposes an alternative method that is not specifically contained in these Rules, the proposal must deliver the same or better level of safety, reliability and efficiency.

The electricity distributor must deal with proposals for alternative methods using the following procedure:

- (a) Applications for alternative methods must be made in writing to the relevant electricity distributor.
- (b) The electricity distributor must acknowledge receipt of the application in writing, within two weeks.
- (c) The proposal must be given due consideration and a formal response provided in writing, within 10 business days (or as otherwise advised). The electricity distributor must outline the reasons for its decision.
- (d) Appeals (where necessary) should be made to the electricity distributor in writing. The electricity distributor must review its decision and provide a written response, within one month (or as otherwise advised).
- (e) Further appeals (where necessary), should be made in writing to the Division of Resources & Energy for assistance.

Acceptance of any proposed alternative method does not imply automatic recognition as an industry standard.

#### **1.4 Non compliance**

Where the customer does not comply with these Rules or an accepted alternative method the electricity distributor may:

- i) Refuse, suspend or discontinue supply, or
- ii) Require the customer to rectify the service work or comply with the conditions of connection of supply.

The electricity distributor may require the customer to pay for a re-inspection of the work in accordance with the Australian Energy Regulator pricing determinations.

#### **1.5 Dispute Resolution**

If the electricity distributor and a customer are unable to resolve a dispute on matters related to these Rules using the electricity distributor's dispute resolution procedure, provided for in the customer connection contract, the customer may seek to have the matter resolved by the Energy and Water Ombudsman NSW (EWON) or by another process in accordance with the terms of the contract.

#### **1.6 Safety and Environmental Risk Management**

These Rules specify the technical requirements for service and metering work associated with electrical installations. Electrical contractors, metering providers and accredited service providers trained and qualified to carry out this work must do so in accordance with the conditions of their electrical contractor's license, accreditation and authorisation as applicable. They must abide by all applicable safety and environmental legislative requirements. This includes a requirement to assess the safety and environmental risks associated with the carrying out of work and taking appropriate action to mitigate those risks. The general process is summarised as follows:

- (a) Identify hazards associated with the work and the worksite.
- (b) Assess the risks associated with the identified hazards.
- (c) Implement appropriate control measures to mitigate the hazards.

An example of this process is the use of a Hazard Assessment Checklist (HAC) at the work site prior to commencing work. The HAC includes a check of tools and equipment and worksite safety and environmental hazards.

**Refer to AS/NZS 4836 'Safe Working on Low Voltage Installations' as a guide.**



## 1.7 NSW Electricity Distributor Areas

### 1.7.1 Ausgrid

24 Hour emergency  
General enquiries  
Street lighting

13 13 88  
13 15 25  
1800 044 808



1.7.2 Endeavour Energy

General enquiries 13 37 18  
Emergencies 13 10 03



1.7.3 Essential Energy

General enquiries	13 23 91
Electricity supply interruptions	13 20 80



## 1.8 Definitions

Meanings for the words used in these Rules are listed below. Refer also to figures provided.

### **Accredited Metering Provider**

See Metering Provider

### **Accredited Service Provider**

Means a person accredited to provide customer connection services in accordance with the Electricity Supply Act & Regulations.

### **Authorisation**

Permission granted to an individual in writing by an electricity distributor to work on or near an electricity distributor's distribution system.

### **Connection Device**

Means a fixture that forms the physical junction through which electricity is transmitted across a break in electrical conductors. Where the connection device forms part of the electrical installation as defined in Connection Point subclause (a), it is owned and maintained by the customer for connection to the Distribution System.

### **Connection Point**

The definition of Connection Point in these Rules fulfils the requirements of defining the Connection Point in the Electricity Supply Act..

Means the junction where the Distribution System is connected (by means of a Connection Device) to the Customers Installation.

The Connection Point as defined in subclauses (a) and (b) must be situated on relevant land.

The following situations describe the different types of connections at the Connection Point and also reference the relevant diagrams within these Rules:

- (a) Where electricity is supplied from the Distribution System (that is not from a substation on relevant land) the connection point is on the distribution system side of the connection device closest to the distribution system. Refer to Figures 1.1 (a), (b), (c) and (d) and 1.2 (a), (b), (c) and (d).
- (b) Where the electricity is supplied from a distribution substation on relevant land, the connection point is at the electrical installation side of connection device situated at the substation. Refer to Fig 1.1 (e) and 1.2 (e).
- (c) The connection point for a HV customer, a special small service or a customer who has entered into a relevant agreement with the electricity distributor concerned, is the Connection Point agreed in writing between the customer and the electricity distributor.
- (d) For Rail network electricity systems not covered by (c) in this definition, the

Connection Point with the Railway Direct Current (DC) traction system is at the DC terminals of the rectifier in the railway traction substation.

For the purposes of applying this definition to electrical installations that were commissioned prior to the current version of the rules, it is possible for a Connection Point to be notional. *For example, using an historic installation that is typically described in figure 1.1(d), this clause determines that the connection point is at the join in the pillar inside the boundary line. However, if historically this situation has existed without a physical connection to make and break conductors at the required location (ie contrary to current requirements, a continuous piece of wire enters and exits the pillar in this example), a notional connection point exists at this point as described in figure 1.1(d).*

### **Consumers Mains**

Consumers mains are the conductors between the Connection Point and the main switchboard and form part of an electrical installation. Consumers Mains may be overhead, underground or within a structure. Refer Figures 1.1(b, c, d, e) and 1.2 (b, c, d, e).

### **Contractor**

Means a licenced electrical contractor who carries out installation work or electrical tests on an electrical installation.

### **Customer**

A Customer is an individual or entity who (either personally or through an agent) applies for or receives or makes use of a connection of an Electrical Installation to the electricity distributor's distribution system..

### **Customer Connection Contract**

Is a contract between the network operator and a customer that contains the terms and conditions under which an Electrical Installation of a customer is connected to the electricity distributor's distribution system.

### **Customer Installation**

Means an electrical installation

### **Distribution Area**

Distribution area in relation to the electricity distributor means the distribution districts described in clause 83 and listed in schedule 3 of the Electricity Supply Act.

### **Division of Resources & Energy (DRE)**

Means the Division of Resources & Energy of the NSW Department of Industry, Skills & Regional Development responsible for the preparation and publication of the Rules.

### **Distribution System**

Means the electricity power lines, associated equipment and electricity structures that are used to convey and control the conveyance of electricity to or from the premises of customers or generators; or to, from and along the rail network electricity system. A distribution system does not include a transmission network.

The distribution system does not include any conduit, pole or other structure supporting protecting or enclosing electricity lines where those assets are part of an Electrical Installation

### **Electrical Installation**

Means as defined by the *Electricity (Consumer Safety) Act 2004*: any fixed appliances, wires, fittings, meters, apparatus or other electrical equipment used for (or purposes incidental to) the conveyance, measuring, control and use of electricity in a particular place, but does not include any of the following:

- (a) Any electrical equipment (other than a meter) used, or intended for use, in the generation, transmission or distribution of electricity that is:
  - (i) Owned or used by an electricity supply authority, or
  - (ii) Located in a place that is owned or occupied by such an authority.
- (b) Any electrical article connected to, and extending or situated beyond, any electrical outlet socket.
- (c) Any electrical equipment in or about a mine.
- (d) Any electrical equipment operating at not more than 50 volts alternating current or 120 volts ripple-free direct current.
- (e) Any other electrical equipment, or class of electrical equipment, prescribed by the regulations.

An Electrical Installation may supply multiple customers, including for example:

- (a) Strata title developments
- (b) Embedded networks
- (c) Shopping centres
- (d) Buildings with separately metered sub letting arrangements
- (e) Previous arrangements of subtractive metering

Note: Private metering arrangements cannot form separate customers without formal arrangements compliant with the National Electricity Market. Any circumstances that fall into this category are treated as a single customer by the NEM, and in any case are treated as the one Electrical Installation for the purposes of these rules.

### **Electrically Un-Protected**

Means where the conductors [Consumer's mains] from the connection point are not protected by customers protection and are only protected by distribution protection equipment.

### **Electricity Distributor (Distributor)**

Means the electricity distributor (distributor) within whose distribution area any Electrical Installation or installation work is situated or where the installation work is carried out.

Note: Sydney Trains is the distributor for electrical installations on railway land and for a limited number of customers supplied from the rail network.

### **Electricity Supply Act**

means the Electricity Supply Act 1995 No.94 (NSW) .

### **High Voltage Installation Responsible Person**

The owner, controller or operator of a high voltage (HV) installation ie taking supply at voltages higher than 1,000V AC.

### **Metering Equipment**

Equipment used to measure the electricity consumption at a metering installation as defined by the National Electricity rules. This does not include load control equipment.

### **Meter Protection Device**

A fuse (which complies with Clause 4.7,) or other protection and isolation device located on the un-metered side of the installation, intended for the isolation and protection of whole-current metering and the associated customer installation.

For single customer services up to 100 Amp, the service protection and meter protection devices can be the one physical device.

A fuse performing the role of a Meter Protection Device must have a base and carrier capable of carrying 100Amps minimum, but the fuse cartridge is to be 80Amps unless directed by the metering provider to install a different size.

### **Metering Provider**

An entity registered by AEMO under the National Electricity Rules to install metering equipment.

### **Non - Urban Classification**

Means areas classified as not urban.

### **Overhead Service**

Means overhead or aerial conductors, operating at not more than 600/1000V, between the electricity distribution system and the connection point. Refer to Figure 1.1.

The overhead service comes under the ownership, control and maintenance of the electricity distributor as part of its network. The

overhead service includes the strain clamp at the Point of Attachment but does not include the bracket or other form of anchor at which the overhead service is terminated or the connection device.

### **Point of Attachment (POA)**

Means the point or points, at which the mechanical loads of overhead conductors of an overhead service or overhead consumer's mains are terminated on a customer's building, pole or structure. Refer to Figures 1.1 (b, c, e), 1.2 (c).

The POA forms part of an electrical installation.

### **Point of Common Coupling (PCC)**

The point on a distribution system, electrically nearest to a particular customer or installation, at which other customers or installations are, or could be, connected. Refer to Figures 1.1, 1.2, 2.5 and 2.8.

The electrical assets on the installation side of the Point of Common Coupling are dedicated for the use of that electrical installation. (It is possible for the point of common coupling to be within a High Voltage system).

### **Relevant land**

Means land to which the customer concerned or the electrical installation owner has a legal right of access for the purpose of constructing or maintaining the electrical installation.

### **Repair**

Means restoration to an acceptable operating or usable condition, a broken, damaged or failed device or item of equipment or part thereof. eg 'like for like' replacement.

### **Rules**

**Rules** means the Service and Installation Rules of New South Wales as amended from time to time.

### **Service Equipment**

Means the distributor's equipment associated with the supply, control and non-revenue metering of electricity to a customer. It includes associated equipment that may or may not be provided by the distributor to meter and control (e.g. meters, current & voltage transformers, communication equipment and wiring), to protect (eg service protection fuses), support (eg brackets), connect (eg neutral links, service connection boxes) and secure (eg security seals) the service, meters and control devices.

### **Service Fuse**

Service Fuse is taken to generally refer to a Service Protection Device (*This definition is obsolete but is retained to allow references from external documents to exist without ambiguity.*)

### **Service Protection Device**

The first protection device which complies with Clause 4.7, located on the installation side or forming part of the Connection Point.

### **Special Small Service**

Means supplies located in public places, un-metered and of LV single phase up to 10 Amps rating where an accurate assessment of energy usage can be made.

### **Sydney Trains (ST)**

Sydney Trains is the electricity distributor for electrical installations on railway land within the railway 1500V dc electrified track area. It is also used to describe any other rail network that exists and is not specifically defined in these rules.

### **Transmission System**

Means any electricity power lines and associated equipment and electricity structures that are a transmission system operating at 220kV and above, plus:

Parts of networks operating between 66kV and 220kV paralleling and supporting the transmission network (where deemed by the Australian Energy Regulator) to be a transmission network.

### **Underground Service**

Means underground cables, operating at a voltage not exceeding 600/1000 volts, between the electricity distribution system and the Connection Point. Refer to Figure 1.2.

The underground service comes under the ownership, control and maintenance of the electricity distributor as part of its network. The underground service does not include the conduit, structure or enclosure protecting or enclosing the cable that is situated on relevant land.

### **Underground Supply from an Overhead System (UGOH)**

Underground supply from an overhead distribution system (UGOH) is a term used where a customer is supplied by an underground service from an overhead distribution system.

### **Urban Classification**

Means areas where the majority of land is zoned for residential and / or commercial and / or industrial use within a town or city type of area which is contiguous with other similar town or city areas with an aggregated population of at least 5,000 people.

**Figure 1.1: Definitions – Supply from Overhead Distribution Mains**

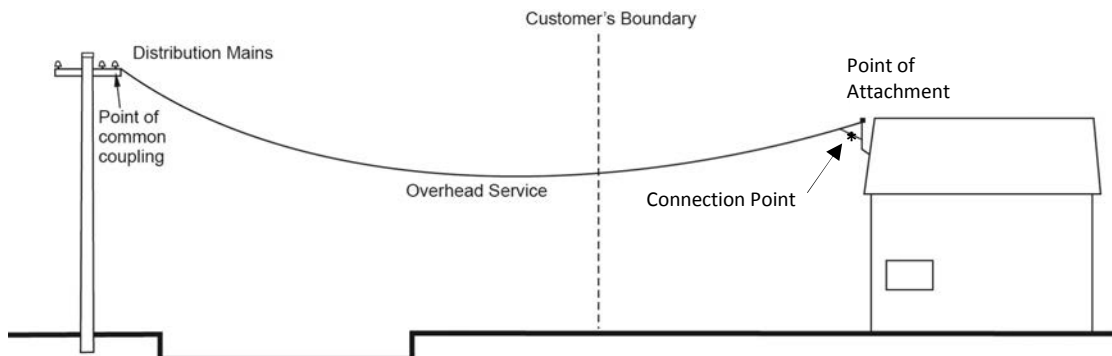

**(a) Overhead Service**

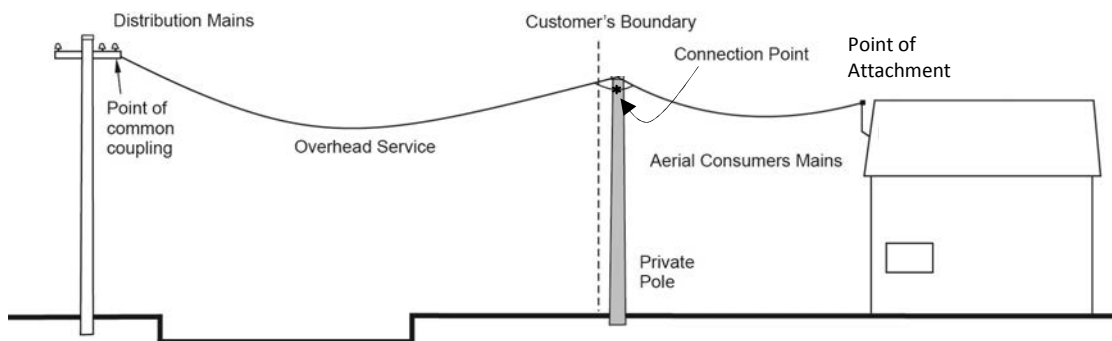

**(b) Overhead Service and Aerial Consumers Mains**

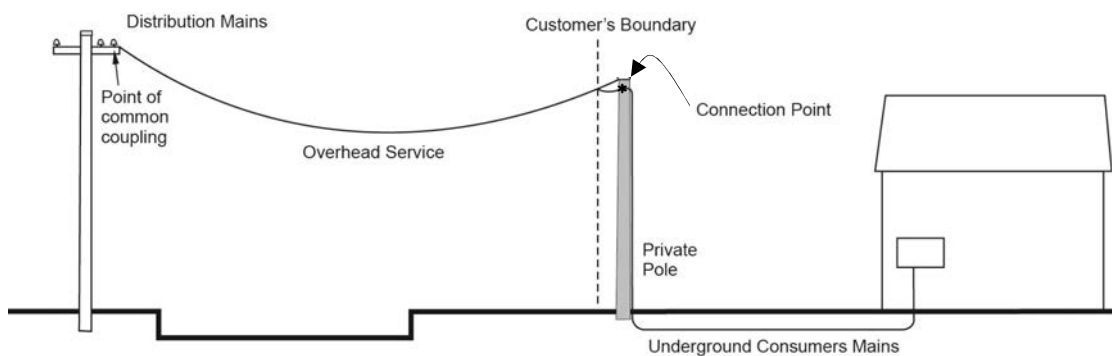

**(c) Overhead Service and Underground Consumers Mains**

**Figure 1.1 (continued): Definitions – Supply from Overhead Distribution Mains**

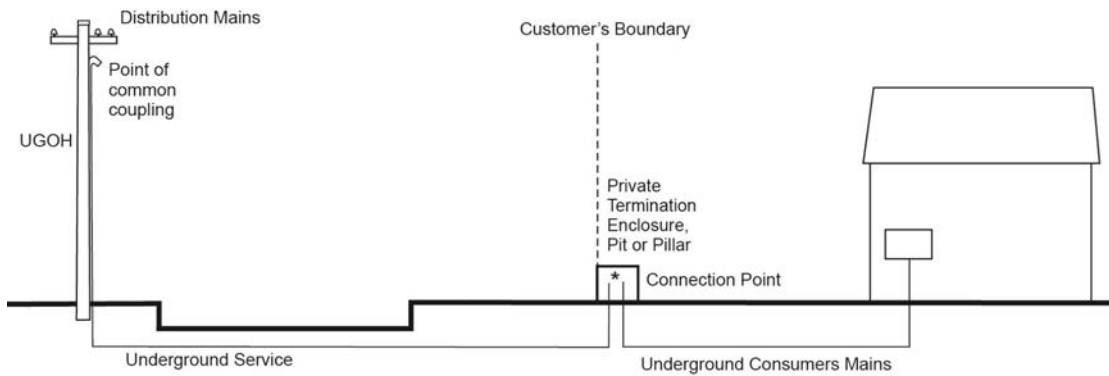

**(d) Underground Service and Consumers Mains from overhead mains on electricity distributor's pole**

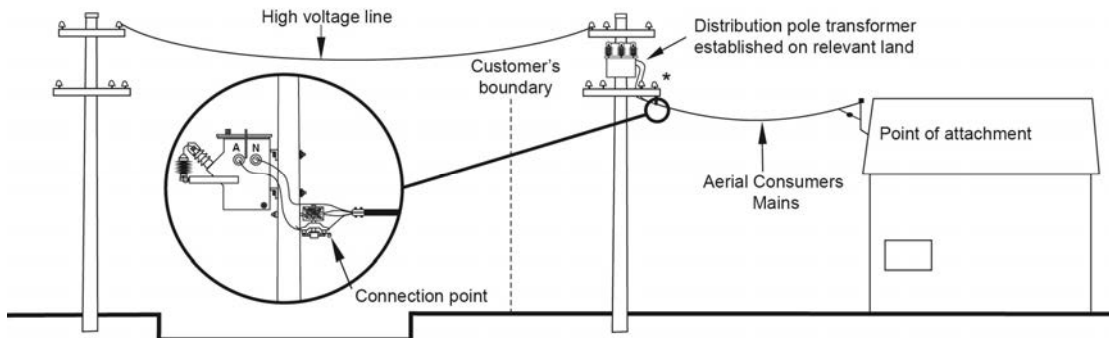

**(e) Overhead Service from substation on relevant land**

Note that in this case, the Point of Common Coupling could be the:

- Connection point – if other future LV customer connections are likely, or,
- The High Voltage Connections for the High Voltage Tee line if assets are totally dedicated to the one installation, or,
- Any other point between the two options above depending on possible additional installation arrangements.



**Figure 1.2: Definitions – Supply from Underground Distribution Mains**

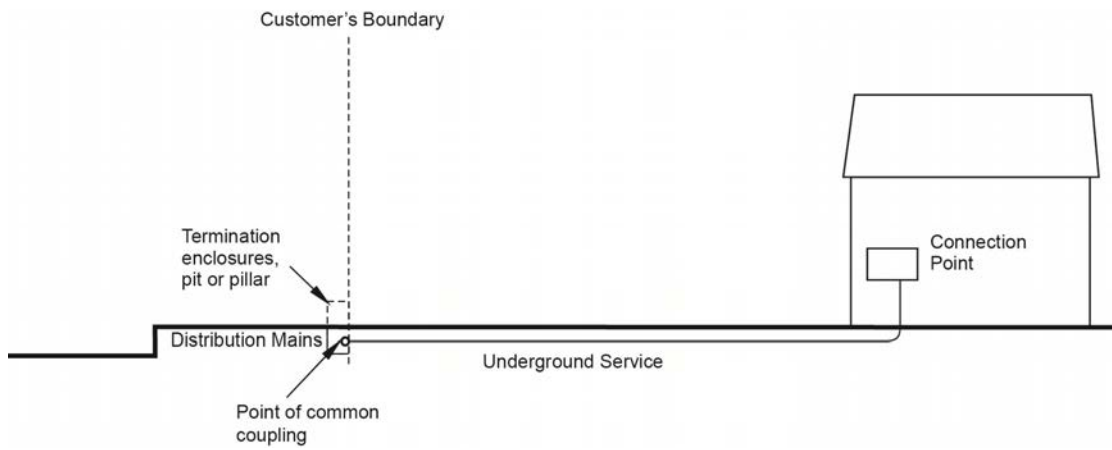

**(a) Underground Service**

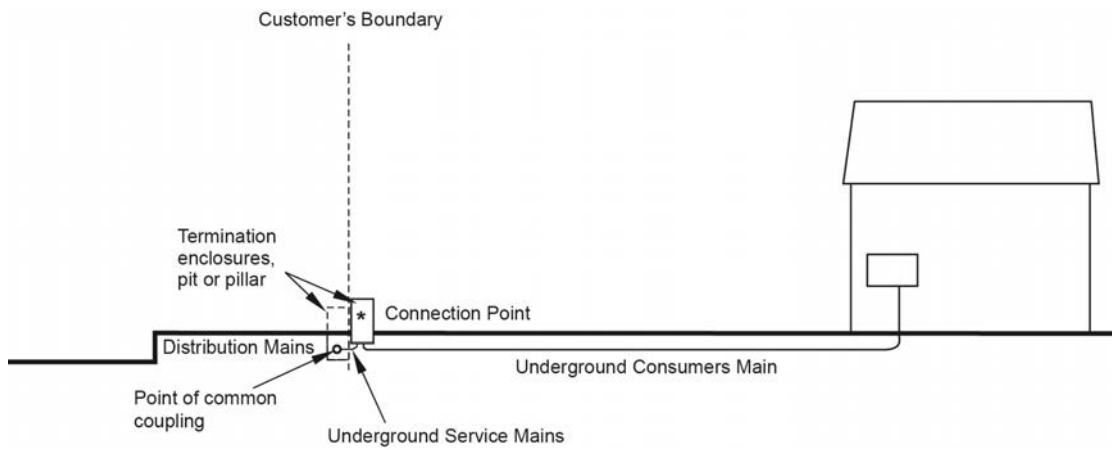

**(b) Underground Service and Underground Consumers Mains**

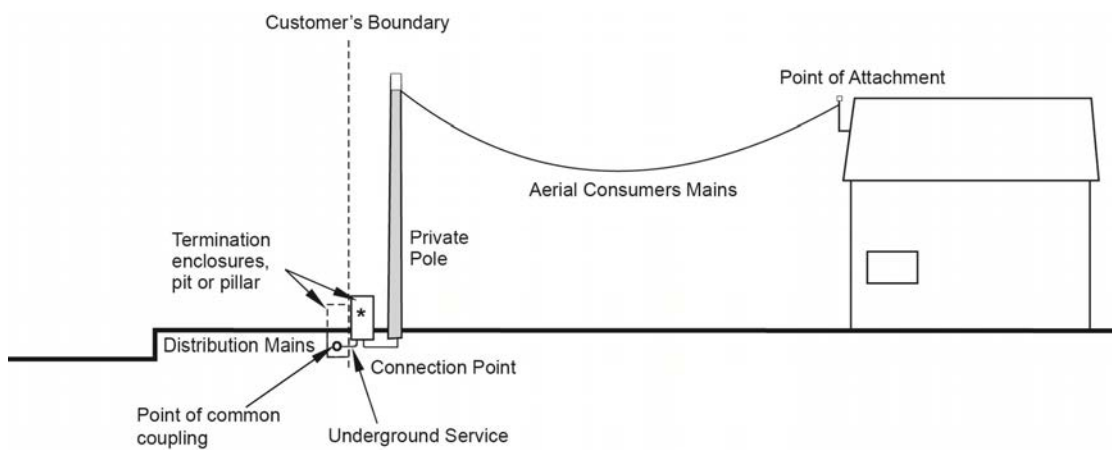

**(c) Underground Service and Aerial Consumers Mains**

**Figure 1.2 (continued): Definitions – Supply from Underground Distribution Mains**

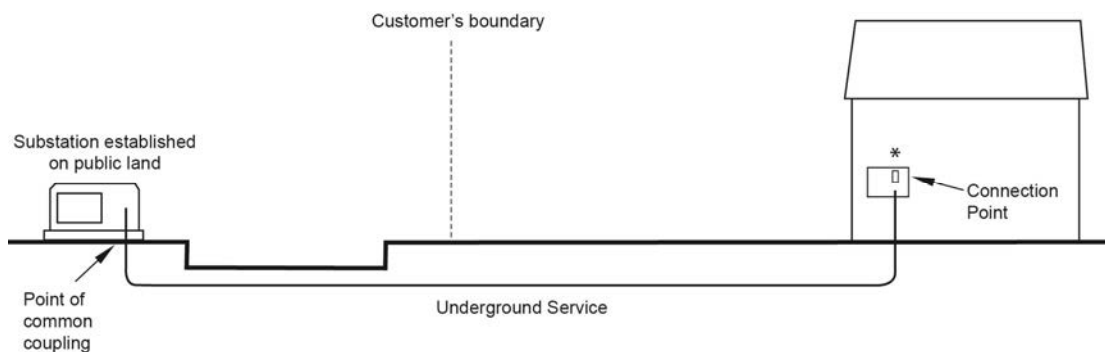

**(d) Underground Services from Substation on public land**

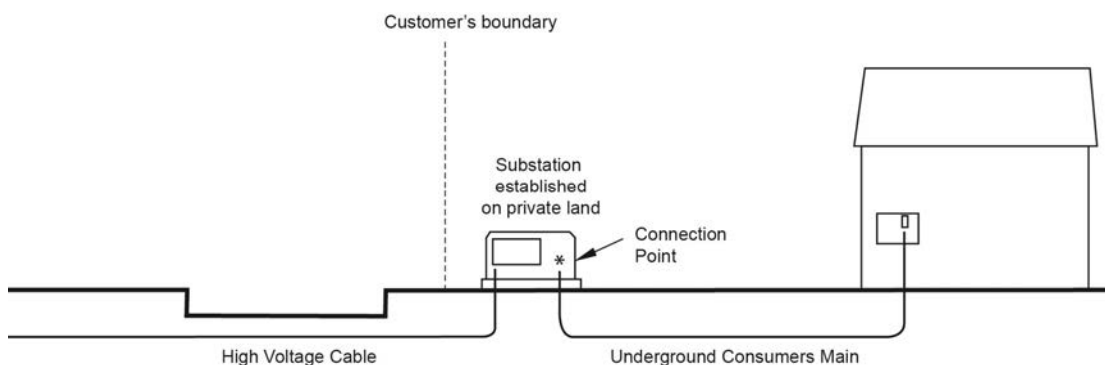

**(e) Underground Services from Substation on relevant land**

Note that in this case, the Point of Common Coupling could be the:

- Connection point – if other future LV customer connections are likely, or,
- The High Voltage Connections for the High Voltage Tee line if assets are totally dedicated to the one installation, or,
- Any other point between the two options above depending on possible additional installation arrangements.

**Notes to figures 1.1 and 1.2**

\* A connection must be able to be made at the Connection Point.

Note: for figure 1.2, a terminal enclosure, pit or pillar is required if the service would exceed 50 metres. Refer to Clause 2.6.2.

Additional drawings may be added in later editions of the Rules.

## 1.9 GENERAL

### 1.9.1 Introduction

The objective of these Rules is to achieve the minimum standards for providing safe, reliable and efficient connection services to customers.

The Rules:

- (a) Define the Connection Point as required by the Electricity Supply Act
- (b) Give guidance and minimum requirements for the provision of customer connection services.
- (c) Should be followed unless there is an agreed alternative course of action, which achieves the same or better result.
- (d) Can be used in support of enforcement provisions of the Electricity Supply Act.
- (e) Can be used to support prosecution for failing to comply with or contravening provisions of the Electricity Supply Act or associated regulations.
- (f) Are consistent with the NSW electricity distribution industry's requirements for preserving market integrity, security, reliability and safety of the system while minimising interference between and to its customers.

The Rules establish conditions for connection of Electrical Installations to the electricity distribution system and are complementary to:

- (a) Electricity (Consumer Safety) Act 2004 covering:
  - i) Electrical Installations (including meters)
  - ii) Electrical articles.
  - iii) Electrical apparatus and appliances.
  - iv) Accident reporting and investigation.
- (b) Electricity Supply Act which requires the electricity distributor to:
  - i) Connect customers under the provisions of a customer connection contract.
  - ii) Develop and implement a plan setting out policies, practices and procedures with respect to the conduct of affairs.
- (c) Electricity (Consumer Safety) Regulation 2006 covering among other things:
  - i) Safety of electrical installations.
  - ii) Notification of installation work.
  - iii) Testing of installation work.
  - iv) Maintenance of existing electrical installations.

- (d) National Energy Retail Law (NSW) covering:
  - i) Customer rights.
  - ii) Standard form customer contracts.
  - iii) Appeals.
  - iv) Customer protection.
- (e) Electricity Supply (Safety and Network Management) Regulation 2014 which requires electricity distributors to develop and implement Safety Management Systems covering Electrical Installation of Customers for the purposes of managing bushfire risk associated with aerial lines and equipment.,
- (f) Australian/New Zealand Standard 3000 'Electrical installations' (Wiring Rules).

The electricity distributors recognise these Rules as the industry standard.

The customer connection contract specifies these Rules, which describe the electricity distributor's requirements for connecting electricity supply.

These Rules must be read together with the terms and conditions of the electricity distributor's customer connection and customer supply contract.

### 1.9.2 Regulatory Provisions

The Electricity Supply (Safety and Network Management) Regulation 2014 requires each distributor to prepare and implement a Safety Management System covering

- (a) Network Safety and Reliability.
- (b) Public Electrical Safety Awareness.
- (c) Bush Fire Risk Management (including for Electrical Installations of Customers under certain circumstances).

The Regulation also provides that in determining the content of its Safety Management System, a distributor must take into account codes, standards and guidelines specified by the Minister by notice in writing to the distributor.. The Safety Management System must specify where it departs from the requirements of any such code, standards or guideline and what arrangements are in place to ensure an equal or better outcome.

### 1.9.2.1 Codes Notified by the Minister

The notice required the distributors to take the following Codes into account in relation to their Safety Management System:

- (a) ENA DOC 001 - National Electricity Network Safety Code.
- (b) DRE NSW Code of Practice - Contestable Works. (Replaced by the NSW Accreditation Scheme Rules)
- (c) DRE NSW Code of Practice - Service Standards.
- (d) The NSW Industry Safety Steering Committee ISSC 31 Guideline for the Management of Private Lines.
- (e) DRE NSW Code of Practice - Service and Installation Rules.

The Code of Practice - Service and Installation Rules incorporates these Rules by reference.

### 1.9.3 NSW Fair Trading

NSW Fair Trading administers the licensing and certification of electricians and undertakes disciplinary action under the Home Building Act 1989. Electrical contractors are responsible to their customers for matters under the Act, including statutory warranties for work that they, their employees and subcontractors do.

NSW Fair Trading may also investigate customer complaints and disputes about electrical installation work. The Electricity (Consumer Safety) Act 2004 requires that electrical installation work on an installation comply with relevant Regulations (refer to subsection 1.9.4).

Electricity distributors assist in this regard by maintaining an effective liaison with NSW Fair Trading through their system of audit inspection programs and reports on the investigation of shocks on customers' Electrical Installations. NSW Fair Trading also investigates complaints about electrical contractors under the Fair Trading Act 1987, the Australian Consumer Law and administers the Electricity (Consumer Safety) Regulation 2006. This includes the issue of certificates of approval for 'declared' electrical articles under a compulsory scheme and certificates of suitability for 'non-declared' articles.

This Regulation ensures that the equipment complies with relevant Australian Standards and any other minimum safety requirements.

### 1.9.4 Licensed Electrical Worker Requirements

#### 1.9.4.1 General

The Home Building Act 1989 requires that work on the fixed wiring of an electrical installation may only be carried out by:

- (a) A person holding a Qualified Supervisor Certificate; or
- (b) An individual holding an Electrical Contractors Licence endorsed as the qualified individual ("Q").

#### 1.9.4.2 Exemptions

There are a number of exemptions to the above general requirement:

- (a) A person holding an Australian recognised qualification "Tradesperson Certificate" relating to electrical wiring and under the directions and supervision of a holder of a Qualified Supervisor Certificate.
- (b) An apprentice or trainee involved in the undertaking of wiring related to their trade and under the directions and appropriate supervision of a holder of a Qualified Supervisor Certificate.

In all cases above the "Licensed Individual" will take responsibility for the standard, correctness and alignment with required NSW Codes or Guidelines and relevant Australian Standards.

Note: There are severe penalties where parties breach the above requirements.

### 1.9.5 Working Live Information for Electrical Workers

The Work Health and Safety Act 2011 and the Work Health and Safety Regulation 2011 Division 4 requires:

- (a) That electrical work is not carried out while the circuits and apparatus of the part of the electrical installation that is being worked on are energised.
- (b) That any electrical work on an electrical installation is carried out using a safe system of work, which must include checks to ensure that the circuits and apparatus of the part of the installation that is being worked on are not energised before work commences and remain that way until the work is completed, and measures to eliminate or control the risk of the person carrying out the work inadvertently contacting any part of the installation that remains energised.
- (c) Generally, live electrical work cannot be justified. The only variation to this requirement is where the electrical work is necessary in the interests of safety and the risk of harm would be greater if the circuits and electrical apparatus were de-energised before the work commenced.

Only in this situation can live electrical work proceed. The work must be performed in the presence of a safety observer competent to perform the particular task to be carried out and competent in electrical rescue and CPR. The safe system of work also

encompasses a list of other mandatory safety measures.

- (d) Testing and fault finding on live circuits must be carried out using a safe system of work including a risk assessment in respect of the tests and a list of other mandatory safety measures.

Note: The risk assessment may identify the need for presence of a safety observer who is competent to assist the persons who are conducting the tests and competent in electrical rescue and CPR.

Safe Work Australia has produced a Code of Practice: Managing Electrical Risks in the Workplace.

The Code provides practical guidance for persons conducting a business or undertaking on managing electrical risks in the workplace. It applies to all workplaces where a person conducting a business or undertaking:

- has management or control of electrical equipment, including electrical installations, or
- carries out electrical work on or near energised electrical equipment, including electrical installations.

This Code also applies to construction and demolition sites, except if a requirement of the Code is dealt with in AS/NZS 3012:2010 *Electrical Installations- Construction and demolition sites*. In that case you must comply with AS/NZS 3012:2010.

For further information contact your local WorkCover NSW offices listed in the telephone directory or ring the WorkCover Assistance Service on 13 10 50 or visit WorkCover's website [www.workcover.nsw.gov.au](http://www.workcover.nsw.gov.au)

### 1.9.6 Obligatory Requirements

Legislation permits the electricity distributor to state its requirements in relation to an electrical Installation of a Customer.

The electricity distributor may:

- (a) Impose conditions on the installation and use of electrical appliances and equipment to prevent or minimise adverse effects on the supply to other customers.
- (b) Impose conditions on the loading, and the balancing of the load, over the phases of the customer's supply.
- (c) Require a minimum rupture rating or minimum breaking capacity of the customer's main protection devices.

- (d) Require the customer to install relays, current transformers and other protection equipment having characteristics to suit the electricity distributor's protection system.

- (e) Require the customer to provide free of cost, for use of the electricity distributor, suitable accommodation for transformers, switchgear and other equipment.

The electricity distributor may also:

- (f) Make additional requirements where allowed by AS/NZS 3000.

- (g) Make an interpretation of AS/NZS 3000.

### 1.9.7 Damage

A customer may be held liable for the total cost of any damage caused by the customer to the electricity distributor's equipment installed on the premises.

### 1.9.8 Damage to other Utilities

Accredited Service Providers are liable for the total cost of any damage caused to other utilities during service work. They must notify the relevant utility and the customer, and arrange for the repair of damage caused.

### 1.9.9 Clearance to other Utilities

The specified clearance should be maintained between the installed overhead / underground service and services of other utilities.

#### 1.9.9.1 Navigable Waterways and Electricity Assets

Under the NSW Ports and Maritime Administration Act 1995, obstructions and encroachments must not be constructed in, on or over a navigable waterway without prior approval of Roads and Maritime Services (RMS) and must not constitute an obstruction to navigation. This applies to overhead (i.e. aerial), underground or submarine wiring systems including services, consumers mains, submains or final sub circuits.

It is the customer's responsibility to establish whether the waterway is navigable and to obtain all necessary approvals from RMS.

Whilst formal advice should be sought from RMS, requirements are likely to include that design, construction, operation and maintenance complies with AS 6947: Crossing of Waterways by Electricity Infrastructure.

## 1.10 Electricity Supply

The supply of electricity to a customer's premises is subject to interruptions and fluctuations and other disturbances that affect supply quality.

Customers should consider the need for equipment to have sufficient protection to extreme voltage fluctuations to protect against:

- (a) Storms and lightning.
- (b) Partial loss of supply, i.e. loss of one or two phases of a three phase supply.

### 1.10.1 Supply at 230/400 Volts (low voltage)

Supply is an approximately sinusoidal AC wave form with a frequency of 50Hz and nominal voltage of 230/400 volts from a three phase four wire distribution system. In outlying areas, the supply may be from a single phase 230/460 volt three wire distribution system.

The normal 50Hz sinusoidal wave form may be modulated by signal frequencies for electricity distribution control and communication.

See AS 60038 'Standard voltages' and AS 61000.3.100 Steady state voltage limits in public electricity systems, for details. If the 10

minute average voltage at the main switchboard (measured with reference to AS 61000.3.100) exceeds 253V with no load or generation connected the electricity distributor should be contacted.

### 1.10.2 Supply at 230/460 Volts (low voltage)

In areas limited to 230/460 volt supply, contact the electricity distributor for advice on special supply arrangements. These systems are 2 or 3 wire distribution systems with 180-degree phase displacement.

### 1.10.3 Supply at High Voltage

Electricity supply may be provided at higher voltages if required. Contact the electricity distributor for advice on high voltage supply arrangements. Refer also to Section 7.

### 1.10.4 Supply from the Railway Distribution System

For electrical installations on railway land or supplied from the railway HV distribution system contact ST.

## 1.11 Provision for Services, Service and Metering Equipment

### 1.11.1 Service Specification

Access to the service and termination points must be readily available

1.11.1.1 The electricity distributor may determine:

- (a) The type, location and installation of service equipment, including network control devices.
- (b) The type and rating of Service Protection Fuses/service circuit breakers.
- (c) The type, size and minimum rating of service conductors.
- (d) The construction and route of services.
- (e) The accommodation of any transformers, switchgear and other electricity distributor equipment on the customer's premises.
- (f) The Point of Common Coupling.
- (g) The location of the connection point.
- (h) The position of the POA of an overhead service to any building, pole or structure (customers may negotiate the position with the electricity distributor if feasible).
- (i) The property boundary entry of an underground service and the enclosure of the service cables.

1.11.1.2 A Metering Provider may determine the location of meters, required to service retail customers, in an Electrical Installation

1.11.1.3 Where alterations or additions are being carried out on an electrical installation, existing services, consumers mains and service and metering equipment must be replaced (by the customer) to comply with these Rules, where their current carrying capacity is exceeded by the maximum demand determined in accordance with AS/NZS 3000.

Information is provided on the electricity distributor requirements in the relevant Sections of these Rules.

1.11.1.4 Non-distributor poles such as communications poles should not be used without prior consultation with and approval of both the pole owner and electricity distributor. See Clause 2.10.5.

### 1.11.2 Advice to Contractors

The customer/contractor is required to initiate and make arrangements for services and service and metering equipment, including the location of:

- (a) Service and metering equipment (determined in the service specification clause of the Rules),
- (b) Point of Common Coupling, and,
- (c) Connection point

(in accordance with these Rules).

For electrical installations on railway land contact ST.

A service connected by an Accredited Service Provider shall only be done so after any and all payments from the connecting customer of any reimbursements due under any pioneer scheme arrangements have been made (refer to the National Electricity Rules and distributor customer connection contracts for details of the pioneer scheme).

A service may be disconnected by a distributor at its discretion where an unpaid pioneer scheme contribution exists.

Any disconnection and or reconnection costs incurred by a distributor as a result of breach of this paragraph will be passed on to the customer in addition to unpaid pioneer scheme contributions. Further, any person who connects a service prior to ensuring pioneer payments are completed may become liable in any legal proceedings, including recovery of unpaid pioneer scheme contributions, subsequent to their actions where a breach of this paragraph occurs.

### 1.11.3 Services

The electricity distributor may require the customer to do any of the following:

- (a) Supply and install an overhead or underground service.
- (b) Provide for attachment of an overhead or installation of an underground service.
- (c) Provide for more than one connection point if the electricity distributor considers it necessary. (e.g. to avoid interference with supply to any other customer).

The electricity distributor may, upon a customer's formal application, provide a service to an electrical installation.

The terms and conditions of the service arrangements may include the need and cost, if any, to extend or reinforce the existing distribution system and the coordination of these activities.

Customers are required to give adequate notice of electricity supply requirements so that the electricity distributor can meet the customer's schedule.

#### 1.11.3.1 Minimum Insulation Resistance

The insulation resistance between conductors and between conductors and earth of new services shall not be less than 50 megohms

when tested using a 500V DC insulation resistance tester.

#### 1.11.3.2 Number of Services

Only one connection point will normally be provided to each electrical installation. A strata title development will normally be considered as one installation. The electricity distributor may vary these arrangements.

An electricity distributor may allow more than one electricity network connection per installation if the distributor considers that to do so would be sound engineering practice after taking into account any or all of the following:

- (a) The magnitude of the customer's load;
- (b) The distance between 'sub installations' within an installation;
- (c) The nature of the customer's activities
- (d) The site conditions; and
- (e) The ongoing segregation of the separate parts of the installation.

The customer may be required to pay the cost involved in providing an additional supply. Before starting work, the electricity distributor must be consulted.

#### 1.11.3.3 Number of Phases

The number of phases required to supply an installation must be determined by:

- (a) The maximum load permitted by the electricity distributor in accordance with Table 1.1;
- (b) Possible restrictions on meter loading limitations as advised by a metering provider, and
- (b) The load characteristics of customer's equipment, eg three phase motors, instantaneous water heaters, 400V welders, large heat/air conditioning loads.

**Table 1.1: Allowable Number of Phases**

Maximum Demand	Number of Phases
Not exceeding 100A	One phase and neutral
Exceeding 100A	Two or three phases and neutral
A motor exceeding 2.0 kW	Three phases and neutral

Note: Determine the maximum demand in accordance with AS/NZS 3000 for consumers' mains and submains.

#### 1.11.3.4 Voltage Drop / Rise

The voltage drop in the overhead or underground service should not exceed 3% of the nominal voltage at the PCC, unless approved by the electricity distributor. The voltage drop must be calculated using the maximum demand of the consumers mains. Determine the maximum demand in

accordance with AS/NZS 3000 for consumers' mains and submains.

Where embedded generation is connected, the maximum permissible voltage rise on the underground or overhead service must not exceed 1%. See Table 8.3 for recommended maximum conductor lengths.

#### 1.11.4 Overhead Service

The overhead service terminates at the connection point. However, the electricity distributor may nominate an alternative point on the customer's premises, e.g. if a service does not originate on a public road or future undergrounding of the street mains is planned.

Section 3 provides details of requirements for overhead services including:

- (a) Determination of the route of the overhead service.
- (b) Means of support required to satisfy cable sag, tension and clearance requirements.
- (c) Termination and connection of the service to the electrical installation.

**To ensure bush fire risk management is addressed, Accredited Service Providers and electrical contractors must obtain electricity distributor requirements prior to installing overhead services in rural areas.**

The electricity distributor ensures maintenance of the overhead service, including service support(s) is carried out on the customer's premises. The customer will be responsible for:

- (d) Installation and maintenance of any support to the electricity distributor's requirements for the overhead service that is on the customer's premises.

Note: The customer must make arrangements with the electricity distributor or an authorised accredited service provider for the maintenance of a private pole on the customer's premises that has a physical connection to the distribution system.

- (e) Installation and maintenance of any aerial consumer mains that are connected to the overhead service.
- (f) Maintenance of required clearances between the overhead service and trees, vegetation on customer's premises (except in certain circumstances).
- (g) Maintenance of required clearance between the overhead service and any building, structure or ground on the customer's premises.
- (h) Installation and maintenance of the electrical installation which originates at and includes the connection point.

#### 1.11.5 Underground Service

The underground service terminates at the connection point. This is a termination pillar or facility, or the main switchboard located on the customer's premises. Refer to Figure 1.2.

Section 2 provides details of requirements for underground services including

- (a) Underground installation requirements.
- (b) Termination and connection of the service to the electrical installation.

The electricity distributor must ensure maintenance of the underground service is carried out.

The customer is responsible for the installation and maintenance to the electricity distributor's requirements, of any conduit or structure and equipment which is required to be located on their premises for the installation and connection of an underground service.

In addition, the customer must provide and maintain satisfactory access to the conduit or structure to avoid any unnecessary delay and inconvenience should work have to be carried out on the underground service.

The costs of excavation or reinstatement of finished surfaces (driveways, paths, etc) or demolition and reconstruction of civil works on the customer's premises - to enable the electricity distributor to gain access to the underground service to effect any future repairs - must be borne by the customer.

#### 1.11.6 Underground Service Connection to an Overhead Distribution System (UGOH)

##### 1.11.6.1 Provision for Future Underground Distribution System

In existing overhead distribution areas, the electricity distributor may require the provision of transition arrangements to provide for future undergrounding of street mains and services. In such cases, the arrangement will be deemed to be a combined overhead and underground service. Refer to Figure 1.1(c).

##### 1.11.6.2 Underground Supply from Overhead Distribution System (UGOH)

A customer requested underground service may be provided from the overhead distribution system by an underground to overhead connection at a suitable existing electricity distributor pole. Refer Figure 1.1(d) and Section 2 for further information.

#### 1.11.7 Special Small Services

Special small services refers to an overhead or underground service to connect supply to certain small electrical installations, usually located in public places eg bus stop shelters,



public conveniences, floodlights, decorative lighting, locality signs, public telephones etc.

Section 5 provides the detailed requirements for special small services.

### 1.11.8 Special Situations

The following situations require special consideration. The electricity distributor should be consulted for advice.

**Historic** - Consult the owner or the gazetted authority if a building or an environment feature has, or appears to have, historical significance. Do this before carrying out any work.

**Isolated or Non-Urban Areas** - Special conditions may apply to the provision of supply to these areas.

**Old City Districts** - Alternative methods of supply may need to be considered for old buildings.

**Public Facilities** - Services to public facilities (e.g., telephone cabinets, public conveniences, display lighting and traffic lights, etc) usually require special agreements with the electricity distributor.

**Shopping Centres** - If alterations are required to existing supply arrangements, the customer should contact the electricity distributor for information on issues such as whether:

- An additional connection point may be required,
- The customer has to provide additional space for distributor and or metering provider equipment, and or,
- an overhead, a facade mounted, or an underground supply will be provided.

### 1.11.9 Installations on Railway Land

Special conditions apply to services, service and metering equipment (and electrical installations) on railway land due to:

- (a) Ownership of the land by the railways.
- (b) Special railway operational requirements due to running trains.
- (c) The overhead 1500V dc electrified track area (refer clause 1.2.26).

ST is the contact point for all electrical installations on railway land in the railway 1500V dc electrified track area, due to special earthing, bonding and isolation requirements.

It is also the distributor for customers in other areas who are supplied from its high voltage distribution system (refer clause 1.2.26).

In the NSW railway 1500V dc electrified track area electricity supply to the rail network is either from the rail high voltage distribution system, or from the local electricity distributor where there is a requirement to establish a small low voltage distribution system which includes a special isolation transformer to

isolate the local electricity distributor's MEN earthing system from the rail earthing system.

In certain cases a changeover contactor is provided with the normal supply being provided from the rail HV distribution system and the back-up supply originating from the local electricity distributor but conveyed on railway land via the small LV distribution system as detailed above.

Due to the 1500V dc overhead wiring traction system, installations on railway land do not use the MEN earthing system. Instead, they use a modified direct earthing system, which incorporates a reticulated insulated earthing conductor.

All applications for electricity supply in the railway 1500V dc electrified track area are to be made in writing as detailed in ST publications.

In the non-electrified track area, whilst electricity supply will normally be from the local electricity distributor (and a special isolating transformer is not required), applications must be made in writing to as detailed in ST publications to obtain approval for the proposed route along with details of any special conditions that will apply for the service where it is on railway land.

Refer to clause 1.10.7.1 for special earthing requirements for electrical installations.

Refer to Section 2 of these Rules regarding special requirements for underground services, and Section 3 regarding special requirements for overhead services.

### 1.11.10 Service and Metering Equipment

The customer's Retailer (via their Responsible Person) will appoint a Metering Provider who will require the customer to provide space for metering equipment on the customer's premises. Charges may apply for metering equipment, as determined by the customer's Retailer.

The distributor will require the customer to provide and install service equipment on the customer's premises.

For service and metering equipment refer to Section 4, which provides details.

#### 1.11.10.1 Current Transformer Metering

Where the maximum demand of an installation or separately metered portion of an installation is determined by the customer's Metering Provider to be in excess of 100A per phase or the rating of a whole current meter, it will be necessary to use meters which operate in conjunction with current transformers.

Refer to Section 4, which provides details of current transformer metering arrangements.

### 1.11.11 Alterations, Additions and Upgrades

Alterations, additions, or upgrading of existing:

- (a) Overhead service/underground service;
- (b) Service and metering equipment,

required by or for the customer must comply with these Rules.

For the purposes of subclause (a), a distributor may maintain, renew, upgrade or alter an existing service line without reference to the rules where that service forms part of the distribution network.

For the purposes of subclause (b), a changeover of physical devices in the conversion of metering from type 5 or 6 to type 4 does not constitute an alteration under these Rules. However, this exception does not exclude the installer from meeting the intent of the Rules in matters relating to safety including but not limited to Meter Protection Devices and fire rated mounting as required by the Rules.

### 1.11.12 Communications

The customer's Retailer may require the customer to provide for the installation of communication equipment for remote meter reading, energy control or other purposes.

### 1.11.13 Accommodation of Electricity Distributor's Substation Equipment

The distributor may decide the supply of electricity required by a customer is too large to be provided by a service from its low voltage street distribution mains. The electricity distributor may require transformers, switchgear and other distribution equipment to be installed on the customer's premises. This may also arise when the customer takes supply at high voltage.

The electricity distributor will, in such circumstances, require the customer to provide a place within the premises to accommodate the transformers, switchgear and other equipment free of cost.

The place provided must be:

- (a) Considered suitable by the electricity distributor.
- (b) Enclosed in a manner approved by and at no cost to the electricity distributor.
- (c) Provided with satisfactory arrangements for access and tenure.

The electricity distributor may want to use the equipment to supply other premises. It may install additional equipment within the enclosed place to supply other premises.

## 1.12 Payments for Equipment and Services

In accordance with the Electricity Supply Act and customer connection contract, the electricity distributor may require a customer to pay:

- (a) For the supply, installation, connection and maintenance of overhead or underground services, and service equipment.
- (b) For the alteration of supply arrangements due to a customer request or to rectify a contravention of the electricity distributor's requirements.
- (c) A contribution towards the extension or alteration of the distribution system to accommodate the customer.
- (d) A contribution for any reimbursement under applicable pioneer schemes

Electricity distributors must also comply with Australian Energy Regulator (AER) determinations on capital contributions (including associated miscellaneous charges) and recoverable works. Refer to the AER website for capital contribution determination. Subject to the requirements of the AER determinations, electricity distributors may establish and publish prices, terms and conditions, if any, for the above work.

### 1.12.1 Extension or Alteration of Distribution System

The distribution system at the intended PCC may not be capable of supplying the customer. Alterations may be necessary where the customer intends to install an electrical load that, because of its size or characteristics, may affect the quality of supply to other customers. Extensions generally apply where the electrical installation is a considerable distance from the existing distribution system.

Where the existing distribution systems are single phase, three phase loads would require an extension (and possible augmentation) of the distribution system and an upgrading of a transformer.

These conditions may necessitate work to alter, extend or upgrade the distribution system.

Customers therefore need to apply to electricity distributors so that arrangements can be determined.

### **1.12.2 Contestable Work**

Details of the competitive process are given in the NSW Accreditation Scheme Rules. Clause 1.13 provides further information on the accreditation and authorisation for Level 2 accredited service providers.

### **1.12.3 Avoid Premature Expenditure**

A person who wishes to connect an installation to the electricity distributor's distribution system or increase the capacity of an existing connection must complete an Application for Connection (AFC).

Customers are advised not to make commitments or payments (eg contractual arrangements), for designs, materials or works

until they receive advice from the electricity distributor about the terms and conditions of the customer connection and customer supply contracts that will apply to the supply of electricity.

The customer should consider the possibility of the load exceeding the proposed arrangements and make allowances to avoid future upgrading costs.

### **1.12.4 Demand Management**

Charges may be minimised or avoided by carrying out an appropriate Demand Management review of the size and type of loads proposed to be connected.

## **1.13 Accreditation and Authorisation for Level 2 Accredited Service Providers**

The Electricity Supply Act 1995 specifies requirements relating to the provision of customer connection services and allows customers to choose the supplier of those services which the customer funds. These are contestable works. (Refer to the NSW Accreditation Scheme Rules).

The work is subject to the electricity distributor's design, construction and installation standards and can only be performed by an accredited service provider chosen by the customer.

### **1.13.1 Accreditation**

Accreditation is intended to facilitate the outcomes outlined in the NSW Accreditation Scheme Rules as follows:

- (a) The works comply with the electricity distributor's requirements.
- (b) Persons undertaking the works are suitably trained and qualified.
- (c) Connections to the distribution system are only performed by individuals authorised by the electricity distributor.
- (d) In compliance with the electricity distributor's Safety Management System.
- (e) The safety, reliability and efficiency of customer connection services.

There are three levels of accreditation.

Level 1: Permits work on the electricity distributor's distribution system that is contestable work associated with connection of a customer's development.

Level 2: Permits contestable customer connection work between the PCC and the connection point and at the main switchboard (including Type 5/6 metering services). These Rules apply principally to Level 2 accreditation.

Level 3: Accreditation relates to the associated design work.

Accreditation is granted by Division of Resources & Energy, NSW Department of Industry, Skills & Regional Development in accordance with its accreditation scheme.

### 1.13.2 Authorisation

Individuals working for accredited service providers or sub-contractors of accredited service providers must be appropriately authorised in writing by the electricity distributor to undertake works on or near the electricity distributor's distribution system.

Authorisation is required for individuals performing the following work:

- (a) Connection of an electrical installation to the electricity distributor's distribution system or service at the PCC or at the connection point.
- (b) Disconnection or reconnection of an electrical installation at the PCC, connection point, Service Protection Fuse, meter, link or other equipment.
- (c) Installation, connection, disconnection or adjustment of equipment which has been sealed by the electricity distributor or is required to be sealed.
- (d) Working on or near equipment such as, service and metering equipment, service pillars, posts or structures, or lamp fittings that are the electricity distributor's property.

At the completion of the work the accredited service provider or the metering provider must perform tests on all work carried out to ensure its safe operation before connecting it to the distribution system. These tests must include polarity, phase rotation (before and after and where applicable), insulation resistance and earthing integrity. The tests will include both visual and instrument checks.

The main switch(es) must be sealed in the OFF position with a suitable tag(s) which only the customer's contractor (which may also be the accredited service provider) who tested the electrical installation may remove.

The accredited service provider or metering provider must not energise the installation past the main switch unless they are in possession of a copy of the relevant notification of electrical work being carried out in accordance with requirements of the Electricity (Consumer Safety) Regulation 2015 or have completed such a document indicating all tests required have been performed.

Energising of the electrical installation past the main switch(es) is the responsibility of the customer's contractor.

## 1.14 Notification of Service Work

The accredited service provider must complete a notification, in the format required, that contestable service work has been carried out. The notice is to be forwarded so as to be received by the distributor within two working days of completion of the work.

The notice must include:

- (a) The customer details.
- (b) The scope of the work performed.
- (c) The test results.
- (d) The accredited service provider's details.
- (e) The installing and testing authorised person's details.
- (f) The meter equipment information.
- (g) A plan showing the details of the service route.

- (h) National Metering Identifier (NMI), where provided by the customer.

Contestable service works include:

- i) Installation and connection of new overhead or underground services.
- ii) Disconnection/reconnection of overhead or underground services at the PCC.
- iii) Disconnection/reconnection of an overhead service at the connection point.
- iv) Installation or replacement of service and metering equipment.
- v) Energising new installations.

## 1.15 Connection and Disconnection of Electrical Installations

Legislation requires that electrical installations must comply with relevant safety standards at the time of connection and remain safe while connected to supply.

Disconnection by the distributor is possible if the contract conditions are not satisfied, but only after reasonable notice is given under customer connection / supply contracts.

The distributor's Customer Installation Safety Plan should be referred to for ensuring the provision of safe electrical installations.

### 1.15.1 Availability of Supply Capacity

Customers should give notice as specified by the distributor of their supply requirements so that appropriate arrangements can be made. This particularly applies where a customer intends to install items of equipment which:

- (a) Place significant electrical loads on the electricity distribution system.
- (b) May affect the quality of electricity supply to other customers.
- (c) Export to the network and may have adverse effects on the network or the customer's installation.

Failure to apply in writing to the electricity distributor may result in delays for connection.

It may be necessary to reinforce the electricity distribution system or impose special conditions or restrictions on the operation and use of the equipment prior to any upgrading work that may be necessary to ensure satisfactory operation of the equipment.

Application must be made in writing to the electricity distributor by way of an Application For Connection (AFC) form for the provision of customer connection services and supply of electricity to electrical installations:

- i) Where the maximum demand for new or alterations exceeds 100A for single phase installations.
- ii) Where the maximum demand for new or alterations exceeds 63A per phase for three phase installations.
- iii) All non-urban installations (refer Clause 1.2.16).
- iv) Where the premises are in isolated or undeveloped areas.
- v) New or redeveloped multi-residential installations.
- vi) Special small services.
- vii) New or altered CT installations.
- viii) Where alternate supplies are proposed see Section 8.
- ix) Installations containing air-conditioning without assisted start.
- x) On railway land in the railway 1500V dc track area, the application process is detailed in ST publications.
- xi) Or as directed by the electricity distributor.

### 1.15.2 Connection to Supply

Under the Electricity Supply Act 1995 a person who owns or occupies premises must apply to the electricity distributor to obtain approval for the provision of customer connection services to those premises. Refer to clause 1.6. Such services must be provided under a relevant customer connection contract.

Connection services to customers' premises may only be provided by accredited service providers and their individual employees, as authorised by the electricity distributor.

### 1.15.3 Permanent Disconnection and Removal of Supply

Only suitably accredited and authorised service providers are permitted to carry out the permanent disconnection and removal of:

- (a) Overhead and underground services.
- (b) Metering equipment (excluding contestable market metering).
- (c) Load control equipment (owned by the electricity distributor)

from customers' premises.

The accredited service provider must consult with the electricity distributor for each proposed job for its procedural requirements and formal permission to proceed.

The accredited service provider will need to forward to the electricity distributor a written request from the owner and written agreement from the occupier (customer) if not the owner. If the customer is non-franchise then the written agreement of their retailer (if not the electricity distributor) must also be forwarded.

Following disconnection, the accredited service provider must return to the electricity distributor:

- i) Recovered overhead service/underground service unless other arrangements are made with the electricity distributor; and any
- ii) Recovered metering equipment belonging to the electricity distributor; and
- iii) A completed Notification of Service Work (NOSW) form.

Non franchise customer metering equipment must be returned to the accredited Metering Provider.

### 1.15.4 Safe Installation

The Electricity (Consumers Safety) Regulation 2015 requires that installation work on a electrical installation must:

- (a) Be compliant with AS/NZS 3000 the Wiring Rules.
- (b) Not be connected to the network unless the electricity distributor has permitted the connection to its distribution system.

- (c) Before commissioning be tested for safe operation and compliance with AS/NZS 3000 by a person authorised under the Home Building Act 1989 to do electrical wiring work without supervision.
- (d) Be recorded and notified to the electricity distributor and the owner of the electrical installation within 7 days of:
  - i) Commissioning any installation work; and/or
  - ii) Completion of any safety and compliance tests.
- (e) Be maintained so as to ensure that:
  - i) The safe and satisfactory operation of the installation is not impaired by interference or damage; and
  - ii) The live parts of the installation remain properly insulated, or protected against inadvertent contact with any person; and
  - iii) The installation is not used in a manner that exceeds the operating limit imposed by the design or installation.

The electricity distributor may permit the connection of any installation work associated with alterations or additions to an existing installation, including submains and final sub circuits originating at a main switchboard, provided the conditions of clause 1.9.4 of these Rules are met.

Such permission would not include any installation work:

- (f) Forming part of a high voltage installation
- (g) Located within a hazardous area, or
- (h) Where the work causes supply of electricity to be incorrectly metered.

The electricity distributor reserves the right to cancel this permission where serious or repetitive breaches of the legislation and these Rules are committed.

### 1.15.5 Bush Fire Management

The Electricity Supply (Safety and Network Management) Regulation 2014 requires NSW electricity distributors to have a Safety Management System in place covering the management of bush fire risk relating to electricity lines including electrical installations of customers connected to the network.

Further, in accordance with the Electricity Supply Act 1995, in bush fire prone areas, distributors may require customers to rectify defective installations including vegetation management. Where such work is not carried out, distributors may carry out this work at the customers cost or alternately may disconnect an unsafe installation.

### 1.15.6 Inspection

Where an officer of an electricity distributor, an appropriately authorised Level 2 ASP or a representative of the NSW Fair Trading performs an inspection, including any tests as part of the inspection, the assessment is limited to what can be observed or checked. This will depend upon the state of completion of the installation and does not guarantee that the work complies with standards in every respect.

### 1.15.7 Disconnection

As a result of its inspection, the electricity distributor, an appropriately authorised Level 2 ASP or a representative of the NSW Fair Trading may disconnect, refuse to connect, or plan to disconnect supply to the installation or parts thereof that contravene AS/NZS 3000 or relevant installation provisions of these Rules.

When this occurs the electricity distributor, an appropriately authorised Level 2 ASP or a representative of the NSW Fair Trading will give written notice to the customer and/or the customer's contractor advising of the contravention or defect.

If the defect creates dangerous situations, the electricity distributor, an appropriately authorised Level 2 ASP or a representative of the NSW Fair Trading will take immediate disconnection action.

For defects of a minor nature the electricity distributor may allow connection subject to rectification being completed within a period stated in the written notice.

The electricity distributor may also disconnect or discontinue supply with reasonable notice to a customer for a breach of the customer connection or supply contract.

## 1.16 Provision for Customers Installation

### 1.16.1 Advice to Customers

**Customers should obtain advice about the terms and conditions that will apply to the connection and supply of electricity before they incur any expenditure or enter into any contract. Refer to clause 1.12.**

capacitors used in power factor correction of fluorescent lighting.

- (d) **Generating systems** which may have adverse effects on the network or the customer's installation.

The customer should take particular care to check that equipment in these categories complies with the limits and conditions imposed by the electricity distributor.

### 1.16.2 Limits on the Connection and Operation of Equipment

#### 1.16.2.1 General

The equipment in an electrical installation must be arranged and operated so as to minimise or prevent adverse effects on the distribution system and other electrical installations connected to the distribution system.

The effects may be considered under the following categories:

- (a) **Excessive fluctuations** - equipment which would cause excessive voltage disturbances on the distribution system as a result of large or fluctuating load demands, eg arc furnaces, welding machines, x-ray units, frequently started motors including air conditioning equipment. Must comply with AS/NZS 61000.3.3 or AS 61000.3.5 and AS/NZS 61000.3.11.
- (b) **Excessive distortion** - equipment which would cause excessive distortion of the supply wave shape, eg rectifiers, frequency converters, electronic load control devices, saturable reactors. Must comply with AS/NZS 61000.3.2, AS/NZS 61000.3.4 and AS/NZS 61000.3.12.
- (c) **Interference with frequency load control system** - equipment which would adversely affect the electricity distributor's load control equipment: eg shunt

The electricity distributor may refuse to permit the connection of equipment if it considers that the electricity supply to other customers would be adversely affected.

Note: Clauses 1.10.2.3 to 1.10.2.5 provide limitations and exceptions that are generally considered acceptable.

#### 1.16.2.2 Corrective Action

Where a customer's equipment creates undue interference and adversely affects the supply to other customers, the electricity distributor will require the customer to take corrective action. The customer must comply with this clause even if the electricity distributor has approved the connection of the apparatus or equipment causing the interference. This may involve the imposition of requirements which are more stringent than the general limitations given under clauses 1.16.2.3 to 1.16.2.5.

In this situation, and others where there may be doubt as to the effects of particular equipment connected, or intended to be connected, to supply, the customer should seek professional assistance.

#### 1.16.2.3 Limitations - General

The equipment may be restricted by the change in current that occurs when the equipment is switched on and off or between other operational settings. The magnitude and

frequency of the current changes are important factors. Table 1.2 provides a guide to limits that may be applied to equipment other than motors which are covered in clause 1.16.2.4.

**Table 1.2: Guide to Limits to Current Changes for Equipment Other than Motors**

Equipment Voltage (V)	Connection of Load	Switching Arrangements	No. of Supply Phases	Limit Applying to Changes of Line Current (A)	
				Fluctuating or Intermittent (four or more changes per hour)	Continuous or Steady (less than four changes per hour)
230	Line to Neutral		1	15	25
230	Line to Neutral	Phases not switched simultaneously	2 or 3	15	25
230	Line to Neutral	Phases switched simultaneously	2	25	25
			3	30	50
400	Line to Line (no neutral connected)	Phases switched simultaneously	3	30	50
			2	45	50

Notes to Table 1.2

- Equipment having "Fluctuating or Intermittent" line current changes includes welders, heating units controlled by thermostats or energy regulators, and repetitively switched machines eg, X-ray units.
- A number of individual appliances which are likely to be controlled by one switching operation eg, space heating installations, illuminated tennis courts etc. must be regarded as one appliance.
- Some equipment may be exempted from Table 1.2. See clause 1.16.2.5 Exemptions and Special Considerations.

### 1.16.2.4 Limitations - Motors

The starting current of motors, which is significantly higher than running current, can cause a significant fluctuation of the supply voltage. Motor installations with associated starting/control devices must be designed to ensure that the starting current will not cause the reduction in voltage measured at the connection point to exceed 5% for more than 20 milliseconds.

Table 1.3 provides a general guide for different types and uses of motors.

In areas limited to 230/460 volt supply, contact the electricity distributor for advice on special supply arrangements.

**Table 1.3: Limits of Motor Starting Currents**

Motor Type	Starting Current (A)
Single Phase, 230V	45
Three phase 400V Domestic	53
Three phase, 400V non Domestic	$3.3k + 53$
Three phase, 400V lift motor	200
Three phase, 400V fire and smoke control equipment	$1.5(3.3k+53)$

Note: k = the continuous output rating in kW of the largest motor in the installation or group of motors that are started simultaneously.

### 1.16.2.5 Exemptions and Special Considerations

The distributor may agree to the connection of equipment which does not meet the general limitations provided in Tables 1.2 and 1.3.

Equipment that may be exempted or be suitable for special consideration may include:

- Storage and instantaneous water heaters.
- Controlled load tariff equipment, where supply is only available during certain off peak hours.
- Appliances incorporating motors which are switched with another load component, provided that:
  - The total change in line current does not exceed the motor starting current limit of Table 1.3; and
  - The change in line current attributable to switching load other than the motor does not exceed the limit of Table 1.2.
- Motors which are not frequently started and which the distributor has assessed as being able to be connected without creating undue interference.



An installation may be less susceptible to creating adverse effects where it:

- (e) Is connected to a low impedance distribution system as may be found in urban areas; or
- (f) Is in the proximity of, or directly connected to, an appropriate size substation; or
- (g) Incorporates substantial power factor correction facilities.

Customers who consider their equipment and installation to merit special consideration should contact the distributor prior to implementing any changes.

### 1.16.3 Balancing of Load

The loading of an installation, or a separately metered part of an installation, which is supplied by more than one phase, must be arranged so that the maximum demand in an active service conductor is not more than 25A above the current in any other active service conductor.

The total current in the service neutral conductor of a three phase supply must not exceed the highest simultaneous current in any active conductor, including the effects of harmonic currents.

The electricity distributor may agree to other limits.

### 1.16.4 Protection from Prospective Short Circuit Currents

The electrical installation must be designed and installed so that it will perform satisfactorily under all fault conditions.

In determining the suitability of equipment for use at 230/400 volts supplied from a distribution system, the nominal prospective short circuit current at the PCC for services up to 400A will be as follows:

- (a) Suburban residential areas: 10 kA.
- (b) Commercial and industrial areas: 25 kA.
- (c) Installations on railway land supplied by the rail HV network: 6 kA.

For switchboards greater than 400A refer to clause 4.17.2.

In certain circumstances lower or higher values may apply eg, non - urban areas and direct connection at a substation. In these cases, and in the case of supply at high voltage, the electricity distributor will advise the customer on the appropriate conditions in writing.

### 1.16.5 Coordination of Protective Devices

The protective devices forming part of an electrical installation should operate in such a manner that a fault in the installation is unlikely to activate protective devices installed in the distribution system. In order to achieve this, the

electricity distributor will require all protective devices to be coordinated or graded with the service protective device(s).

Refer to Section 4, which provides the requirements for low voltage switchboards rated above 100A.

### 1.16.6 Sealing / Locking

The customer must provide for the fitting of seals or locks to service and metering equipment, or to parts of the electrical installation. The provision must be approved by the electricity distributor or in the case of metering, by the Metering Provider. Seals or locks must be affixed in circumstances where they are necessary in the opinion of the electricity distributor or required by law. These circumstances may include:

- (a) Preventing obstruction or diversion of the supply of electricity.
- (b) Avoiding interference to other customers supply.
- (c) Securing the control and metering of the electricity supply.
- (d) Any other purposes relating to the agreement with the customer.

In general, sealing or locking is required for all connections on the line side of the meters and certain other connections associated with metering.

Refer to Section 4 which provides details for sealing and locking methods.

### 1.16.7 Earthing

New electrical installations, and alterations or additions to existing installations must be earthed using a Multiple Earthed Neutral (MEN) system complying with the requirements of AS/NZS 3000.

- (a) The main earthing conductor or a bonding conductor must not be connected to the service neutral link or bar.
- (b) The MEN connection must be made at the first downstream consumers neutral link. All subsequent customer's neutral links installed at the service position/main switchboard must originate from the first downstream customer's neutral link (at which the MEN connection is established).

Exceptions may arise in high resistivity soil, high voltage installations, high neutral voltage, mining or similar large outdoor installations.

For specialist applications the electricity distributor must approve proposals for alternate earthing methods.

#### 1.16.7.1 Earthing Installations on Railway Land

Electrical installations on railway land in the railway 1500V dc electrified track area are to

be earthed (using a modified direct earthing system) by connection to a nominated terminal and in accordance with special isolation, earthing and bonding requirements, in particular:

- (a) Provision of a service earth link when nominated.
- (b) No earth to neutral connection to be made by the customer.
- (c) No separate electrical installation earth electrode to be installed.
- (d) Special minimum size for earthing and bonding conductors; and
- (e) Mechanical protection requirements.

Details will be provided on application by the party nominated in ST publications.

### 1.16.8 Installation Switchboards rated above 100A

Low voltage customer switchboards with ratings of more than 100A per phase may be subject to additional electricity distributor requirements. The customer must not proceed with work until they know:

- (a) The requirements for service and metering equipment.
- (b) The distributor's planning requirements.

Refer to Section 4, which provides the requirements for low voltage switchboards rated above 100A and metering arrangements.

#### 1.16.8.1 Control of Incoming Supply

Facilities complying with the requirements of AS/NZS 3000 must be provided on the customer's main switchboard to isolate all portions of the electrical installation from all possible sources of supply.

Apply to the electricity distributor for its requirements on the use of bus-couplers where multiple supplies are available.

#### 1.16.8.2 Multiple Supplies

Where the distributor agrees to provide an electrical installation with more than one connection point, the customer must ensure the supplies from each connection point are not paralleled within the installation.

In general, where a single switchboard is supplied from more than one transformer, and the electricity distributor does not permit the paralleling of supply transformers, each transformer must be connected to a separate section of the busbar.

The provision of bus section couplers to interconnect the separate sections of the busbar is optional provided such couplers are:

- (a) Installed and connected on the line side of the distributor's metering equipment.
- (b) Installed at the customer's cost.

- (c) Under the electricity distributor's control.
- (d) Provided with facilities for locking in the "off" position by the distributor's security lock. Locking facilities must accept a 10mm diameter shank. The lock must be provided at the customer's cost and will remain the property of the distributor.

Where a bus section coupler is provided, a warning notice with permanently engraved white letters, 6mm high on a red background, must be fixed adjacent to the lock at the bus section coupler. The warning notice must read:

**WARNING - THIS COUPLER IS CONNECTED ON THE LINE SIDE OF THE INSTALLATION MAIN SWITCHES.**

Where off-load isolators are used as the bus section couplers, an additional engraved label must be fixed at the point of operation to indicate that the isolator must not be operated under load.

#### 1.16.9 Identification

The electricity distributor requires marking on electrical installations to identify the purpose and relationship of equipment. The marking may be in addition to that required by AS/NZS 3000 where:

- (a) Premises are subdivided into multiple occupancies with separate electricity supplies. The marking is used to identify the occupancy and the switchboard that supplies it. This will involve corresponding legible and durable marking at both the main entrance of the occupancy and the corresponding meter and distribution board, or switchboard.
- (b) Installations are supplied by more than one service. The marking is used at the service and metering equipment and the main switchboards to identify the portion of the premises being supplied and the presence, location or operation of any alternative source of supply. In addition, a diagram showing the segregation arrangement must be attached to each main switchboard. All distribution boards must be labelled to indicate from which service they are supplied.
- (c) Installations are supplied from the rail network distribution system. The markings on the main switchboard must indicate that the installation is supplied from the rail network distribution system.

Refer to Section 4 which provides a guide to acceptable equipment labelling and identification procedures for large installations.

#### 1.16.10 Termination of Cables

The customer must provide suitable terminating devices if required and enough cable to allow termination at the PCC nominated by the distributor.

If the proposed cable is not single core insulated and sheathed cable, it must be suitable for termination to the electricity distributor's distribution system and equipment.

### **1.16.11 Power Factor Correction/ Capacitor Installation**

The customer must maintain the power factor of the electrical installation at a value not less than 0.9 lagging.

The electricity distributor may require metering of the installation, at an appropriate tariff, if the power factor of the supply taken by an electrical installation is such that either:

- (a) The distribution system is not, or would not be used efficiently, or
- (b) The supply to another customer is, or would be adversely affected.

The installation of power factor correction equipment, or in the case of the variation of any inductive load, must not:

- (c) Cause the power factor of the installation to become leading at any time; and
- (d) Adversely affect the operation of the electricity distributor's frequency injection load control system.

Refer to Section 6, which outlines requirements for installations which include capacitor power factor correction equipment.

### **1.16.12 High Voltage Installations**

Application must be made to the electricity distributor for the installation of facilities which will enable the connection of a high voltage installation to the electricity distributor's distribution system.

Installations incorporating high voltage equipment must comply with the electricity distributor's requirements and its Safety Management Systems.

Refer to Section 7, which provides further information on requirements for high voltage installations.

### **1.16.13 Private Generation**

#### **1.16.13.1 Standby Generation**

Where the customer installs an alternative source of electrical supply, eg a standby generator, the proposed arrangements must be approved by the electricity distributor. Approval must be given for facilities to connect the alternative source of supply to the electrical installation normally supplied from the distribution system.

Where the electricity distributor agrees to the installation of facilities to enable an installation to be disconnected from the distribution system and connected to the alternate source, the systems must comply with the electricity distributor's requirements. They must prevent the electricity distributor's service and metering equipment and distribution system from being energised by the alternative source.

A notice must be fixed to the main switchboard and other affected switchboards to show:

- (a) That the alternative supply facilities exist.
- (b) Which section(s) of the installation they can supply.
- (c) Their point of control.
- (d) The conditions under which they may be operated.

Refer to Section 8, which outlines requirements for installations including standby generation.

#### **1.16.13.2 Parallel Generation**

Application must be made to the electricity distributor for the installation of facilities which enable the connection of a privately owned generation plant to its distribution system.

Installations incorporating inter-connectable (parallel) generation must comply with the electricity distributor's requirements.

A customer requiring inter-connectable (parallel) generation will be required to comply with specific terms and conditions which may be incorporated in the customer connection contract.

The cost of designing, installing, operating and maintaining the private generating equipment is the customer's responsibility. Parallel operation of the generating equipment cannot commence until the electricity distributor gives written approval. The electricity distributor will advise of the conditions applicable.

Refer to Section 8, which outlines requirements for installations which include parallel generation.

For large (over 75kW) installations, the electricity distributor may require approval and inspection of the installation before the generator is connected to the network. A test operation may be necessary.

#### **1.16.14 Installations on Railway Land**

Specific conditions apply to electrical installations on railway land.

Contact ST for details.

#### **1.16.15 Identification of Lighting Installations (not owned by a distributor) in Streets, Parks or other Public Areas**

The above lighting installations must have a clear and indelible sign attached to the outside of each light fitting (or lighting pole or standard if applicable) that indicates that it is Private Lighting. The sign shall also include the ownership and identify the origin of supply in accordance with AS / NZS 3000. The height of the lettering shall be a minimum of 20 mm.

## 2 UNDERGROUND SERVICES

---

### 2.1 Introduction

This Section outlines the requirements for the installation of an underground service.

#### 2.1.1 Underground Service

The underground service extends between the electricity distributor's PCC and the connection point on the customer's premises.

The connection point is established at either a pillar/pit on the customer's premises, or at the customer's main switchboard. Refer to Figure 1.2.

#### 2.1.2 Underground Service from an Overhead Distribution System

The provision of an underground service from the electricity distributor's overhead supply is permitted by the conditions detailed in this Section and will be referred to as an underground supply from an overhead distribution system (UGOH).

#### 2.1.3 Specific Railway Requirements

Application in writing must be made to ST for the route and installation method for an underground service on railway land.

Special conditions apply, and will be advised on application.

Written approval from the party nominated in ST publications is required for any proposed route.

#### 2.1.4 Non-Distributor Pole Use

Non-distributor poles such as communications poles should not be used without prior consultation with the pole owner and distributor.

---

### 2.2 Service Route

#### 2.2.1 Special Considerations

The following factors should be taken into account:

- (a) Length and route of the service, including the part in the street. Obstacles such as trees, major shrubs and other public services should be taken into account.
- (b) Access to the service and metering equipment.
- (c) The location of the proposed and existing underground service, road crossings, and presence of other utilities (i.e. gas, water, and communications), service protection fuses and metering.
- (d) The location of any additional customer termination enclosure that may be required.

(e) The location of electricity distributor poles in the street if connecting to an overhead distribution system.

(f) A transformer or switchgear on the selected pole if connecting to an overhead distribution system.

#### 2.2.2 Crossing of Adjoining Property

The route should not cross an adjoining property. If there is no alternative, a suitable easement must be obtained.

#### 2.2.3 Access

The underground service termination points must have readily available access.

## 2.3 Underground Consumers Mains

### 2.3.1 General

Where the connection point is nominated on a transformer pole on relevant land, only Authorised Persons may undertake the installation or connection of consumer mains above 3 metres from ground level.

### 2.3.2 Electrically Un-Protected Consumers Mains

To provide similar performance characteristics to the underground service cable, electrically unprotected underground consumers mains must be installed using the same cable type and minimum size as specified for the underground service cable. Refer to clause 2.6.1.

### 2.3.3 Alterations and Additions

Alterations or additions to existing consumers mains must be treated as a new installation as per clause 1.11.11. This need not apply where additional phase conductors are added to existing electrically unprotected single-phase consumers mains, provided that the cross-sectional area of the additional conductors is not smaller than the existing conductors.

### 2.3.4 Electrically Protected Consumers Mains

Electrically protected underground consumers mains must comply with the requirements of AS/NZS 3000.

## 2.4 Installation of Underground Service

**Caution!**  
The installation of an underground service must only be carried out by an accredited service provider.

### 2.4.1 Installation Requirements

The customer is responsible for all costs and for providing all works and material in relation to installing an underground service cable.

All new service cables within the customer's property must be installed in conduit suitable for the drawing in and drawing out of the cable.

#### 2.4.1.1 Underground Service Cables installed in conduit

Underground service cables of less than 240mm<sup>2</sup> must be installed in conduit throughout their entire length.

Furthermore, underground services installed in conduits must meet the following requirements:

- (a) Cables must be installed in UPVC conduits as specified in AS/NZS 3000 for a Category A system enclosure, or as determined by the electricity distributor.
- (b) The underground conduit must be maintained a minimum 500mm depth throughout the entire length.

**Note:** Where the ground or obstructions prevent maintaining the 500mm depth, the underground wiring requirements of AS/NZS 3000 will prevail. The electricity distributor must be notified by the NOSW of the method used.

- (c) Orange marker tape must be installed 300mm above the underground conduit for its entire length. Marker tape is not required when under boring techniques are used to install an underground service. The marker tape must meet the requirements of AS/NZS 2648 'Underground marking tape - Part 1 Non-detectable tape'.

- (d) The cables of each underground service must be identified with a permanently installed water-resistant tag. The tag is to be indelibly marked to nominate the street number and name of premises supplied.
- (e) The cable ends must extend to a minimum of 1 metre above ground level.

#### 2.4.1.2 Underground Service Cables – direct buried

Underground service cables comprising circular multi core conductors 240mm<sup>2</sup> or larger may be direct buried.

The underground service cable must maintain 500mm depth throughout its entire length.

**Note:** Where ground material/obstructions prevent maintaining the 500mm depth, the underground wiring requirements of the AS/NZS 3000 will prevail. The electricity distributor must be notified via the NOSW of the method used.

Where the direct buried technique is used, the service cable/s must be mechanically protected by means of a light orange coloured polymeric cable cover strip of a material equivalent to UPVC conduit complying with AS4702 having a thickness not less than 3mm.

This cover strip will fulfil the requirements of a marker tape and must be positioned 300mm above the cable.

#### 2.4.1.3 Underground Service Cables – in a public reserve/easement (off the customer's property)

Where the underground service is installed **within the boundaries of a public road, public reserve or easement** (off the customer's property), the underground service must be installed in accord with the following:

- (a) 150mm lateral separation must be maintained between the underground service cable and the electricity distributor's cables and services belonging to other utilities.
- (b) Installed parallel to the property line and within the electricity distributor's easement or allocation or at 90° to the property line.
- (c) Specific requirements of the electricity distributor, (where applicable).
- (d) All relevant Acts, regulations and other statutory requirements, including notification requirements of local councils and restoration obligations in the public allocation.

#### 2.4.2 Searches for Underground Utility Services

The accredited service provider must carry out a search for underground utility services, prior to excavating. Adequate clearances must be obtained between the proposed underground service and underground utility services. Check with the appropriate utility to determine required clearances.

Utilities may include:

- water
- sewer
- drainage
- gas
- communication cables
- other power cables
- railway power, signalling and communication cables (which may also be located in public streets, parks etc).

#### Dial Before You Dig

Phone 1100 - free call (except from mobiles)  
Website [www.1100.com.au](http://www.1100.com.au)

Australia's major service providers have a single web-enabled information service for information on the location of underground communications, gas, water and electricity infrastructure. Use the website to ensure that you 'Dial Before You Dig' before any excavation work. If calling, be ready to provide the operator with:

- your name and address
- name of company
- contact telephone number
- fax number for return information
- contact name on site
- site address and both nearest cross streets
- start date of proposed work
- type of work being carried out

**Caution**  
**All buried cables must be considered as energised**

#### 2.4.3 Provision for other Utility Services on Customers Premises

Other utility services may be located in the same trench as the underground service provided they comply with the requirements of the AS/NZS 3000. Other utilities may have additional requirements.

#### 2.4.4 Position of Underground Service/Consumers Mains

##### 2.4.4.1 On the Premises

A sketch of the underground service/consumers mains route must be clearly marked on the inside of the meter enclosure or on the meter panel. Alternatively, a suitable sketch placed in a clear plastic envelope must be permanently attached either within the main switchboard enclosure or on the meter panel. Figure 2.5 shows a typical sketch.

##### 2.4.4.2 Off the Premises

When notifying the electricity distributor of completed works, the accredited service provider must supply a sketch detailing the route of the underground service off the customer's property. The Notification of Service Work (NOSW) is to be used.

Refer to Figure 2.6 for a typical sketch of the underground service route off the premises.

The sketch must clearly show:

- (a) Street alignments.
- (b) Lot boundaries.
- (c) Lot/house No's.
- (d) Name of street and suburb in which the work is being done.
- (e) North point.
- (f) Route of underground service.
- (g) Start and finish points of any conduits.
- (h) Reference the position of the service in the ground at all deviation points.
- (i) Depth of cover over the service.
- (j) Position of cable joints.
- (k) Type of cable used.
- (l) Type of joint made (if any).
- (m) The accredited service provider's full name and phone number.
- (n) Reference points from which all other measurements must be taken.

## 2.5 Conduit Requirements

### 2.5.1 Sizes

The minimum conduit size used to enclose an underground service cable is 40mm diameter.

### 2.5.2 Installing Service Conduits

Underground service conduits must be laid in a straight line and any conduit bend must be a sweep bend. Only one sweep bend with a minimum internal angle of 90° is permitted on the customer's premises, unless a termination enclosure is installed.

A minor deviation in the straight-line run of conduits is permissible, i.e. within the flexibility of the conduit. Do not use heat on the conduit to aid bending. Heat causes shrinkage.

Where the underground service cable terminates, in the meter enclosure, the conduit must enter the enclosure.

Where permitted by the electricity distributor, a draw-in box located on the external wall may be installed. The draw-in box is to be located above finished ground level.

The draw-in box must have an IP rating suitable for the area in which it is located.

A length of heavy duty corrugated conduit (up to 1.2 metre) may be used to allow the service cable to enter the cavity and meter box. Where exposed, this conduit must be covered by a steel guard.

The underground service may then pass through the wall into the cavity in such a way that will permit the cables to be drawn in or out without damage.

### 2.5.3 Joints

Join the conduit using sockets or fittings. Install the sockets or fittings so that the bore of the system is continuous and smooth and presents no obstruction to pulling in the cable. Make joints watertight. Bond them using an appropriate jointing method.

### 2.5.4 Draining

Install a drain in a conduit when the ground level at the street end of the conduit is above the floor level of a building in which the conduit terminates. Refer to Figure 2.1 for installation details.

Position the drain approximately 300mm above ground level. It should include:

- (a) A 10mm diameter hole facing the wall if the conduit rises on the outside of a building, or
- (b) A minimum 10mm diameter non-metallic pipe fitted into the conduit. The pipe must not protrude into the bore. Arrange the pipe so that it drains to the exterior of the building above ground level when the conduit is on the inside of a building.

Refer to Figure 2.1, 2.2, 2.3 and 2.4 for typical conduit installations details.

Figure 2.1: Typical Service Conduit in Domestic Premises

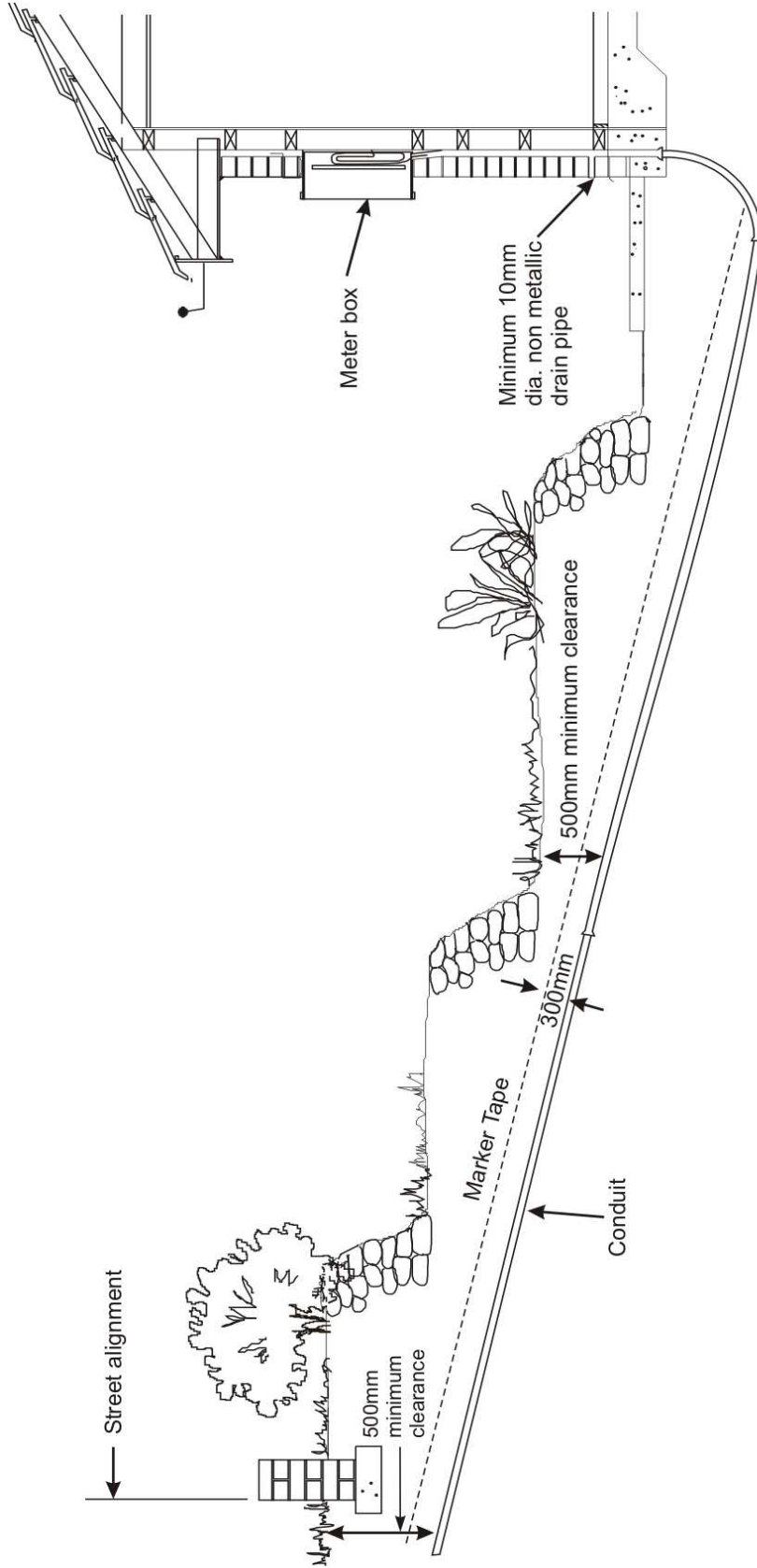

Install a conduit with a minimum diameter of 40mm.

The conduit is limited to 63mm when associated with a standard meter box panel due to the restricted space behind the panel.



Figure 2.2: Typical Service Conduit - Non Domestic

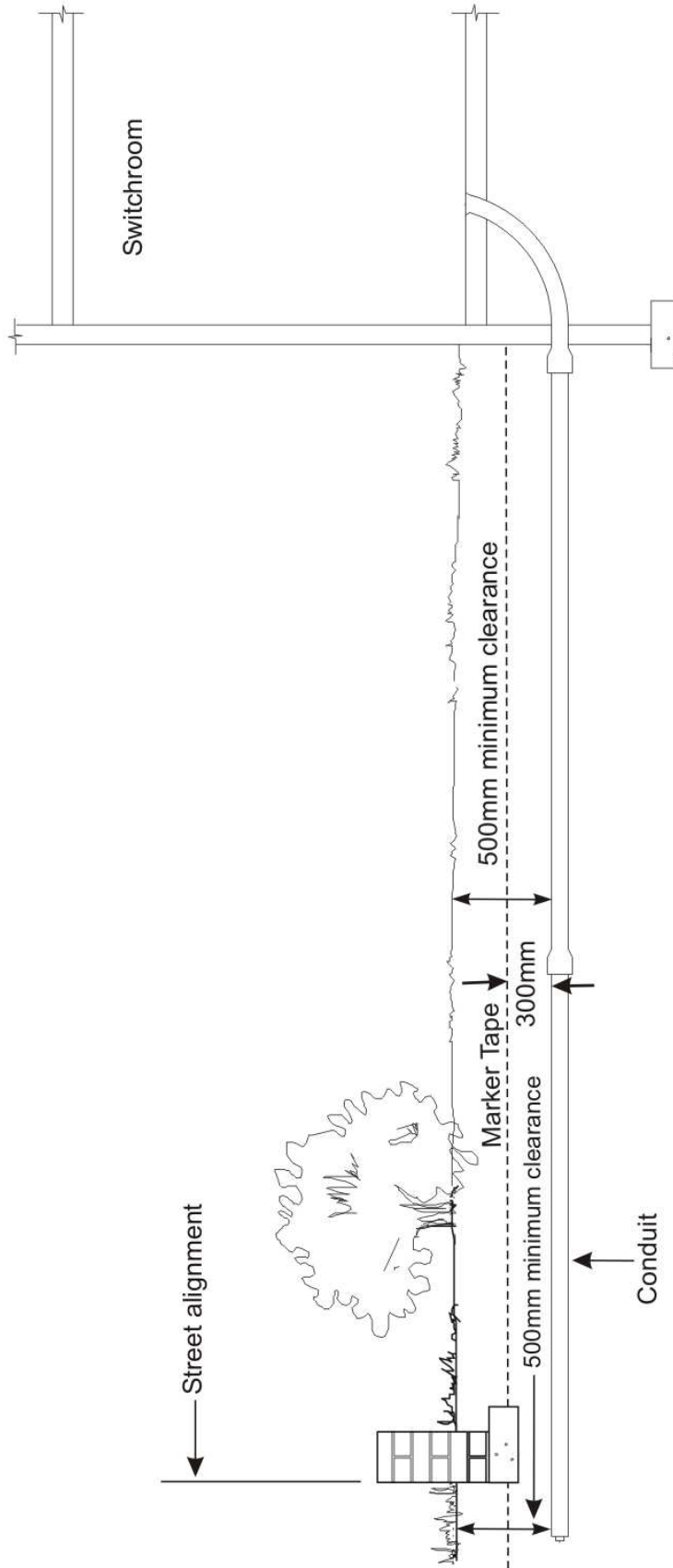

Install a conduit with a minimum diameter of 40mm.

The conduit is limited to 63mm when associated with a standard meter box panel due to the restricted space behind the panel.

**Figure 2.3: Typical underground service installation to customers termination enclosure - (pillar)**

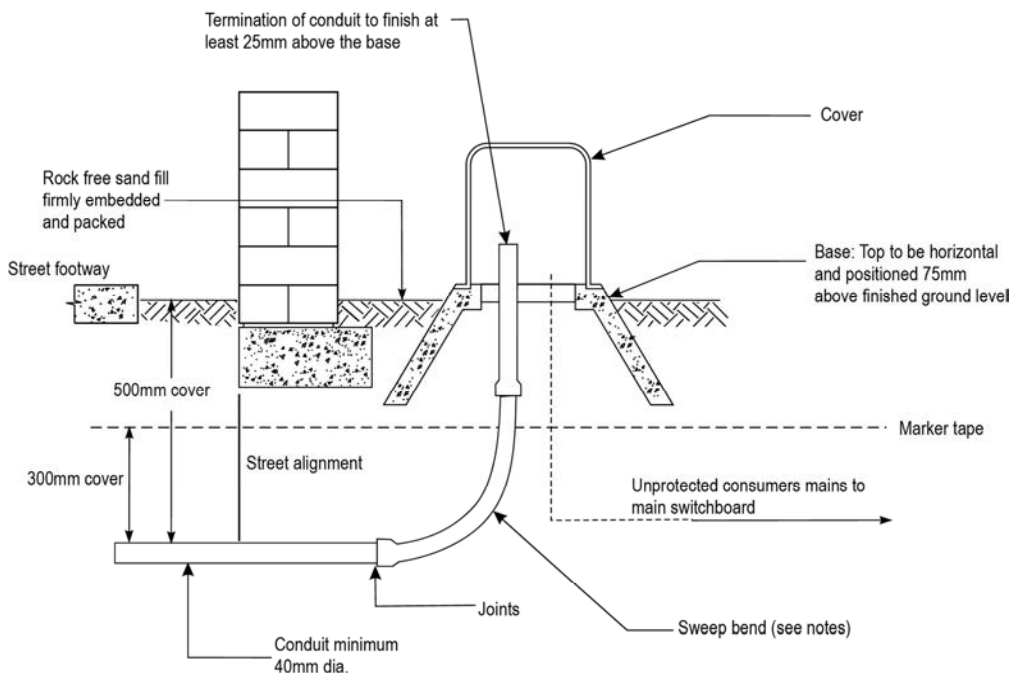

Notes:

1. For services rated above 100 amperes, the accredited service provider must on each occasion consult the electricity distributor.
2. Locate enclosure within 1 metre of the property alignment under which the underground service passes.
3. Marker tape 300mm above conduit (clause 2.4.1.1 (c)).
4. Only one sweep bend with a minimum internal angle of 90° is permitted on the customer's property.

**Figure 2.4: Typical underground service installation to customers termination enclosure - (pit)**

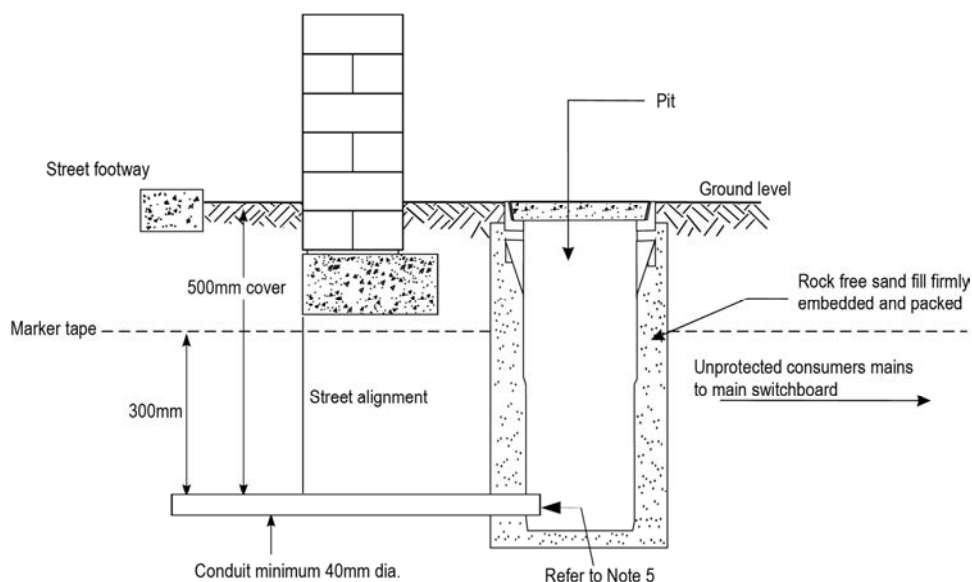

Notes:

1. For services rated above 100 amperes, the accredited service provider must on each occasion consult the electricity distributor.
2. Locate enclosure within 1 metre of the property alignment under which the underground service passes.
3. Top of pit to be level with final ground or footpath level.
4. Coil a minimum of 1500mm of service cable and consumers mains in the pit.
5. Service conduits are to extend at least 40mm into the pit.
6. Marker tape 300mm above conduit (clause 2.4.1.1 (c)).

## 2.6 Cable Requirements

### 2.6.1 Cable Specifications

The following information provides the minimum specifications for single and multiphase underground service cables:

All underground services must be four-wire three phase, except for single domestic premises, duplexes and builder's services. In these cases a two-wire single-phase service is permissible provided the service cable does not require a direct buried joint.

The cable size and service ratings are set out in Table 2.1.

Service cables must be XLPE insulated PVC sheathed, comply with AS/NZS 5000.1 Electric Cables–Polymeric insulated and be comprised of either:

- Single core cables; or
- One 4-core circular cable; and
- Must comply with AS/NZS 4026 Electric cables – for underground residential distribution systems.
- AS/NZS4961 Electric Cables – Polymeric insulated for distribution and service applications.

Service cables with a CSA of 240mm<sup>2</sup> must be of four-core aluminium, XLPE insulated, PVC-sheathed construction. Single core cables shall only be connected at pillars or to service tails. Check what method of connection is required prior to purchasing cable.

**Table 2.1: Service cable sizes and ratings**

Cable CSA (mm <sup>2</sup> )	Conductor Material	Cable Rating Amps	No. of Cable Cores
16	Cu	100	1 or 4
25	Cu	100	1 or 4
50	Cu	200	1 or 4
70	Cu	200	1 or 4
240	Al	400	4

Note:

4×185mm<sup>2</sup> CU1XQZ single core cables are acceptable alternatives for 400 Amp services in city locations, where it is physically impractical to install and terminate the 240mm<sup>2</sup> Al 4-core cable. Other locations may also be accepted, where the electricity distributor has granted prior approval.

Table 2.1 and the above note specify the **only** service cables that may be used for various service ratings. Any intermediate service ratings (based on the assessed demand of the installation) must use the next largest service rating/cable available.

The 50mm<sup>2</sup> cable may also be used for a 100 Amp service to satisfy the voltage drop requirement.

In addition, underground service cables must be brand new and joints are not permitted unless otherwise approved by the electricity distributor.

If these requirements are incompatible with the electricity distributor's design standards, the electricity distributor will specify the number and size of conductors and stipulate a method of termination. For example: where the PCC is buried directly in the ground, the underground service cable must comprise single core insulated and sheathed conductors.

Consult with the electricity distributor for services greater than 400 Amps.

### 2.6.2 Maximum Length

The maximum total length of an underground service is 50 metres providing the connection point is established at the main switchboard. Refer to Figure 1.2(a).

### 2.6.3 Non-Urban Installations

Where the PCC is located on the customers' property, and the underground service exceeds the maximum permissible length (50 metres), the electricity distributor will nominate the location of the connection point. Refer to Figure 2.8.

### 2.6.4 Spare Conductors

The authorised accredited service provider must energise any spare underground service conductors installed to provide for future phase connections.

Spare conductors are to be terminated in a sealable fuse or in a sealable link.

### 2.6.5 Alterations and Additions

Alterations or additions to an existing underground service or unprotected consumers mains must be treated as a new installation as per clause 1.11.11. This need not be applied where:

- Additional phase conductors are added to an existing single phase service cable or unprotected single phase consumers mains - provided that the cross-sectional area of the additional conductors is not smaller than the existing conductors; or
- The existing conduit is smaller than 40mm but is able to accommodate the additional or replacement conductors.

## **2.7 Connection Point Enclosure - Other than the Main Switchboard**

### **2.7.1 Enclosure**

An appropriately manufactured (with appropriate waterproofing and method of connections) electrical termination enclosure (pit or pillar) is required where the connection point is not established at the main switchboard.

### **2.7.2 Access**

The customer must supply and install the enclosure in a way that allows the underground service conduit to meet the requirements of these Rules, and provide unrestricted access from two sides and above.

The cover of the pillar/pit must, with the use of a tool, be totally removable from the base, allowing full access to the contents. Where the pit or pillar is prone to mechanical damage at or

above ground level, suitable mechanical protection must be installed.

### **2.7.3 The Termination Enclosure**

Where the connection point is not established at the main switchboard, the termination facility must be located within 1 metre of the property alignment under which the underground service passes.

The Termination Enclosure must be labelled either 'private pit' or 'private pillar'.

### **2.7.4 Labelling**

The top of the cover for the termination enclosure must be clearly labelled to indicate it contains electrical apparatus, eg, CAUTION ELECTRICITY and that the facility is a PRIVATE PIT or PRIVATE PILLAR. The height of the lettering must be at least 20mm.

## 2.8 Service Cable Connection Requirements

Authorised service providers should consult with the electricity distributor before carrying out service connection or disconnection work at pillars and pillar standards with exposed live parts, as restrictions on live work at these may apply.

Electricity distributors will supply details of their standard connection arrangements to accredited service providers working in their distribution area.

### 2.8.1 Colour Coding

The phase/neutral colour coding must meet the specifications of the AS/NZS 3000 requirements for consumers' mains.

### 2.8.2 New Termination Enclosure required in Public Area with existing Distribution System

Where a new PCC is established in a public area, the work must be carried out by an appropriately authorised, Level 1 accredited service provider. The electricity distributor will determine the need for the location of the enclosure.

### 2.8.3 Pit and Duct Systems

Where the electricity distributor's low voltage distribution system is installed as part of a pit and duct system, the connection will be made at a pit. Existing pits and ducts from the customers' premises must not be used without the agreement of the electricity distributor.

The electricity distributor will nominate the PCC and whether a new pit needs to be constructed. Where no suitable pit exists for connection, a Level 1 accredited service provider or the electricity distributor will supply and install one.

Only an accredited service provider authorised by the electricity distributor may work on or near an electricity distributor's pit or pillar.

Where a suitable cable entry is not provided in the pit, it must be installed by an appropriately authorised accredited service provider.

### 2.8.4 Phase selection for the Connection of Services

Single-phase customers should be connected to the following phase arrangement:

- reconnect existing service cable to the same phase as previously connected, or
- connect the new underground service cable as listed in Table 2.2.

**Table 2.2: Phase Selection**

For lot or street number ending in:	Connect to:
1	A phase
2	B phase
3	C phase
4	A phase
5	B phase
6	C phase
7	A phase
8	B phase
9	C phase
10	A phase
20	B phase
30	C phase

### 2.8.5 Earthing of Equipment

Where the sheathing is removed from an underground service cable installed within a metallic service or metering enclosure, the enclosure must be earthed in accordance with the equipotential bonding arrangements of the AS/NZS 3000.

### 2.8.6 Phase Selection for Single Phase Controlled Loads, Supplied from a 3 Phase Service

Where a single-phase controlled load (eg off peak hot water system) is installed on a premises supplied from a three-phase service, apply Table 2.2 for the connection of the single-phase controlled load.

**Figure 2.5: Typical sketch of the underground service route on the premises - to be placed in the main switchboard enclosure.**

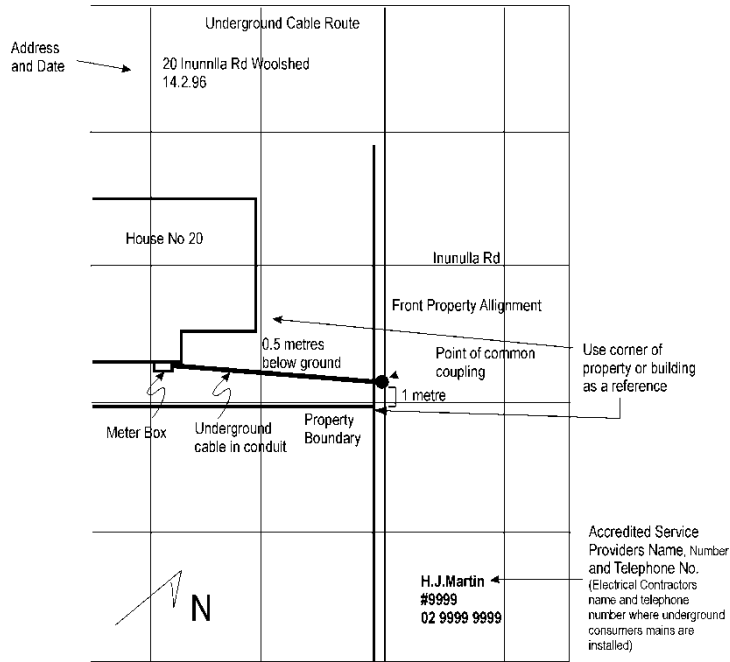

**Figure 2.6: Typical sketch of the underground service route off the premises - to be submitted to the electricity distributor by way of a Notification of Service Work form. This figure does not necessarily show the specific design requirements for a service installation.**

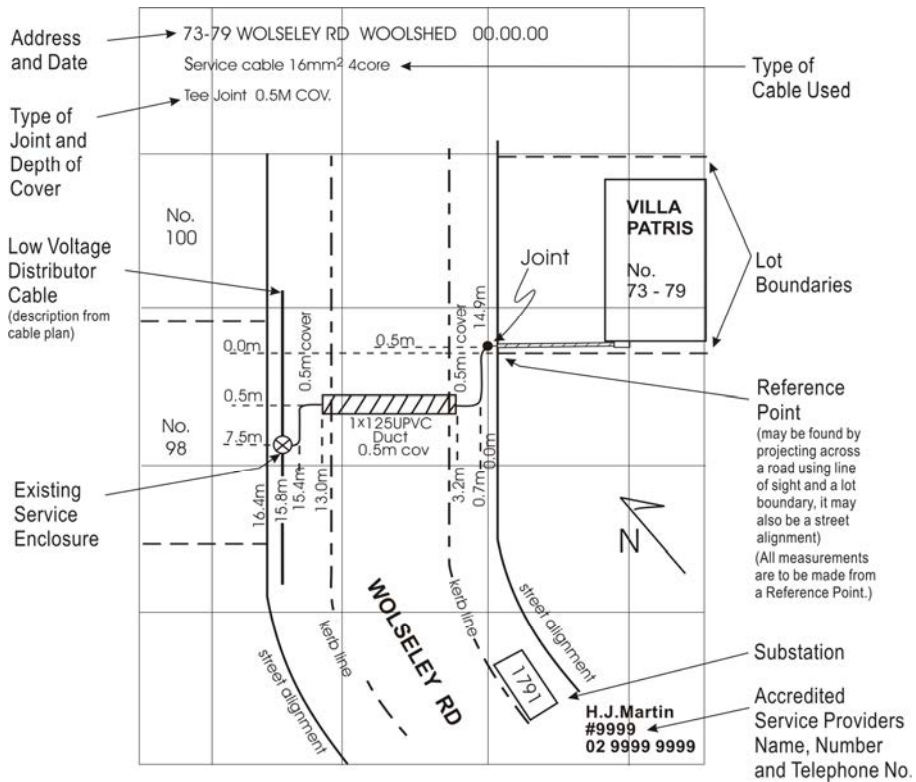

## 2.9 Temporary Support in a Permanent Position for Building Purposes

Supply may be taken via a metering enclosure/main switchboard, supported in a way that allows building construction to proceed. It must encompass the switchboard enclosure and secure it in its permanent building position.

Figure 2.7 shows a main switchboard temporarily supported to provide supply for building purposes. Other configurations of this support, provided they meet safety requirements, are acceptable.

**Figure 2.7: Typical main switchboard temporarily supported in permanent position to provide supply for building purposes.**

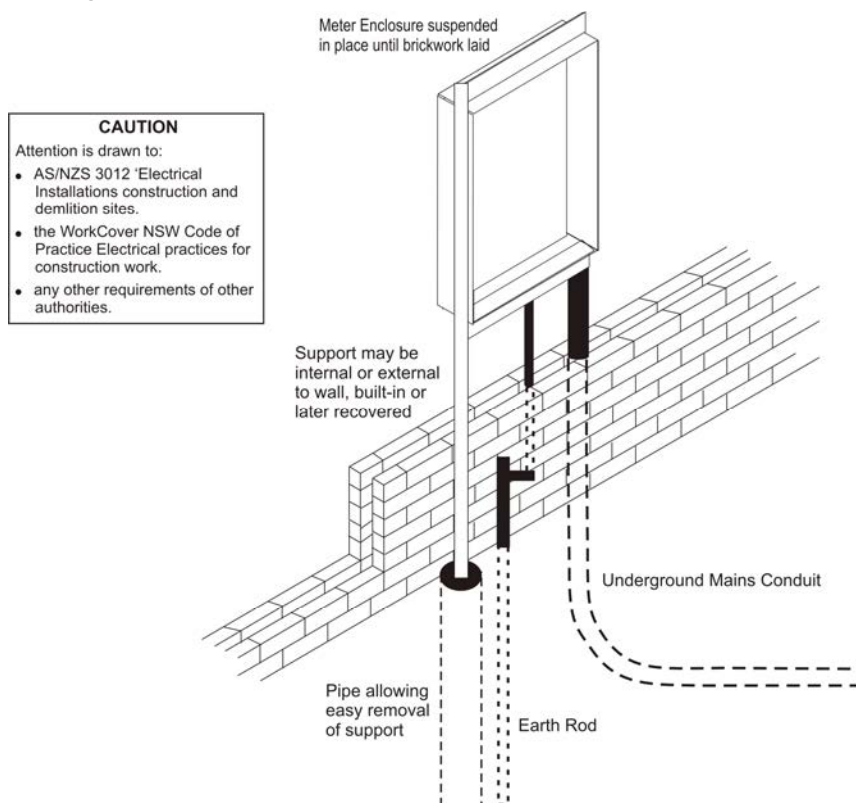

### Notes:

1. Install a permanent main earth conductor and electrode.
2. Adequate protection against mechanical damage during the construction phase, in particular to the underground service / consumers' mains, main earthing conductor and earthing electrode to be provided.
3. The construction uses electrical installation to comply with applicable codes and legislation.
4. Adequate protection for flexible cords entering the meter enclosure to be provided. Flexible cords must be protected from mechanical damage caused by the meter enclosure door.

## 2.10 Underground Supply from an Overhead Distribution System (UGOH)

### 2.10.1 UGOH

A Customer may request supply by way of an underground service from the overhead distribution system. This will be provided by an underground to overhead connection (UGOH) at the nearest electricity distributor pole. The following conditions apply:

- (a) The arrangement must not require any additional street pole.
- (b) The electricity distributor may inspect the site before agreeing to the proposal.
- (c) In footpaths, the conduit must be parallel to the property line and within the electricity distributor's easement or allocation, or at right angles to the property boundary.

### 2.10.2 Installation on the Electricity Distributor's Pole for an Underground Service with conductors up to a maximum 70mm<sup>2</sup>

The method of installation on the electricity distributor's pole for an underground service with conductors up to a maximum of 70mm<sup>2</sup>, must meet the following requirements (refer to Figure 2.9 for details).

- (a) The underground service cable must be installed in flexible plain conduit to AS 2053 'Conduits and fitting for electrical installations - Part 4 Flexible plain conduits and fittings of insulating material'.
- (b) Where the accredited service provider is not authorised as Category 3, the conduit and cable on the pole must be left coiled 3000mm above ground level.
- (c) The flexible conduit must extend a minimum of 1000mm underground from the base of the pole, and be protected against mechanical damage.
- (d) The conduit on the pole must be protected against mechanical damage up to 2500mm above and 300mm below finished ground level. The protection must be a close fit, tubular or "U" section construction with no side flanges (side-securing tabs are permitted). This is to minimise the surface area of the pole that is covered and help prevent climbing. Timber is unacceptable. Refer Figure 2.9.
- (e) Where fabricated metal enclosures are used to provide mechanical protection, they must be hot dipped galvanised to meet the specifications in AS 4534, 4680 and 4792.

- (f) Where the electricity distributor's pole on which the underground service is attached supports a high voltage earthing conductor or high voltage equipment that is earthed, all mechanical protection for the service cable is to be of non-metallic material. Specific (non-conductive) material is available.
- (g) The underground service must be installed to comply with the requirements of this document.
- (h) The amount of flexible plain conduit left coiled on the pole must be sufficient to reach the crossarm and enable a weather loop to be formed adjacent to the PCC. Allow for 1500mm of cable to be free of the conduit at the PCC to enable connection to the distribution system. Refer to Figure 2.9.

### 2.10.3 Installation on the Electricity Distributor's Pole for an Underground Service with conductors larger than 70mm<sup>2</sup>

Where an underground service cable comprises conductors larger than 70mm<sup>2</sup> the cables must be installed in accordance with the distributor's construction/approved materials inventory and installation method. Refer to Figure 2.10.

### 2.10.4 Maximum Number and Location of Underground Services that can be installed on an Electricity Distributor's Pole

The number of underground to overhead services that may be attached to the electricity distributor's pole is limited to the numbers shown in Table 2.3.

Cable attached to the side of a pole for the purpose of connecting aerial construction to underground construction or earth, with the exception of cables used to earth the electricity distributor's equipment, is considered an underground to overhead service. This includes all telecommunication cabling.

Where there is a requirement to put more than the permitted number of underground services on one pole, the electricity distributor will provide an underground pillar/pit in the footway allotment for the connection of additional underground service cables.



This is carried out at a cost to the customer requiring the last connection, or the connection that exceeded the permitted number of underground services on the electricity distributor's pole.

This cost is equal to the additional cost that this customer would have had to pay to extend the underground service onto the pole.

Additional underground services, where required, will be connected to the pillar/pit.

### 2.10.5 Underground Supply from Overhead Reticulation

Street poles on which distribution transformers, air break switches or similar equipment are mounted, or poles belonging to other statutory authorities (eg Telstra), will not be used except as a last resort. The electricity distributor must agree to this. New street (lead-in) poles must not be erected for underground services. An existing lead-in pole may be used for an underground service if there is at least one other service or attachment (including streetlight or other utility service) currently attached to the lead-in pole.

**Table 2.3: Maximum Number of Underground to Overhead (UGOH) Service Cables allowed on an Electricity Distributor's Pole**

Total Number of All Types of Existing UGOH's on the Distributor's Pole (Refer to Clause 2.10.4)	Additional Number of Customer UGOHs that can be placed on a Electricity Distributor's Pole			
	Conductors up to a maximum of 70mm <sup>2</sup>			Conductors greater than 70mm <sup>2</sup>
	Line pole	Transformer pole	Air Break switch pole	All situations
0	3	1	1	1
1	2	#	#	#
2	1	*	*	
3	*			

\* The customer must apply to have a UGOH installed to a pillar in the footway.

# One additional UGOH may be installed provided one is not connected to the LV mains, eg HV or telecommunications.

**Figure 2.8: Example of locating the Connection Point when the Point of Common Coupling is located on the customers' property and the underground service exceeds 50 metres in length.**

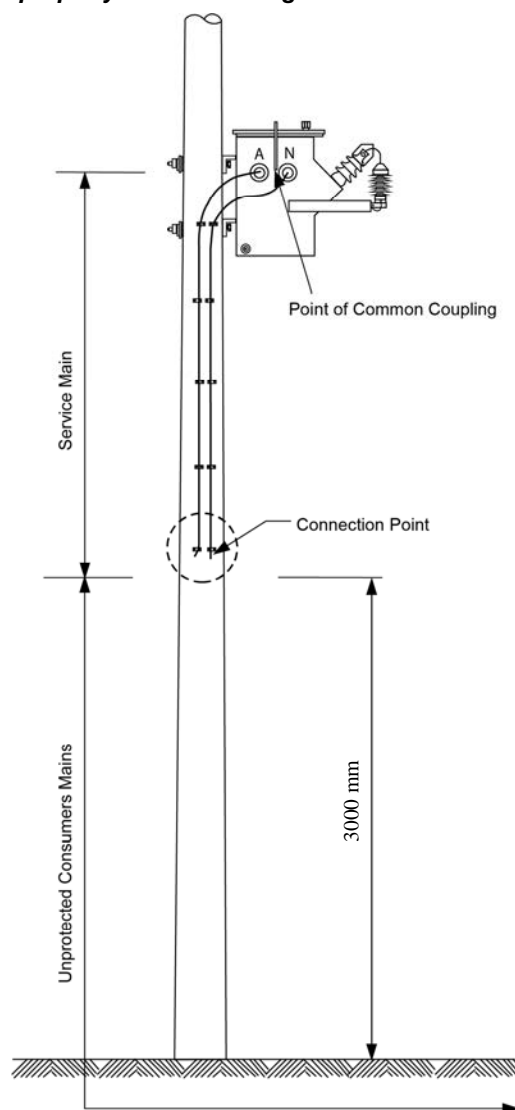

**Notes:**

1. This situation only applies when the Point of Common Coupling is located on the customers' property and where the underground service would exceed 50 metres in length.
2. Where the Point of Common Coupling is nominated on a transformer pole (as shown) the distribution system (deemed a service main for indicative purposes) forms part of the electricity distributor's standard construction and must be completed by an authorised Level 1 accredited service provider.
3. Where the Point of Common Coupling is nominated on a transformer pole with a LV isolation/protection device the Point of Common Coupling will be on the load side of that device.
4. Where the connection point is nominated on a transformer pole on relevant land non-Authorised persons cannot undertake the installation or connection of consumer mains above 3 metres from ground level.
5. Where the Point of Common Coupling is established on a pole other than a transformer pole, the underground service component will extend and terminate at the low voltage overhead distribution system. Category 3 (overhead) service providers must complete the work above 3 metres from ground level.
6. The installation method for the unprotected consumers mains on the electricity distributor's pole is to be in the same fashion as described in Figure 2.9 and 2.10 (an electrical contractor can carry out this work).
7. The installation and subsequent termination of the consumers mains on the electricity distributor's pole above 3 metres must only be completed by an authorised Level 2 (overhead) accredited service provider.
8. In this example, the Connection Point will be located on the pole, 3 metres above finished ground level.
9. To account for variations, connection method to be as nominated by the electricity distributor.

**Figure 2.9: Typical Underground Service with conductors up to a maximum of 70 mm<sup>2</sup> installed on an Electricity Distributor's Pole. (Refer to Table 2.3)**

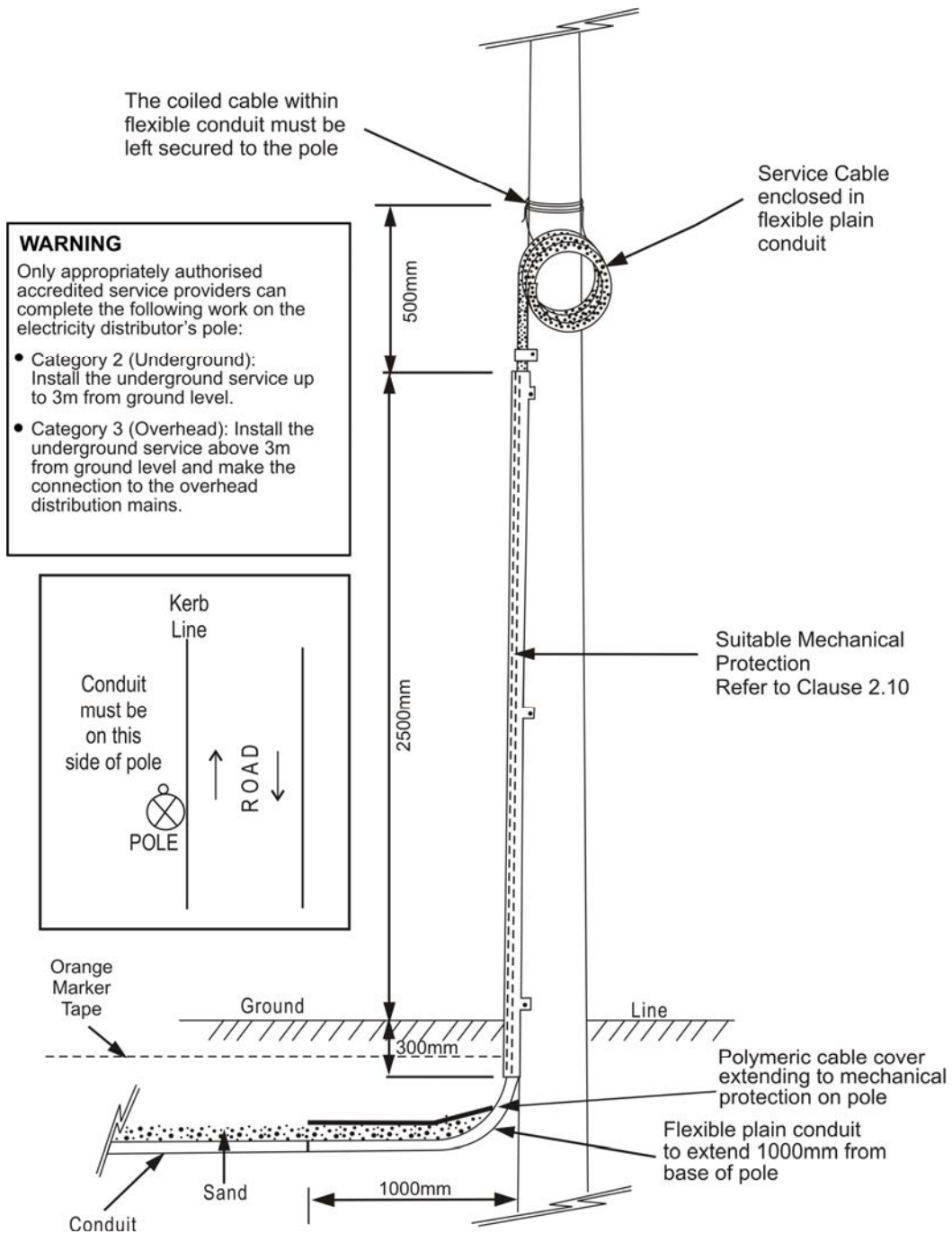

**Figure 2.10: Typical Underground Service with conductors larger than 70 mm<sup>2</sup> installed on an Electricity Distributor's Pole. (Refer to Table 2.3)**

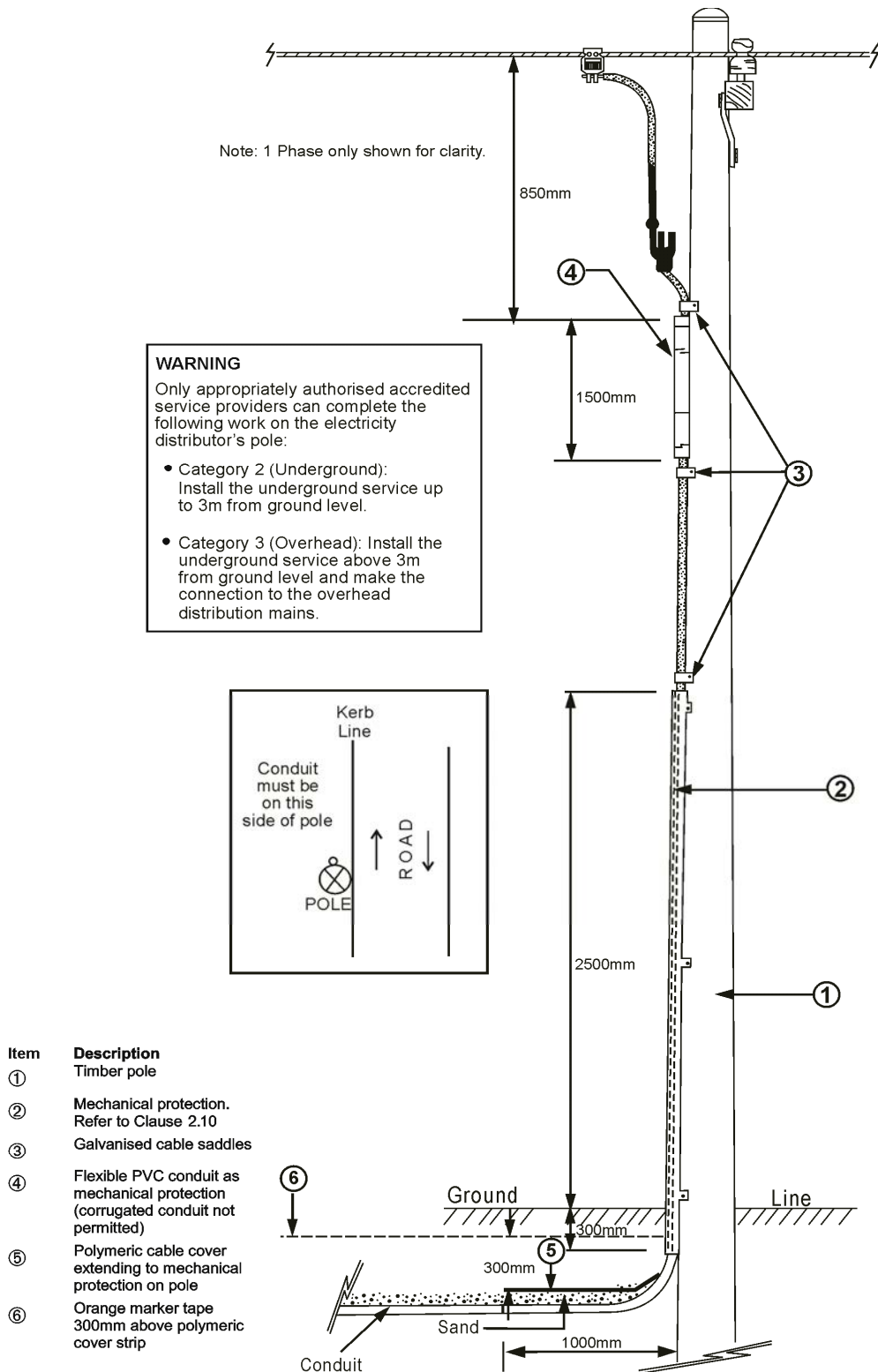

## 3 OVERHEAD SERVICES

### 3.1 Introduction

This Section outlines installation requirements for an overhead service rated at 100-400A.

#### 3.1.1 Approval for an Overhead Service

The electricity distributor may determine whether premises will be supplied by an overhead service. The electricity distributor must approve the:

- (a) Point of Common Coupling.
- (b) Type of construction.
- (c) Point of Attachment, and
- (d) Route of service.

Accredited Service Providers are qualified to determine whether an overhead service is required in accordance with the Distributor's requirements, however, to ensure bush fire risk management is addressed, Accredited Service Providers and electrical contractors should obtain electricity distributor requirements prior to installing overhead services in rural areas.

#### 3.1.2 Alternative to an Overhead Service

If a customer does not wish to take supply from an overhead service for any reason, an underground service may be provided (refer to Section 2) and the customer may be required to bear any additional costs incurred by the electricity distributor.

#### 3.1.3 Distributor's Street Poles

The electricity distributor will not erect a street pole to facilitate connection of the electrical installation to the electricity distributor's network unless, in the electricity distributor's opinion, no practical alternative is available.

#### 3.1.4 Specific Railway Requirements

Application in writing must be made to ST for the route, construction, and POA for an overhead service on railway land.

Special conditions apply which will be advised on application. Written approval from the party nominated in the ST publications is required for any proposed route.

#### 3.1.5 Existing Service – Alterations and Additions

This clause outlines the requirements for alteration and addition by or for the customer of any of the following:

- (a) Overhead service (clause 1.11.11).
- (b) Point of Attachment.
- (c) Consumers mains (including aerial consumers mains).

Table 3.1 summarises these requirements for the most common alterations and additions and the customer is required to fund the work unless otherwise stated.

Note: Only accredited service providers are permitted to perform the overhead service work outlined in Table 3.1.

The requirements should be confirmed with the electricity distributor if doubt exists (before commencing work).

#### 3.1.6 Retaining an Existing Service

Where work is being carried out, and it is proposed to retain the existing overhead service cables or a property crossing (see Table 3.1), all of the following provisions must apply:

- (a) The service cable and its associated fittings must be in good condition.
- (b) The service cable must be PVC or XLPE insulated.
- (c) All other aspects of the installation must comply with the Service and Installation Rules of NSW, i.e. access to and height of the POA, service clearances, etc.

Note: In certain instances (refer to Table 3.1) the electricity distributor as part of its maintenance responsibility will fund the replacement of the service line where conditions (a) and (b) above are not satisfied. The customer must fund any work required to satisfy condition (c) above.

The customer should make arrangements with the electricity distributor to replace the service cable (where the electricity distributor has agreed to fund the new service) in conjunction with the alterations or additions. Where the electricity distributor carries out this work the customer will be required to pay for the cost of the disconnection and reconnection (of the new service cable) at the connection point.

Alternatively, an accredited Service Provider (Level 2, Category 3 – Overhead) can complete this service replacement work. The electricity distributor will not reimburse accredited service providers for this work.

#### 3.1.7 Non-Distributor Pole Use

Non-distributor poles such as communications poles should not be used without prior consultation with the pole owner and distributor. See Clause 2.10.5.

**Table 3.1: Requirements of clause 3.1.5 for existing overhead services and consumers mains (100 - 400A) affected by alterations or additions**

Nature of the Alterations or Additions	Service Cable Requirements	Consumers Mains Requirements
Upgrading the consumers mains (cable being replaced)	Install as new if cable rating exceeded. If rating satisfactory apply clause 3.1.5 to determine need for replacement.	Install as new
Repairing the <i>consumers mains</i>	N/A	Repair as existing
Altering/relocating the Point of Attachment	Install as new if service needs to be extended	Install as new if cable rating exceeded
Increasing the number of phases (additional service cable required).	The service must now comply with these Rules	Install as new if cable rating exceeded
Increasing the number of phases (no additional service cable required).	Refer to Clause 3.1.5	Install as new if cable rating exceeded
Upgrading the service (cable being replaced)	Install as new	Install as new if cable rating exceeded
Re-routing a cross-property service line	Install as new	Install as new if cable rating exceeded

Note: Unless otherwise stated the customer must fund this work.

Reference to 'as new' means the final installation must comply with the current requirements of the Service and Installation Rules of NSW and AS/NZS 3000 as applicable.

Note: 100A service cables must not be paralleled to form 200A or greater. Existing 6mm<sup>2</sup> PVC insulated service cable has a rating of 70A/conductor.

## 3.2 Service Route and Point of Attachment

### 3.2.1 Special Overhead Considerations

The following factors should be taken into consideration:

- The location of the electricity distributor's poles in the street supplying adjacent properties.
- A transformer located on the pole selected for the connection of a service.
- The position, including its height above ground, of the POA.
- The existence of trees and large shrubs.
- Required clearances.
- The location of any additional pole.
- The selection of the POA to ensure that the route of the service is clear of swimming pools, vegetation and other relevant building features such as doors, windows, balconies and entrances.
- The location of other utility services, refer to clause 3.5.3.1.
- Mitigation of bush fire risks in accordance with the electricity distributor's Bush Fire Risk Management Plan and Procedures.

Connections are generally not permitted at pole substations in urban areas unless no practical alternative exists. The electricity distributor must approve the proposed connection in advance.

To ensure bush fire risk management is addressed Accredited Service Providers and electrical contractors should obtain electricity distributor requirements prior to installing overhead services in rural areas.

### 3.2.2 Service Route, Point of Attachment and Phase Selection

Single-phase customers should be connected to the following phase arrangement:

- Reconnect existing service cable to the same phase as previously connected, or
- Connect the new overhead service cable as listed in Table 3.2.

**Table 3.2: Phase Selection**

For lot or street number ending in:	Connect to:
1	A phase
2	B phase
3	C phase
4	A phase
5	B phase
6	C phase
7	A phase
8	B phase
9	C phase
10	A phase
20	B phase
30	C phase

### 3.2.3 Phase Selection for Single Phase Controlled Loads, supplied from a 3 Phase Service

Where a single-phase controlled load (e.g. off peak hot water system) is installed on a premises supplied from a three-phase service, apply Table 3.2 for the connection of the single-phase controlled load.

### 3.2.4 Crossing of Adjoining Property

A route crossing an adjoining property is only acceptable provided a suitable easement is obtained over the property. The only acceptable methods to prevent crossing of private properties are:

- (a) A post/pole erected by the customer on the customer's property in accordance with clause 3.7. The connection point will be at the post/pole.
- (b) Where approved by the electricity distributor's construction standards a suspended service (or mid span suspended service from ABC mains) not exceeding 100A, may be used where:
  - i) The customer's property is on the same side of the street as the distribution system.
  - ii) The distance between the line poles does not exceed 45m.
  - iii) The suspended service line at 90° to the mains does not exceed 20m (longer distances may be approved by the electricity distributor).

- iv) Written application for each individual installation must be submitted to the distributor.

A private pole should be installed to avoid a suspended service. A mid span/suspended service is only permitted as a last resort. Unusual building and distribution pole locations may warrant a suspended service which should be discussed with the distributor.

The electricity distributor will not consider the installation of a distribution pole unless there is no practical alternative.

**Note:** If a customer is required to relocate an existing cross property overhead service, that is not installed with an easement, the customer is responsible for the associated cost.

### 3.2.5 Crossing of Swimming Pool Zones

An overhead service or unprotected aerial consumers mains must not cross a swimming pool zone as defined by AS/NZS 3000.

### 3.2.6 Details of Service Route

When notifying the electricity distributor of completed works, the accredited service provider must supply details of the service including a sketch of the route. The Notification of Service Work (NOSW) form to be submitted to the electricity distributor provides a means of supplying this information. Refer to Figure 3.1 for a typical sketch and see clause 1.14 for NOSW requirements.

**Figure 3.1: Typical sketch of an 'As Constructed' Overhead Service from the Distributor's pole to the Connection Point**

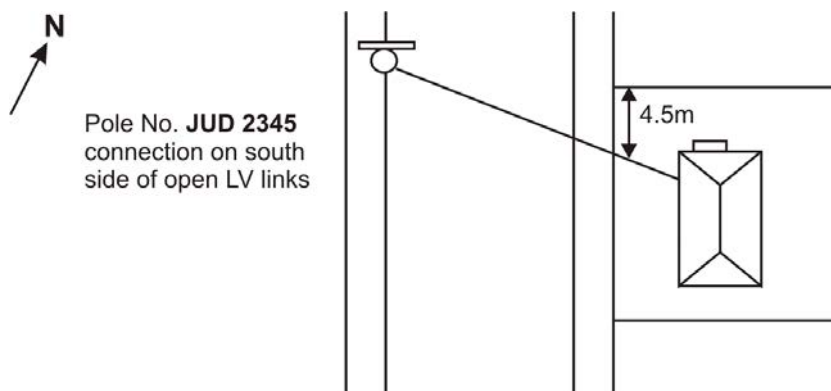

**Note:** The following details must be included in the sketch:

1. Pole number and if the pole has an LV open point (links) which side of the links the service connection was made
2. Distance between the point where the service crosses the front boundary and the nearest side boundary of the customer's property.

## 3.3 Aerial Consumers Mains

### 3.3.1 Electrically Un-Protected Consumer Mains

#### 3.3.1.1 General

Electrically Unprotected aerial consumers mains must comply with the same requirements as the overhead service with regard to cable size and compliance with the Australian Standards referred to in clause 3.4.

Where the connection point is nominated on a transformer pole on relevant land non-Authorised persons cannot undertake the installation or connection of consumer mains above 3 meters from ground level.

#### 3.3.1.2 Other than Aerial

Electrically Unprotected consumers mains must have a minimum cross sectional area of 16mm<sup>2</sup> Cu or 25mm<sup>2</sup> Al, XLPE insulated.

#### 3.3.1.3 Alterations and Additions

Alterations or additions to existing consumers mains must be treated as a new installation as per clause 1.11.11. This need not be applied where additional phase conductors are added to existing electrically unprotected single-phase consumers mains provided the cross-sectional area of the additional conductors is not smaller than the existing conductors.

#### 3.3.1.4 Bush Fire Precautions

Electrically Unprotected aerial consumers mains must be installed with regard to mitigation of bush fire risks in areas defined as bush fire areas by the Rural Fire Service and

the electricity distributor's Safety Management System and procedures and in accordance with AS/NZS 3000. To ensure bush fire risk management is addressed Accredited Service Providers and electrical contractors should obtain electricity distributor requirements prior to installing overhead consumers mains in rural areas.

### 3.3.2 Electrically Protected Consumers Mains

Electrically protected aerial consumers mains must comply with the requirements of AS/NZS 3000 or AS / NZS 7000: Overhead line design – Detailed procedures.

### 3.3.3 Maintenance

The Electricity Supply (Safety and Network Management) Regulation 2014 requires NSW electricity distributors to have a Safety Management System in place covering the management of bush fire risk relating to electricity lines including electrical installations of customers connected to the network.

Further, in accordance with the Electricity Supply Act 1995, in bush fire prone areas, distributors may require customers to rectify defective installations including vegetation management. Where such work is not carried out, distributors may carry out this work at the customers cost or alternately may disconnect an unsafe installation.

## 3.4 Cable Requirements

### 3.4.1 Minimum Requirements

The minimum requirements for overhead service cable are:

- (a) Compliance with AS/NZS 3560.1 Electric cables - 'XLPE insulated-aerial bundled - For working voltages up to an including 0.6/1kV'.

If these requirements are incompatible with the electricity distributor's distribution system design standards the electricity distributor will specify the conductor size.

Table 3.3 specifies the only service cables that may be used for various service ratings. Any intermediate service ratings (based on the assessed demand of the installation) must use the next largest service rating/cable available, eg a 350 Amp assessed service rating must use 2 x 95mm<sup>2</sup> Al 4-core cables (ie a 400 Amp service).

**Table 3.3 Service cable sizes and ratings**

Cable CSA (mm <sup>2</sup> )	Conductor Material	Cable Cores	Service Rating (Amps)
25	Al	1 twin or 4 core	100
95	Al	1 x 4 core	200
2 x 95	Al	2 x 4 core	400

Note: Prior to carrying out work at the POA contact the accredited service provider installing the overhead service to ascertain the cable type and configuration to be used.

### 3.4.2 Existing Overhead Service Cable Ratings

When a customer applies for the connection of additional loads the existing overhead service must be replaced where the assessed maximum demand will exceed its current carrying capacity. Overhead services less than (6mm<sup>2</sup>) must always be replaced. Refer to clause 3.1.6 regarding retention of an existing service.



## 3.5 Spans, Tensions and Clearances

### 3.5.1 Maximum Span

The maximum span for an overhead service up to 100A is 50m. For a service greater than 100A the maximum span is 30m. The electricity distributor may consider spans exceeding these distances when requested.

### 3.5.2 Tensions

The tensions of overhead services are set out in Table 3.8.

Where the requirements set out in this document do not meet the site criteria, a suitable structure and its mounting may be designed. It must be certified by a structural engineer using the information in Table 3.7 and other publications (e.g. AS/NZS 7000:2010–Overhead line design – Detailed procedures).

### 3.5.3 Clearances from Structures, Vegetation and Ground

Maintain minimum clearances above ground, and from trees, shrubs and structures, when calculating the height of the supports required for the service. Minimum clearances depend on:

- (a) Whether the ground under the service is likely to be used by vehicular traffic.

- (b) The nature of any nearby structure.

- (c) Trees and shrubs. Make adequate allowance for growth and the effect of wind. Minimum clearances are determined in accordance with ISSC 3: Guide to managing Vegetation near powerlines but in no case will be less than 1.5m from bare conductors and 0.5m from insulated conductors.

The required clearances from structures and ground are set out in Table 3.4 and illustrated in Figures 3.2, 3.3 and 3.4.

Allow for any proposal to change the ground level or build a structure along the route of the overhead service. Overhead services must not be installed where the required clearances are not obtainable at the time of installation.

The take-off from the electricity distributor's pole for the overhead service will be in the vicinity of the low voltage crossarm. The height of the crossarm varies between 6.7 and 8 metres.

When selecting the POA and route of the overhead service, allow for:

- (d) The maximum sag when determining the final ground clearance, and
- (e) The swing of conductors for clearance to structures.

Figure 3.2: Typical Clearance Situations - Elevation

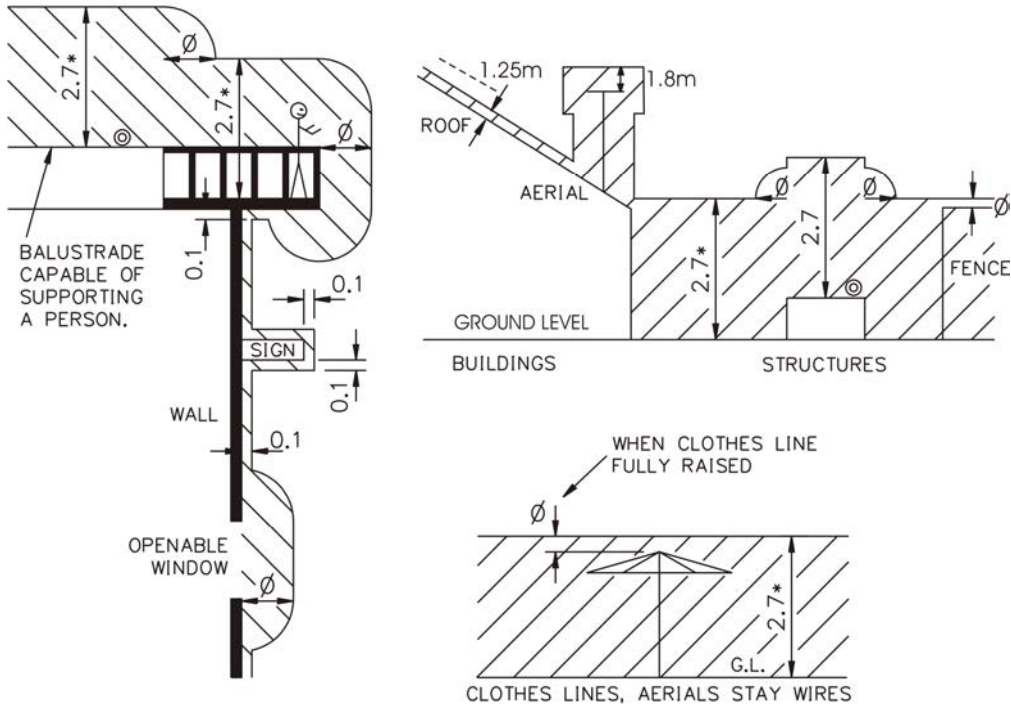

Note: These clearances must be achieved under all conditions (refer to Note 3 of Table 3.3)  
 ∅ 'Out of normal reach' = 1.25m (refer to Note 4 of Table 3.3).  
 \* Not used by vehicles  
 ⊙ Surface

Figure 3.3: Typical Clearance Situations - Plan

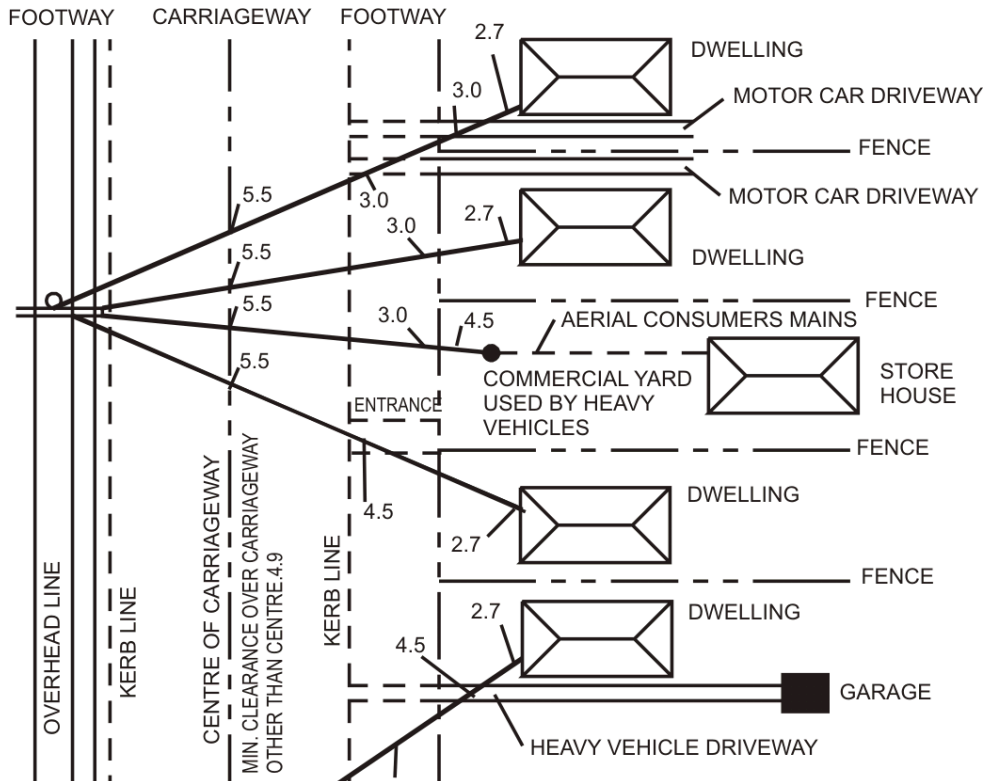

Note: These clearances must be achieved under all conditions (refer to Note 3 of Table 3.4)

**Table 3.4: Minimum Clearances to Insulated Overhead Service**

From the insulated service conductors to the surface of:		Minimum clearances (metres)
1	Any part of a freeway or arterial road	5.5 vertically
2	The centre of a carriageway of a public road	5.5 vertically
3	Any part of a carriageway of a public road (other than the centre)	4.9 vertically
4	Vehicular crossing of a footway in a public road (other than a residential driveway)	4.5 vertically
5	Vehicular crossing of a footway in a public road for a residential driveway and any other part of a footway	3.0 vertically
6	Land which is not associated with a dwelling and which is likely to be used by vehicles, including non-urban small acreages and hobby farms	4.5 vertically
7	Land which is, or is likely to be used by vehicles and is associated with a dwelling	3.0 vertically
8	Land not likely to be used by vehicles	2.7 vertically
9	Those parts of any structure normally accessible to persons. (See Note 1)	2.7 vertically
10	Any area above a roof	1.25 metres
11	Any area around a radio or TV aerial	1.8
12	Those parts of any structure not normally accessible to persons. (See Note 2) (including below a projecting slab, balcony or sign)	0.1 in any direction
13	The edge of any opening window, balcony, verandah, clothes line or fence etc	Out of normal reach (see Note 4)
14	Point of Attachment	3m vertically not normally accessible without a ladder or other device (see Notes 1-4)
15	Farmland where mechanical equipment is used	5.5 vertically
16	Trees and shrubs	0.5 in any direction
17	Vicinity of boat ramps, launching areas (avoid if possible)	10.0 vertically
18	Communications conductors	0.6 in any direction

**Notes:**

Interpret the requirements set out in Table 3.4 as follows:

1. **Structure Normally Accessible to Persons** includes:
  - (a) The whole area of any flat roof accessible without the use of a ladder.
  - (b) Any part of a hip or gable roof accessible without a ladder up to the nearest hip or gable.
  - (c) Any portion of a balustrade or other structure which will support a person and is accessible without a ladder.
2. **Not Normally Accessible to Persons** excludes roofs and includes any portion of a fence, balustrade, advertising sign or other structure which will not support a person or is not accessible without a ladder.
3. **The minimum clearances** in Table 3.4 must be achieved under all conditions regardless of:
  - (a) Conductor swing due to the influence of wind.
  - (b) Conductor sag due to the influence of load current and ambient temperature.

The requirements of Table 3.4 may be achieved if the maximum allowable service line sag for a particular conductor size and span is added to the minimum clearance. Refer to Table 3.8.
4. **Out of Normal Reach** means 1.25m from any normally accessible position. The requirement that an overhead service must be out of normal reach of persons may be achieved in some cases by the provision of a permanent insulated barrier (consult with the electricity distributor).

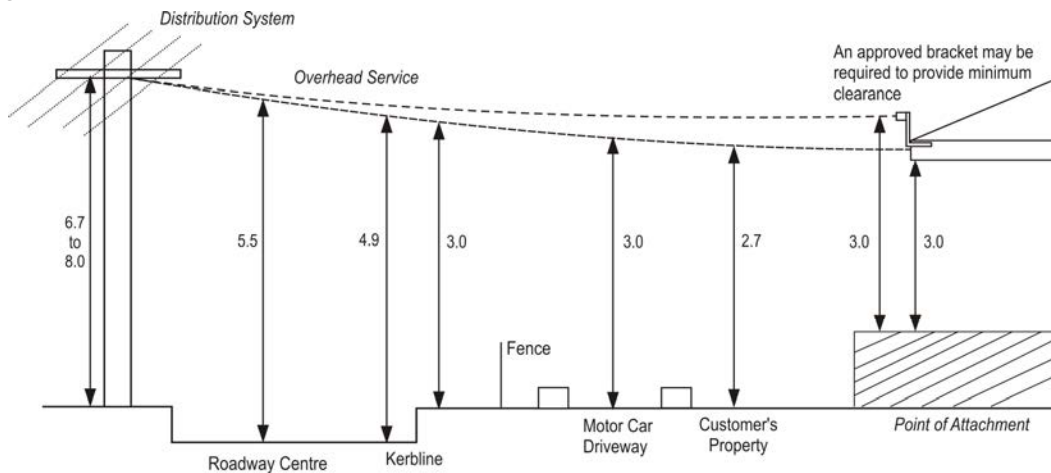
**Figure 3.4: Clearances to Overhead Service - Elevation**

Note: 1. These clearances must be achieved under all conditions (refer to Note 3 of Table 3.4)

The Point of Attachment is to be 3m minimum above the ground, floor or platform level.

### 3.5.3.1 Clearances to other Utility Services

The accredited service provider is responsible for obtaining the required minimum clearance of 600mm between the proposed overhead service and conductive aerial communications cables.

Note: Alternative arrangements for non-conductive communications cables may apply.

### 3.5.3.2 Searches for Underground Utility Services

Contractors must carry out a search for underground utility services, prior to excavating for private poles, etc. Adequate clearances must be obtained between private poles and underground utility services. Check with the appropriate utility to determine any required clearances.

Initial search information can be obtained from Dial Before You Dig.

Utilities may include:

- water
- sewer
- drainage
- gas
- communication cables

- power cables
- railway power, signalling and communication cables (which as well as being located on railway land can be located in public streets, parks, etc).

#### Dial Before You Dig

Phone 1100 - free call (except from mobiles)

Website [www.1100.com.au](http://www.1100.com.au)

Australia's major service providers have made available a single web-enabled information service for information on the location of underground communications, gas, water and electricity infrastructure. Use the website ensure that you 'Dial Before You Dig' before any excavation. If calling, be ready to provide the operator with:

- name and address
- name of company
- contact telephone number
- fax number for return information
- contact name on site
- site address and both nearest cross streets
- start date of proposed work
- type of work being carried out

## 3.6 Access to Service and Point of Attachment

The overhead service and POA must be erected with readily available access. The area below the POA should provide a firm, level base with sufficient space to safely erect a standard 4m/7m extension ladder. A space for the ladder 1m square with the centre of the space 1.5m from the base of the POA is satisfactory.

Unacceptable access to a POA examples are:

- (a) Access using a second ladder, except where the POA is above a shop or commercial building's awning.
- (b) Resting a ladder against the balustrade of a balcony to get access to a POA.

- (c) Access to the POA by walking upon a building or verandah roofs.
- (d) Access through a building. Exterior stairs may be used to gain access to a balcony.
- (e) Access from adjacent private property.

The POA must not be accessible without the use of a ladder or other device to assist climbing. If necessary, install a protective guard to prevent unauthorised access. When access is from an awning or balcony, its construction should allow safe working practices to be followed in attaching an overhead service to the building.

---

## 3.7 Facilities to be Provided by the Customer

### 3.7.1 Point of Attachment

The POA must be located on the aspect of the building facing the distribution mains, or on a customer pole or other structure accessible to the distribution system.

The POA must be selected to prevent the crossing of adjoining properties. Refer to clause 3.2.4.

The overhead service support structures must be able to withstand the tensions listed in Table 3.8.

The minimum height of the POA fixing is 3m, the maximum height on a building or structure is 6.7m above ground. Figure 3.5 illustrates the minimum height at the POA. The unsuitable areas for a POA are shown in Figure 3.6.

**Figure 3.5: Typical Points of Attachment - Elevation**

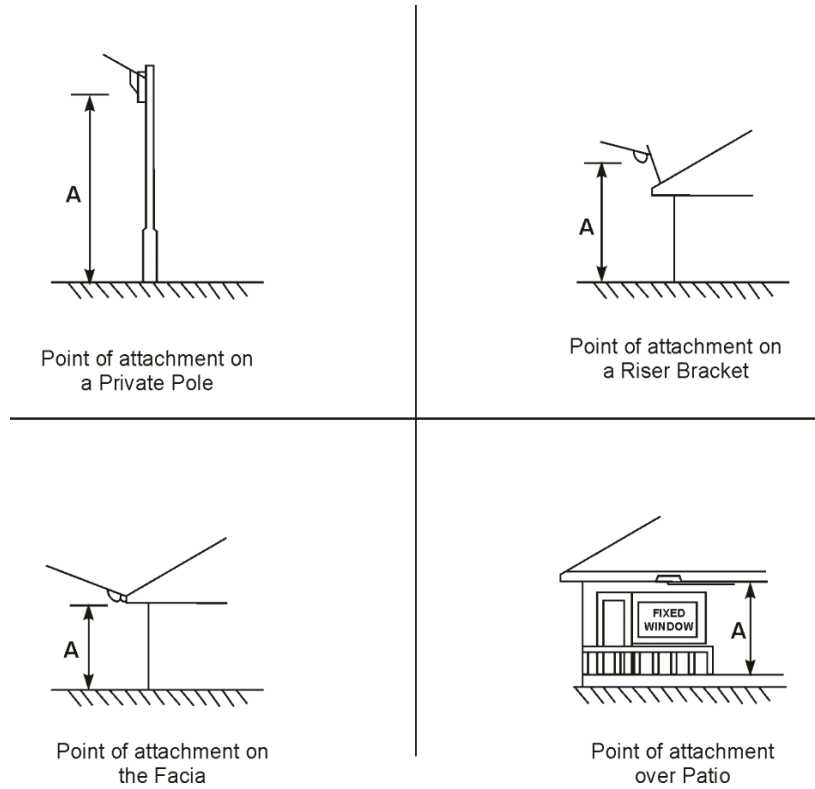

**A = 2.7m - minimum height to the bottom of the drip loop**

Note: The minimum height of the Point of Attachment is 3m.

**Figure 3.6: Unsuitable Points of Attachment shown shaded**

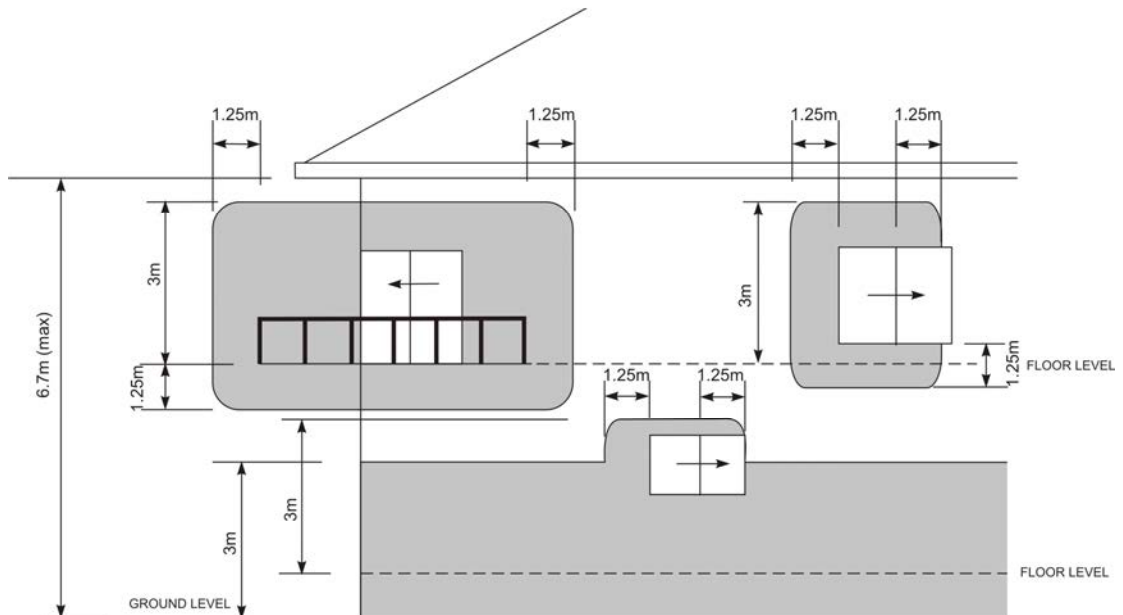

Note: The *Point of Attachment* should not be located in the shaded areas as shown above.

### 3.7.2 Private Post/Pole

Where a private post/pole is to be installed, it must be sized and located to avoid the use of an additional electricity distributor's pole in the street. The circumstances which may require the installation of an additional post/pole are set out as follows.

Note: The overhead service terminates at the connection point. This is the first support on the customer's premise. Refer to Figure 1.1.

#### 3.7.2.1 Private Posts/Poles

Private posts/poles are to be erected in any of the following circumstances:

- As an alternative to a road crossing pole, which would otherwise be necessary to be used, to maintain clearance requirements for the overhead service crossing the road.
- The customer wishes to install underground consumers mains within the premises (a sketch of the route of the underground consumers mains should be provided in accordance with Section 2).
- No suitable POA is available on the building.
- The crossing of adjacent premises has to be avoided and a suspended service (where permitted by the electricity distributor) is not practicable.
- The span would be excessive due to the distance from the electricity distributor's pole to the building. Spans exceeding the distances set out in clause 3.5.1 are regarded as excessive.
- To provide required clearances.
- To provide supply to a battle-axe block.

A private post/pole must be installed within 1 metre of the front property street alignment.

#### 3.7.2.2 Labelling of Private Post/Pole

A customer's pole must be clearly labelled to indicate 'PRIVATE POLE' to differentiate it from the electricity distributor and other utility poles. Lettering must be a minimum 20mm high.

#### 3.7.2.3 General Requirements

Customers may have to obtain approval from the local council before a post/pole is erected on the customer's premises.

Cross arms are not required on customer's posts/poles because the cables are supported using a single bolt per support. Open wire services must have the bolts separated by 250mm minimum.

If the POA on the customer's post/pole exceeds 6.7m in height, pole steps must be fitted to the pole. Pole steps must not be installed within 6m of ground level. They must have a rise not exceeding 450mm, be located on alternate sides and spaced with 120mm between them.

A post/pole supporting an overhead service and aerial consumers mains must comply with the requirements of both AS/NZS 3000 and these Service Rules. It should comply with the most onerous of these requirements.

Posts/poles must be securely set in the ground.

If the soil does not provide enough support, eg in built-up ground or soft soil, secure posts/poles either by setting them at a greater depth than normally required, or by using bearing blocks or shoes. Refer to Table 3.5 and its notes.

Where, because of unusual circumstances, the butt of the post/pole cannot be sunk to the required depth in the ground, an alternative construction, such as flange mounting on a reinforced concrete structure, may be accepted.

In all such cases, you must obtain a structural engineer's certification that the mounting has been designed to meet the requirements set out in clause 3.7.6 before construction may proceed.

The required length of the post/pole above ground must be assessed when selecting post/pole sizes to obtain necessary clearances.

Posts/poles must be set in the ground, as listed in Table 3.5, taking into account the soil quality as specified.

**Table 3.5: Sinking of Posts/Poles in Ground**

Free Length to Lowest	Depth In Ground (metres)		
	Poor Soil	Medium Soil	Good Soil
3.0	1.6	1.3	1
3.3	1.6	1.3	1
3.6	1.6	1.3	1
3.9	1.6	1.3	1
4.2	1.8	1.5	1.2
4.5	1.8	1.5	1.2
4.8	1.8	1.5	1.2
5.1	1.8	1.5	1.2
5.4	1.8	1.5	1.2
5.7	1.8	1.5	1.2
6.0	1.9	1.6	1.3
6.3	1.9	1.6	1.3
6.6	1.9	1.6	1.3
6.9	1.9	1.6	1.3
7.2	1.9	1.6	1.3

Notes:

#### 1. Free Length

The free length to the lowest conductor support shown in the Table is the distance between the lowest conductor support and ground level.

**2. Soil Quality**

Soil quality is defined according to AS/NZS 7000: Overhead line design – Detailed procedures.

- (a) Poor - Soft clay, poorly compacted sand and soils that tend to absorb large amounts of water (150kPa/m).
- (b) Medium - Compact medium clay, well bonded sandy loam, bonded sand and gravel with reasonable surface water drainage (300kPa/m).
- (c) Good - Well compacted rock soil, hard clay and well bonded sand and gravel with good surface water drainage (600kPa/m).

**3. Posts/Poles set in Concrete**

Where a post/pole is set in concrete:

- (a) It must be located centrally in a bore hole sized in accordance with Table 3.6.
- (b) The concrete should be finished not less than 300 mm below ground:
- (c) It is equivalent to improving the soil quality by one step, i.e. from poor to medium or from medium to good. This corresponds to a reduction in the required pole sinking depth.
- (d) It should be left undisturbed for three days, or long enough to ensure the concrete has developed adequate strength prior to attaching the overhead service.

**4. Posts/Poles set in Solid Rock**

Where a post/pole is set in solid rock, the depth in ground may be reduced by 0.3m.

**Table 3.6: Minimum Size Bore Holes for Posts/Poles**

Post/Pole Size	Post/Pole Material	Minimum Bore Hole Diameter
All sizes	Timber or Steel	Post/pole diameter plus 100mm

**3.7.2.4 Timber Posts/Poles**

Timber posts and poles must be of hardwood or other suitable timber as specified by AS3818.11 – 2009 Timber – Heavy structural products – Visually graded – Utility poles.

- (a) Tables 3.9 and 3.11 sets out the minimum sizes of timber posts or poles of untreated hardwood timber with durability of Class 1 and 2 and strength rating of S3 or better.
- (b) AS/NZS 3000 sets out the minimum sizes for preservative treated hardwood or softwood timbers with durability Class 4 or better and a strength grade S6 or better.

The base of timber posts/poles and surrounding ground must be treated against insect and fungal attack by environmentally approved methods.

Timber posts/poles must be capped at the top to prevent water penetration.

The distance between the top anchor bolt and the top of the post/pole must not be less than 200mm.

**3.7.2.5 Steel-pipe Posts/Poles**

The required sizes/grades of steel-pipe posts/poles are set out in Tables 3.15 to 3.18.

Steel-pipe posts/poles must be capped at the top to prevent water entry.

**3.7.2.6 Other Posts/Poles**

Posts / poles may be made from other suitable materials (eg reinforced concrete) provided adequate certification of strength and durability is provided for approval by the distributor.

**3.7.3 Attachments to Buildings or Structures**

**3.7.3.1 Responsibility for Design**

It is the customer’s responsibility to ensure that the support is designed and installed in accordance with sound engineering practice. It must be suitable for the direction of pull of the proposed or existing overhead service.

The distributor does not accept responsibility for damage to the customer’s premises resulting from normal tension in the overhead service or causes beyond the distributor’s control. If necessary the services of a structural engineer should be sought where doubt exists as to the strength of an attachment. AS/NZS 7000: Overhead line design – Detailed procedures. gives guidelines for the design of structures for the support of overhead services.

**3.7.3.2 Alternative to Attaching to a Building**

If a customer wishes to avoid attaching the overhead service to the building, this can generally be done by erecting a post/pole and installing underground consumers mains.

**3.7.3.3 Horizontal and Vertical Struts**

A strut is a straight length of support. Once it is bent, off-set or braced it is then classed as a bracket.

The sizes of horizontal and vertical struts are set out in Tables 3.10, 3.12, 3.13, 3.15 to 3.18. Timber or hollow steel struts must be capped at the top to prevent water penetration.

Note: The free length to the lowest conductor support shown in the Tables is the distance between the lowest conductor support and the closest fixing bolt on a structure (see Figure 3.7).

Two fixing bolts must be used at a minimum distance of 600mm apart to fix the strut to a structure.



**Figure 3.7: Typical Strut Mounting**

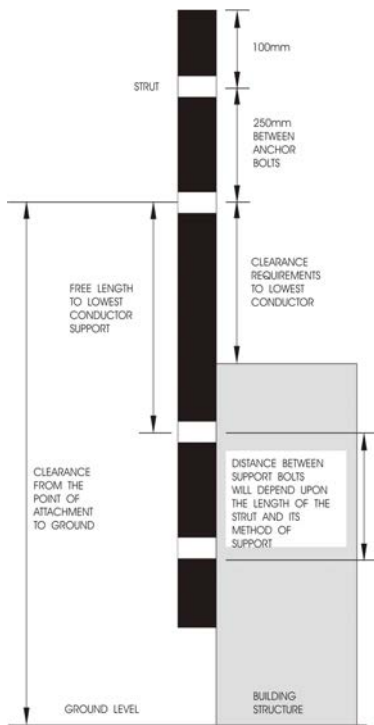

**3.7.3.4 Service Brackets**

For a 100A overhead service you may use an approved service bracket to obtain the required clearances, outlined in Table 3.4.

Service brackets must be fabricated from minimum grade 250 steel. Any joints must be welded. They must bear a manufacturer’s label indicating that they meet the requirements of this clause. Refer to Table 3.7.

**Choosing a bracket:** Refer to Figure 3.8 for description and Table 3.7 for strength.

An explanation of Table 3.7 follows:

**Bracket Rise:** The numbers 2 to 6 indicate the free length or rise in 150mm steps to 900mm. The rise of the bracket is the dimension from the centre line of the mounting bolts to the centre line of the lowest anchor bolt(s) for the overhead service.

**Number of Anchor Bolts and Hooks:** The last number in the bracket description indicates the number of 12mm anchor bolts provided for on the bracket to secure the overhead service. The customer provides the bolts. The bolts may be replaced with hooks, as illustrated in Figure 3.9, welded or bolted to the bracket.

**Strength Rating:** The symbols A, B and D are used to indicate strength. The design strengths for A, B and D brackets are 0.59, 1.18 and 2.1kN respectively. The design strengths provide for a factor of safety to meet the specifications in clause 3.7.6.

**Example:** A bracket having a classification 2B2 would have a free length of 300mm above its mounting point and provision for 2 bolts to anchor insulators. It would be suitable for a loading of up to 1.18kN. A 2D2 bracket would be similar in characteristics to the 2B2 but suitable for a loading of up to 2.1kN. It would therefore be an acceptable alternative where a 2B2 bracket is specified. Similarly a bracket having a higher rise than that specified is satisfactory.

**Table 3.7: Bracket Description**

Bracket Rise	Strength Rating	No. of Anchor Bolts and Hooks
2	A	1 or 2

Bracket Rises	mm
2	300
3	450
4	600
5	750
6	900

Bracket Strength Rating kN	
A	0.59
B	1.18
D	2.1

**Bracket Use**

1. If a bracket’s strength rating or rise is unavailable, use the next size up e.g., need a 2A1 bracket - use 2B1 or 3A1.
2. If allowing for future 3 phase, a higher strength is required with an additional anchor bolt, e.g. 1 phase 10m span needs a 2A1 - a 2 or 3 phase 10m span needs 2B2 therefore 2B2 needs to be installed initially. Refer to Table 3.8 for minimum bracket strength rating.
3. One hook or bolt on each bracket is required for each *overhead service*.

### 3.7.4 Protection against Corrosion

Where steel is used for posts, brackets, struts, hooks, hardware or fittings associated with an overhead service it must be galvanised to meet the specifications in AS 4534, 4680 and 4792.

The hot-dip process must be used. Small areas where the zinc coating has been removed must be replaced with a durable zinc rich coating.

**Figure 3.8: Service Bracket Installation Example**

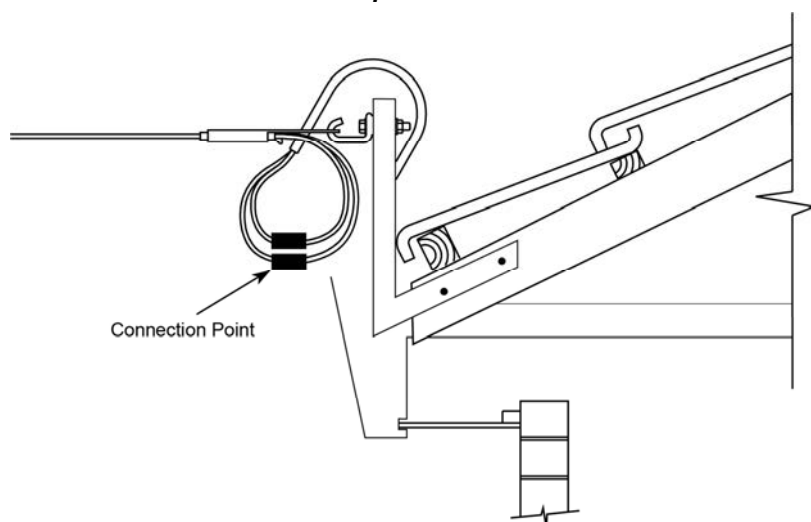

The distributor may approve alternative corrosion protection methods if suitable for the location.

### 3.7.5 Earthing Metallic Supports

Refer to AS/NZS 3000 for the earthing requirements of metallic supports for aerial service conductors (poles, service brackets, struts, hooks, fittings and attachments, etc).

### 3.7.6 Strength Requirements of Attachments and Supports

Overhead services are installed with an initial tension which will subsequently vary within normal limits.

The customer must secure anchor bolts, struts or service brackets in such a way that the load (refer to Table 3.8) is safely transmitted to a structurally adequate portion of the building.

The customer must ensure that the building or structure, and the means of fixing the anchor bolts or bracket to it, are at least sufficiently strong to take the normal tension of the overhead service, as indicated in Table 3.8.

#### 3.7.6.1 Fixing of Attachments and Supports on Buildings

Fix brackets to a structurally adequate part of the building using galvanised steel bolts at each fixing hole provided in the bracket. The bolt must be 12mm diameter except where brackets are fixed to a rafter in which case, 10mm diameter is satisfactory. Nailing of nogging between rafters, and attachment of the bracket to the nogging is not acceptable. Figure 3.8 shows a typical service bracket installation.

Do not attach a strut or service bracket to a brick or masonry wall unless the load on the mounting bolts is transferred to a structural member (unless otherwise approved by a structural engineer).

#### 3.7.6.2 Number and Size of Anchor Bolts

The customer's contractor must install the required number of galvanised steel anchor bolts or hooks to provide a secure POA for the overhead service. The following service line and anchor bolt arrangements are typical:

**100A service (single-phase)** - one twisted twin insulated cable and one 12mm diameter anchor bolt.

**100A service (two or three phase)** - one bundled four core insulated cable and one 12mm diameter anchor bolt.

Note: The 12mm anchor bolt may be replaced with a formed hook bolt or a hook welded to a metal structure. See clause 3.7.6.3, Figure 3.9 for details of 100A service hooks.

**200A service** - one bundled conductor cable and one 16mm diameter minimum anchor bolt.

**300/400A service** - two bundled conductor cables and two 16mm diameter minimum anchor bolts.

If the head of a bolt is not readily accessible, it must be securely fixed to prevent rotation. Bolts must have at least 25mm of thread projecting and be complete with finger-tight galvanised steel nuts.

Where more than one anchor bolt or hook is used, they must be spaced 250mm minimum, 400mm maximum vertically or horizontally.

### 3.7.6.3 Service Hook

The hook must be minimum 12mm diameter, grade 250 steel rod.

It must be formed into shape using a die without sharp edges and without using heat treatment.

The hook may be:

- (a) Welded to the metal structure so that the bond strength is not less than that of the rod.
- (b) Bolted to the structure using 12mm diameter bolts.
- (c) Threaded like a coach screw hook and screwed to an adequate structural member.

**Figure 3.9: 100A Service Hook**

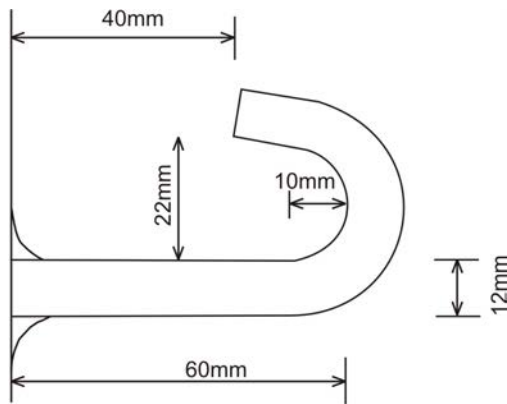

### 3.7.6.4 Fixing Anchor Bolts to Concrete and Brick Walls

Anchor bolts may be fixed to:

- (a) A reinforced concrete wall (at least 300mm from any opening).
- (b) A reinforced concrete slab provided the point of fixing is in the centre of the slab and at least 300mm from a corner.
- (c) Brick walls provided the load on the bolts is transferred off the wall to another structurally adequate portion of the building (unless otherwise approved by a structural engineer).

Note:

1. Wall plugs must not be used.
2. Expansion fittings must not be used in brick walls.
3. Chemically set bolts may be used provided the manufacturer's instructions are followed.

### 3.7.6.5 Stays

Struts and service brackets must rely on their fixing bolts for support. Secondary supports by way of a stay or brace are not permitted.

### 3.7.6.6 Abnormal Loading

In the event of a vehicle colliding with a pole in the street or a tree falling across the overhead service, the load imposed on the building may be as high as the total breaking strain of the conductors. This load is given in Table 3.8. The customer can either strengthen the structure to provide for this, or accept the risk of an accident occurring.

### 3.8 Builders Service

An overhead service may be installed for the purposes of building construction. A suitable meter box enclosure mounted on either a removable pole/post or on a post made up of two sections of timber bolted together (split post) is acceptable. Refer to clause 3.8.1 for details.

Post/pole sizes must comply with either Tables 3.9, 3.10 or 3.14 to 3.18, must be in good condition and inspected prior to each use by the contractor.

Refer to Figure 3.10 for typical installation details.

Refer to clause 3.7.2 for more detailed service post/pole requirements if relevant.

#### 3.8.1 Split-Posts

A split-post may be used for a builders' service installation supplied by a 100A overhead service, provided it is:

- (a) Fixed together with two 16mm diameter bolts and washers, 600mm apart, with a minimum of 150mm to the timber ends.
- (b) Of a minimum 150mm x 150mm cross-sectional area. The top of the ground portion is to be capped or chamfered.
- (c) Erected so that the lengths of the bolts are in line with the proposed direction of the service line and the base section sunk to the depth required for permanent posts.

Refer to Figure 3.10 for typical installation.

#### 3.8.2 Consumers Mains

The unprotected consumers mains associated with an overhead service on a builders service post/pole, may have a minimum size of 6mm<sup>2</sup> copper thermoplastic insulated and sheathed cable (maximum demand permitting) when installed in PVC flexible plain conduit to AS/NZS 2053 Part 4-1995 'Conduits and fittings for electrical installations Part 4: Flexible plain conduits and fittings of insulating material'.

---

### 3.9 Underground Supply from Overhead Distribution System (UGOH)

Refer to Section 2 - Underground Services.

Figure 3.10: Typical Builders Service

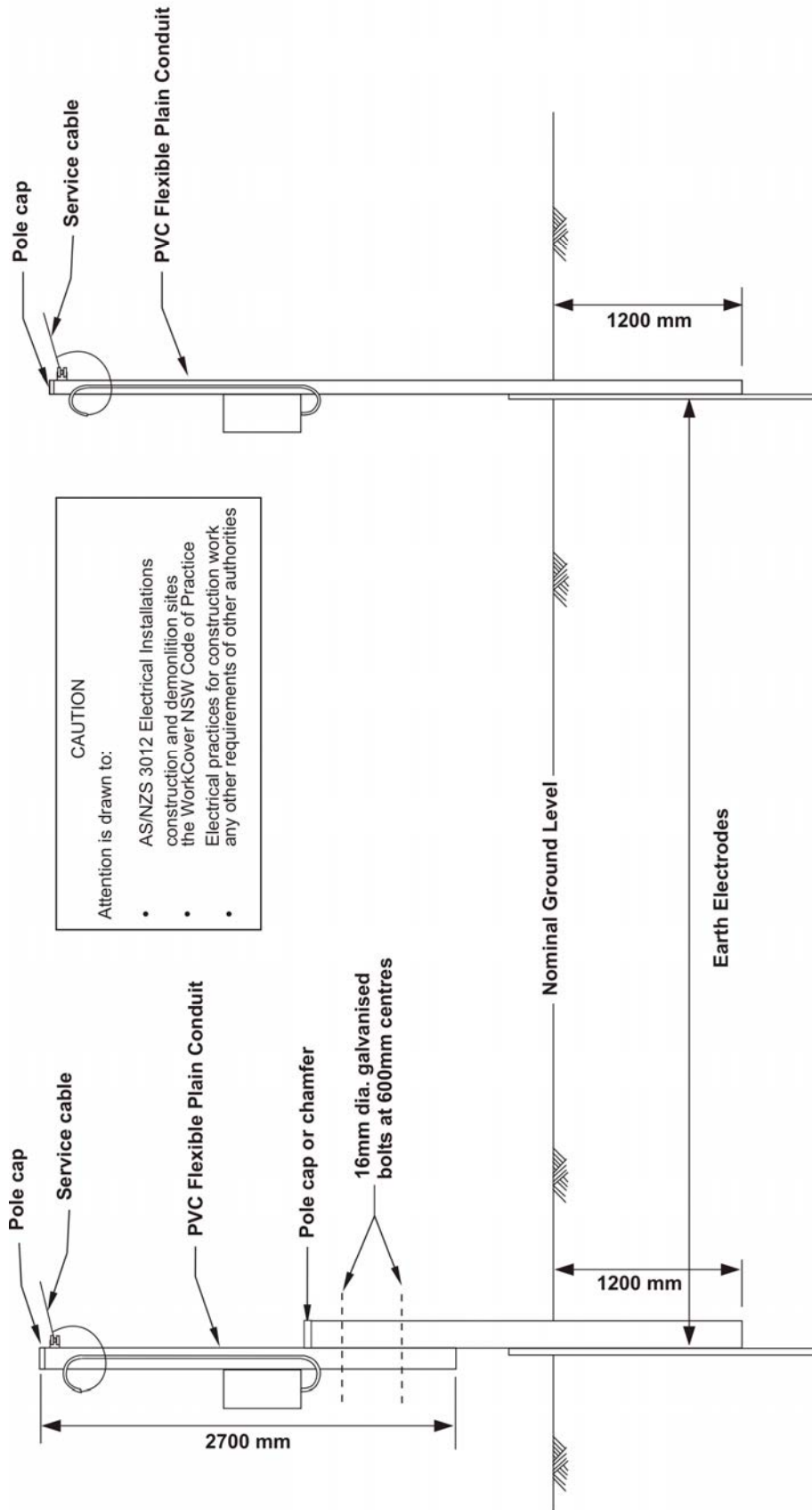

**Notes:**

1. Pole should be positioned to ensure adequate overhead service line clearances.
2. These installations are acceptable for underground distribution systems.
3. The electrical installation must comply with the AS/NZS 3000.
4. Unprotected consumers mains associated with an overhead service line on a builder's service post/pole, may have a minimum size of 6mm<sup>2</sup> copper (maximum demand permitting) when installed in PVC flexible plain conduit to AS 2053 Part 4 - 1995.

### 3.10 Minimum Sizes of Posts, Poles and Struts for Overhead Services

The following Tables specify the required sizes of conductor support structures. The Tables cover the standard overhead service conductors used in NSW. The conductor support structures covered are:

- (a) Timber posts and poles.
- (b) Square timber struts.
- (c) Angle iron struts.
- (d) Steel poles.
- (e) Steel square section.
- (f) Fabricated steel pole.

Table 3.8 gives the forces exerted by service lines. This is a function of:

- (g) The type of conductor being used.
- (h) The span length.
- (i) The design sag.

These factors combine to give the **normal tension of an overhead service in kN**. The last column of Table 3.8 indicates the minimum pole or strut strength required (S rating).

Using this strength rating refer to the following Tables 3.8 to 3.18 to select the appropriately sized post, pole or strut. Make sure the S rating selected from Tables 3.9 to 3.18 is equal or greater than the required S rating derived from Table 3.8.

Notes:

1. The free length to lowest conductor support shown in the tables is the distance between the lowest conductor support and:
  - i) the ground for a pole or post
  - ii) the closest fixing bolt on a structure for a strut.
2. Galvanised steel-pipe posts with outside diameters up to and including 165mm are Grade 250 - steel water pipe commercially available in 6.5m lengths. Posts specified with diameters of 168mm or greater are of Grade 350 structural steel circular hollow sections and may need to be specially ordered. The electricity distributor must assume that steel pipe posts, installed by contractors, are Grade 250, unless the contractor can substantiate otherwise.
3. Service spans above 30m for 1 x 95mm<sup>2</sup> or 2 x 95mm<sup>2</sup> (4 core LV ABC) must only be approved for connection to street mains, following an investigation by the electricity distributor. The tension of these overhead services, may damage the distribution system construction.
4. Any post/pole supporting an overhead service and aerial consumer mains must comply with the requirements of both AS/NZS 3000 and these Rules. It should comply with the most onerous of these requirements.

**EXAMPLE 1**

**Problem:**

Erect a 100A 3 phase service (using 1 x 25mm<sup>2</sup> Al 4 core LV ABC) a distance of 19 metres.

**What:**

- (a) Sag required for the span.
- (b) Height of conductor support to give clearances to ground or other structures.
- (c) Size structure is required.

**Solution:**

From Table 3.8

**Pick:**

- (a) 100A 3 phase from size of service column.
- (b) 1 x 25mm<sup>2</sup> Al from conductor size column.
- (c) 20m from span column.

**Table 3.8 gives:**

- (a) Normal tension of service line = 0.77 kN.
- (b) Maximum sag = 0.6m.
- (c) Minimum bracket strength rating = B1.
- (d) Minimum pole or strut strength rating = S11.

**Table 3.4 gives:**

- (a) Inspecting the route of the service line shows that 3m is required.
- (b) Adding 0.6m sag to 3m gives a free length to lowest conductor support = 3.6m.

If the structure is a **square hardwood post:**

- (a) Refer to Table 3.9.
- (b) For a free length to lowest conductor support of 3.6m.
- (c) Select an S rating of S11 or higher gives.
- (d) Minimum size is a 125mm x 125mm post.

If the structure is a **square hardwood strut (figure 3.7):**

- (a) Refer to Table 3.10.
- (b) For a free length to lowest conductor support of say 1.4m to obtain clearances.
- (c) Select an S rating of S11 or higher.
- (d) Minimum size is 100mm x 100mm strut.

If the structure is an **angle iron strut grade 250:**

- (a) Refer to Table 3.12.
- (b) For a free length to lowest conductor support of 0.2m.
- (c) Select an S rating of S11 or higher gives.
- (d) Minimum size is 40mm x 40mm, thickness = 6mm.

Other conductor support structures are handled using the same method.

**Table 3.8: Force Exerted by Overhead Service Lines**

Size of Service	Service Line Conductor Size mm <sup>2</sup>	Weight of Conductor (kg/m)	Service Line Span (m)	Normal Service Line Sag (m)	Maximum Allowable Service Line Sag (m)	Normal Service Line Tension (kN)	Minimum Service Line Breaking Tension (kN)	Minimum Bracket Strength (S rating)	Minimum Pole or Strut Strength Rating
100 A 1 phase	1 x 16 Cu Twisted Twin XLPE#	0.35	10	0.09	0.2	0.49	12.4	A1	S4
			15	0.17	0.4	0.58		A1	S7
			20	0.26	0.6	0.67		B1	S9
			30	0.43	1.0	0.92		B1	S13
			40	0.57	1.3	1.23		D1	S17
			50	0.73	2.0	1.50		D1	S20
	1 x 25 Al Twisted Twin XLPE	0.2	10	0.09	0.2	0.28	7	A1	S1
			15	0.17	0.4	0.33		A1	S2
			20	0.26	0.6	0.38		A1	S3
			30	0.43	1.0	0.52		A1	S5
			40	0.57	1.3	0.70		B1	S10
			50	0.73	2.0	0.86		B1	S12
100 A 3 phase	2 x 16 Cu Twisted Twin XLPE	0.7	10	0.09	0.2	0.97	24.8	B2	S14
			15	0.17	0.4	1.16		B2	S16
			20	0.26	0.6	1.35		D2	S18
			30	0.43	1.0	1.83		D2	S22
			40	0.57	1.3	2.46			S25
			50	0.73	2.0	3.00			S28
	1 x 25 Al 4 core LVABC	0.4	10	0.09	0.2	0.56	14	A1	S6
			15	0.17	0.4	0.66		B1	S8
			20	0.26	0.6	0.77		B1	S11
			30	0.43	1.0	1.05		B1	S15
			40	0.57	1.3	1.40		D1	S19
			50	0.73	2.0	1.71		D1	S21
200 A 3 phase	1 x 95 Al 4 core LVABC	1.35	10	0.09	0.2	1.88	53.2	D1	S23
			15	0.17	0.4	2.23			S24
			20	0.26	0.6	2.57			S26
			30	0.59	1.0	2.57			S26
			40	1.05	1.3	2.57			S26
			50	1.64	2.0	2.57			S26
300/400 A 3 phase	2 x 95 Al 4 core LVABC	2.7	10	0.09	0.2	3.75	106.4		S29
			15	0.17	0.4	4.47			S30
			20	0.26	0.6	5.14			S31
			30	0.59	1.0	5.14			S31
			40	1.05	1.3	5.14			S31
			50	1.64	2.0	5.14			S31

Note: **Maximum allowable service line sag (m):** has to be allowed for when determining adequate clearances (refer to Note 3 of Table 3.4).

# Data provided for reference and for alterations where the service doesn't need to be extended. Refer clause 3.1.5.1 and Table 3.1.



**Table 3.9: Square Hardwood Post (100MPa timber to AS 2209) Strength Ratings**

Free length to lowest conductor support (m)	Direct in ground	Concrete in ground	Direct in ground	Concrete in ground	Direct in ground	Concrete in ground	Direct in ground	Concrete in ground	Direct in ground	Concrete in ground
	100mm x 100mm	100mm x 100mm	125mm x 125mm	125mm x 125mm	150mm x 150mm	150mm x 150mm	175mm x 175mm	175mm x 175mm	200mm x 200mm	200mm x 200mm
3.0	S7	S7	S17	S17	S20	S24	S21	S29	S23	S29
3.3	S4	S4	S15	S15	S19	S23	S20	S28	S22	S29
3.6	S3	S3	S14	S14	S17	S22	S19	S26	S20	S28
3.9			S12	S12	S15	S20	S17	S26	S20	S28
4.2			S10	S10	S19	S19	S22	S25	S23	S29
4.5			S8	S8	S18	S18	S20	S24	S23	S28
4.8			S7	S7	S16	S16	S20	S23	S21	S28
5.1			S4	S4	S15	S15	S19	S23	S20	S28
5.4			S3	S3	S13	S13	S17	S21	S20	S26
5.7			S3	S3	S12	S12	S20	S20	S20	S26
6.0					S11	S11	S18	S19	S20	S24
6.3					S10	S10	S17	S17	S19	S23
6.6					S7	S7	S16	S16	S17	S23
6.9					S5	S5	S15	S15	S17	S22
7.2					S3	S3	S14	S14	S15	S20

**Table 3.10: Square Hardwood Struts (100MPa timber to AS 2209) Strength Ratings**

Free length to lowest conductor support (m)	100mm x 100mm	125mm x 125mm	150mm x 150mm	175mm x 175mm	200mm x 200mm
0.3					
0.6	S29				
0.9	S27	S32			
1.2	S23	S29	S32		
1.5	S20	S28	S32		
1.8	S17	S25	S29		
2.1	S14	S23	S29	S32	
2.4	S12	S21	S28	S32	
2.7	S10	S20	S27	S30	
3	S7	S18	S25	S29	S32

**Table 3.11: Round Hardwood Pole (100MPa timber to AS 2209) Strength Ratings**

Free length to lowest conductor support (m)	Height reduced from base 8m/2kN	Height reduced from base 8m/4kN	Height reduced from base 8m/6kN	Height reduced from base 9.5m/2kN	Height reduced from base 9.5m/4kN	Height reduced from base 9.5m/6kN
3.0	S23	S29	S32	S23	S29	S32
3.3	S23	S29	S32	S23	S29	S32
3.6	S23	S29	S32	S23	S29	S32
3.9	S23	S29	S32	S23	S29	S32
4.2	S23	S29	S32	S23	S29	S32
4.5	S23	S29	S32	S23	S29	S32
4.8	S23	S29	S32	S23	S29	S32
5.1	S23	S29	S32	S23	S29	S32
5.4	S23	S29	S32	S23	S29	S32
5.7	S23	S29	S32	S23	S29	S32
6.0	S23	S29	S32	S23	S29	S32
6.3	S23	S29	S32	S23	S29	S32
6.6		S29	S32	S23	S29	S32
6.9		S29	S32	S23	S29	S32
7.2		S29	S32	S23	S29	S32

Free length to lowest conductor support (m)	Height reduced from top 8m/2kN	Height reduced from top 8m/4kN	Height reduced from top 8m/6kN	Height reduced from top 9.5m/2kN	Height reduced from top 9.5m/4kN	Height reduced from top 9.5m/6kN
3.0	S29			S32		
3.3	S29			S30		
3.6	S28			S29		
3.9	S28	S32		S29		
4.2	S28	S32		S29		
4.5	S27	S32		S28		
4.8	S27	S32		S28	S32	
5.1	S25	S30		S28	S32	
5.4	S24	S30	S32	S27	S32	
5.7	S23	S29	S32	S27	S32	
6.0	S23	S29	S32	S27	S32	
6.3	S23	S29	S32	S25	S30	
6.6				S24	S30	
6.9				S24	S30	S32
7.2				S23	S29	S32

**Notes:**

- Height reduced from top:** A standard pole is reduced in length by cutting off a section from the top of the pole.
- Height reduced from base:** A standard pole is reduced in length by cutting off a section from the bottom of the pole.
- The Table shows, reducing the height from the:
  - top increases the kN rating of the pole
  - bottom results in an unchanged kN rating of the pole.

**Table 3.12: Angle Iron Struts Grade 250  
(cross-section dimensions x thickness (mm)) Strength Ratings**

Free length to lowest conductor support (m)	25x25 x 6	30x30 x 5	30x30 x 6	40x40 x 3	40x40 x 5	40 x 40 x 6	45x45 x 3	45x45 x 5	45x45 x 6
0.3	S1	S2	S3	S3	S10	S12	S7	S13	S16
0.6					S2	S3	S1	S3	S6
0.9								S1	S2
1.2									
1.5									
1.8									
2.1									
2.4									
2.7									
3									

Free length to lowest conductor support (m)	50x50 x 3	50x50 x 5	50x50 x 6	50x50 x 8	55x55 x 5	55 x 55 x 6	65 x 65 x 5	65 x 65 x 6	65 x 65 x 8	65 x 65 x 10
0.3	S10	S16	S20	S21	S19	S24	S23	S27	S28	S29
0.6	S2	S7	S10	S12	S10	S16	S14	S17	S20	S23
0.9		S2	S3	S6	S3	S10	S7	S11	S15	S17
1.2			S2	S3	S1	S5	S3	S7	S11	S12
1.5				S1		S3	S2	S3	S7	S9
1.8						S1		S2	S3	S5
2.1								S1	S3	S3
2.4									S1	S2
2.7										S1
3										

Free length to lowest conductor support (m)	75 x 75 x 5	75 x 75 x 6	75 x 75 x 8	75 x 75 x 10	90 x 90 x 6	90 x 90 x 8	90 x 90 x 10	100 x 100 x 6	100 x 100 x 8	100 x 100 x 10	100 x 100 x 12
0.3	S26	S28	S30	S32	S30	S32		S32			
0.6	S17	S21	S24	S27	S24	S28	S29	S27	S29	S30	S32
0.9	S11	S15	S19	S21	S20	S23	S27	S23	S27	S28	S29
1.2	S7	S11	S15	S17	S16	S20	S23	S19	S23	S24	S27
1.5	S3	S7	S11	S14	S12	S16	S20	S15	S20	S23	S24
1.8	S2	S4	S8	S11	S10	S14	S16	S12	S17	S20	S23
2.1		S3	S5	S7	S7	S11	S14	S10	S14	S17	S20
2.4		S1	S3	S5	S3	S9	S11	S7	S11	S15	S17
2.7			S2	S3	S3	S6	S10	S3	S10	S13	S16
3			S1	S2	S1	S3	S7	S3	S7	S11	S14

**Table 3.13: Angle Iron Struts Grade 300 Strength Ratings  
(cross-section dimensions x thickness (mm))**

Free length to lowest conductor support (m)	125 x 125 x 8	125 x 125 x 10	125 x 125 x 12	125 x 125 x 16	150 x 150 x 10	150 x 150 x 12	150 x 150 x 16	150 x 150 x 19	200 x 200 x 13
0.3									
0.6									
0.9	S30	S32							
1.2	S28	S30	S32		S32				
1.5	S27	S28	S30	S32	S32	S32			
1.8	S24	S28	S28	S30	S29	S32			
2.1	S23	S27	S28	S29	S28	S30	S32	S32	
2.4	S21	S24	S27	S28	S28	S29	S32	S32	
2.7	S20	S23	S25	S28	S27	S28	S30	S30	S32
3	S19	S21	S23	S27	S25	S28	S29	S30	S32

**Table 3.14: Fabricated Riverton Octagonal Steel Pole Strength Ratings**

Free length to lowest conductor support (m)	Octagonal Pole
3.0	
3.3	
3.6	
3.9	
4.2	
4.5	
4.8	S16
5.1	S16
5.4	

Note: These poles should not be modified.

**Table 3.15: Grade 250 Steel Pipe (diameter x thickness (mm)) Strength Ratings**

Free length to lowest conductor support (m)	34 x 3.2	34 x 4	34 x 4.5	42 x 3.2	42 x 4	42 x 4.9	48 x 3.2	48 x 4	48 x 5.4	60 x 3.6	60 x 4.5	60 x 5.4	76 x 3.6
0.3	S15	S17	S19	S22	S23	S26	S24	S27	S28	S29	S32	S32	
0.6	S5	S7	S10	S12	S15	S17	S16	S19	S22	S23	S27	S28	S28
0.9	S2	S3	S3	S7	S10	S11	S11	S13	S17	S19	S21	S23	S24
1.2		S1	S2	S3	S5	S7	S7	S10	S12	S15	S17	S20	S21
1.5				S2	S3	S4	S3	S6	S10	S11	S14	S16	S18
1.8					S1	S2	S2	S3	S7	S9	S11	S14	S15
2.1							S1	S2	S3	S6	S10	S11	S13
2.4									S2	S3	S7	S10	S11
2.7										S3	S4	S6	S10
3										S2	S3	S3	S7
3.3											S2	S2	S5
3.6												S1	S3
3.9													S3
4.2													S2
4.5													S1

Free length to lowest conductor support (m)	76 x 4.5	76 x 5.9	89 x 4	89 x 5	89 x 5.9	102 x 4	102 x 5	114 x 4.5	114 x 5.4	140 x 5	140 x 5.4	165 x 5	165 x 5.4
0.6	S29	S32	S32			S32							
0.9	S27	S28	S28	S30	S30	S29	S32	S32					
1.2	S23	S27	S27	S28	S29	S28	S29	S30	S32				
1.5	S20	S23	S23	S27	S28	S26	S28	S29	S30	S32			
1.8	S18	S21	S21	S24	S25	S23	S27	S28	S29	S32	S32		
2.1	S16	S20	S19	S23	S23	S21	S24	S27	S28	S30	S30	S32	
2.4	S14	S17	S17	S20	S21	S20	S23	S24	S27	S29	S29	S32	S32
2.7	S12	S15	S15	S19	S20	S18	S22	S23	S25	S28	S29	S31	S32
3	S11	S14	S14	S17	S19	S16	S20	S23	S24	S28	S28	S30	S30
3.3	S9	S12	S12	S16	S17	S15	S19	S20	S23	S27	S28	S29	S30
3.6	S7	S10	S11	S14	S15	S13	S17	S20	S22	S27	S27	S29	S29
3.9	S4	S7	S10	S12	S14	S12	S16	S18	S20	S24	S27	S28	S28
4.2	S3	S5	S7	S11	S12	S11	S15	S17	S20	S23	S24	S28	S28
4.5	S2	S3	S5	S9	S11	S10	S14	S16	S19	S23	S23	S27	S28
4.8	S2	S3	S4	S7	S9	S7	S12	S15	S17	S22	S23	S27	S27
5.1	S1	S2	S3	S5	S7	S7	S11	S14	S16	S21	S22	S25	S27
5.4		S1	S3	S3	S5	S5	S10	S12	S15	S20	S21	S24	S25
5.7		S1	S2	S3	S3	S3	S7	S11	S14	S19	S20	S23	S24
6			S1	S3	S3	S3	S7	S10	S12	S18	S20	S23	S23
6.3			S1	S2	S3	S3	S5	S9	S11	S17	S19	S23	S23
6.6				S1	S2	S2	S3	S7	S10	S16	S17	S21	S23
6.9				S1	S2	S1	S3	S7	S9	S15	S16	S20	S21
7.2					S1		S3	S5	S7	S14	S15	S20	S20

**Table 3.16: Grade 350 Steel Pipe (diameter x thickness (mm)) Strength Ratings**

Conductor Support (m)	34 x 2	34 x 2.6	42 x 2	42 x 2.6	48 x 2.3	48 x 2.9	60 x 2.3	60 x 2.9	76 x 2.3	76 x 2.3	89 x 2.6	89 x 3.2	89 x 4.8	89 x 5.5	102 x 2.6	102 x 3.2	114 x 3.2	114 x 3.6	114 x 4.8	114 x 6	140 x 3	140 x 3.5	140 x 3	165 x 3	165 x 3.5	168 x 4.8	168 x 6.4	168 x 7.1	219 x 4.8	219 x 6.4	
0.3	S15	S17	S21	S23	S25	S28	S29	S30	S32	-	-	-	-	-	-	-	-	-	-	-	-	-	-	-	-	-	-	-	-	-	-
0.6	S5	S7	S11	S15	S17	S20	S23	S25	S28	S29	S30	S32	-	-	S32	-	-	-	-	-	-	-	-	-	-	-	-	-	-	-	-
0.9	S2	S3	S5	S10	S11	S14	S17	S20	S23	S27	S28	S29	S32	S32	S29	S32	S32	-	-	-	-	-	-	-	-	-	-	-	-	-	-
1.2	-	-	S3	S4	S7	S10	S14	S16	S20	S23	S25	S28	S29	S30	S28	S29	S30	S32	-	-	-	S32	-	-	-	-	-	-	-	-	-
1.5	-	-	-	S1	S3	S5	S11	S13	S17	S21	S23	S24	S28	S29	S26	S28	S29	S30	S32	-	-	S32	S32	-	-	-	-	-	-	-	-
1.8	-	-	-	-	S1	S2	S7	S10	S14	S19	S20	S23	S27	S28	S23	S27	S28	S29	S30	S32	-	S30	S32	S32	-	-	-	-	-	-	-
2.1	-	-	-	-	-	-	S3	S6	S12	S16	S18	S20	S25	S27	S21	S24	S27	S28	S29	S32	S32	S29	S30	S32	S32	-	-	-	-	-	-
2.4	-	-	-	-	-	-	S2	S3	S10	S14	S16	S19	S23	S24	S20	S23	S25	S27	S28	S30	S32	S28	S29	S30	S32	S32	-	-	-	-	-
2.7	-	-	-	-	-	-	S1	S2	S6	S11	S14	S17	S21	S23	S18	S20	S23	S24	S28	S29	S30	S28	S29	S30	S32	S32	-	-	-	-	-
3	-	-	-	-	-	-	-	-	S3	S7	S11	S14	S19	S20	S16	S20	S23	S23	S24	S28	S29	S27	S28	S29	S30	S32	S32	-	-	-	-
3.3	-	-	-	-	-	-	-	-	S3	S5	S10	S11	S16	S17	S15	S17	S21	S23	S27	S28	S29	S27	S28	S29	S30	S32	S32	-	-	-	-
3.6	-	-	-	-	-	-	-	-	S1	S3	S7	S10	S14	S15	S12	S15	S20	S21	S23	S27	S28	S24	S27	S28	S29	S32	S32	-	-	-	-
3.9	-	-	-	-	-	-	-	-	S2	S4	S4	S7	S12	S14	S10	S13	S17	S19	S23	S24	S24	S23	S24	S27	S28	S30	S32	-	-	-	-
4.2	-	-	-	-	-	-	-	-	S1	S3	S5	S10	S11	S11	S7	S11	S15	S17	S20	S23	S24	S23	S24	S27	S28	S30	S32	-	-	-	-
4.5	-	-	-	-	-	-	-	-	S1	S3	S3	S7	S10	S10	S6	S9	S14	S15	S19	S21	S20	S23	S24	S27	S29	S32	S32	-	-	-	-
4.8	-	-	-	-	-	-	-	-	S2	S3	S6	S7	S6	S7	S4	S7	S12	S14	S17	S20	S19	S23	S25	S29	S32	S32	-	-	-	-	-
5.1	-	-	-	-	-	-	-	-	S1	S2	S4	S6	S3	S4	S3	S5	S11	S12	S15	S18	S18	S20	S23	S24	S28	S30	S32	-	-	-	-
5.4	-	-	-	-	-	-	-	-	-	-	-	S1	S3	S4	S3	S9	S11	S14	S16	S16	S16	S19	S21	S23	S28	S29	S30	S32	-	-	-
5.7	-	-	-	-	-	-	-	-	-	-	-	S1	S3	S3	S2	S3	S7	S9	S12	S15	S15	S17	S20	S23	S28	S29	S30	S32	-	-	-
6	-	-	-	-	-	-	-	-	-	-	-	S2	S3	S3	S1	S3	S6	S7	S11	S14	S14	S15	S20	S23	S27	S29	S30	S32	-	-	-
6.3	-	-	-	-	-	-	-	-	-	-	-	S2	S2	S2	S1	S2	S4	S6	S10	S12	S12	S14	S19	S21	S24	S28	S29	S30	S32	-	-
6.6	-	-	-	-	-	-	-	-	-	-	-	S1	S2	-	S1	S3	S5	S9	S11	S11	S13	S17	S20	S24	S27	S28	S29	S32	-	-	-
6.9	-	-	-	-	-	-	-	-	-	-	-	-	S1	-	S1	S3	S3	S7	S10	S10	S12	S16	S19	S23	S27	S28	S29	S32	-	-	-
7.2	-	-	-	-	-	-	-	-	-	-	-	-	S1	-	S1	S3	S3	S6	S9	S9	S11	S15	S17	S23	S24	S27	S29	S32	-	-	-

Section 3 - Overhead Services

**Table 3.17: Grade 350 Steel Square Section (width x thickness (mm)) Strength Ratings**

Free length to lowest conductor support (m)	30 x 2	30 x 2.5	30 x 3	35 x 1.6	35 x 2	35 x 2.5	35 x 3	40 x 1.6	40 x 2	40 x 2.5	40 x 3	40 x 4	50 x 1.6	50 x 2	50 x 2.5	50 x 3	50 x 4	50 x 5	65 x 2	65 x 2.5	65 x 3	65 x 4	65 x 5	65 x 6
0.3	S12	S15	S17	S14	S20	S19	S21	S17	S20	S23	S24	S27	S23	S26	S28	S28	S30	S32	S29	S32				
0.6	S3	S5	S7	S4	S11	S10	S11	S7	S11	S14	S15	S19	S13	S17	S20	S22	S25	S27	S23	S27	S28	S29	S30	S32
0.9	S1	S2	S3	S1	S5	S3	S6	S3	S5	S7	S10	S13	S7	S11	S14	S16	S20	S22	S17	S21	S23	S27	S28	S29
1.2					S2	S2	S3	S1	S2	S3	S5	S10	S3	S7	S10	S12	S16	S18	S14	S17	S20	S23	S25	S27
1.5							S1		S1	S2	S3	S5	S2	S3	S7	S10	S13	S15	S10	S14	S17	S20	S23	S24
1.8										S1	S1	S2		S2	S3	S6	S11	S12	S7	S11	S14	S17	S20	S23
2.1														S1	S3	S3	S7	S9	S4	S10	S11	S15	S18	S20
2.4															S1	S3	S3	S4	S3	S7	S10	S13	S16	S18
2.7																S1	S2	S3	S2	S4	S7	S11	S14	S15
3																	S1	S2	S1	S3	S5	S10	S11	S12
3.3																				S2	S3	S7	S9	S10
3.6																				S1	S3	S4	S6	S7
3.9																					S2	S3	S4	S5
4.2																					S1	S2	S3	S3
4.5																						S1	S2	S3
4.8																						S1	S1	S2
5.1																							S1	S1
5.4																								S1

Free length to lowest conductor support (m)	75 x 2.5	75 x 3.0	75 x 3.5	75 x 4.0	75 x 5.0	75 x 6.0	89 x 3.5	89 x 5.0	89 x 6.0	100 x 3.0	100 x 4.0	100 x 5.0	100 x 6.0	100 x 9.0	125 x 4.0	125 x 5.0	125 x 6.0	125 x 9.0	150 x 5.0	150 x 6.0	150 x 9.0	200 x 5.0	200 x 6.0	200 x 9.0
0.3	S32																							
0.6	S28	S29	S30	S32	S32																			
0.9	S24	S27	S28	S29	S30	S32	S30	S32		S30	S32													
1.2	S20	S23	S24	S27	S28	S29	S28	S30	S32	S28	S30	S32												
1.5	S17	S20	S23	S24	S27	S28	S27	S29	S30	S27	S29	S30	S32		S32									
1.8	S15	S18	S20	S22	S24	S27	S24	S28	S29	S24	S28	S29	S30	S32	S30	S32								
2.1	S12	S15	S17	S20	S23	S23	S23	S27	S28	S23	S27	S28	S29	S32	S29	S32	S32							
2.4	S10	S14	S15	S17	S20	S23	S20	S24	S27	S20	S24	S28	S28	S30	S28	S30	S32		S32					
2.7	S7	S11	S14	S16	S19	S20	S19	S23	S24	S19	S23	S27	S28	S30	S28	S29	S30		S32					
3	S6	S10	S12	S14	S17	S19	S17	S21	S23	S17	S23	S24	S27	S29	S27	S29	S30	S32	S32	S32				
3.3	S3	S7	S10	S12	S15	S17	S15	S20	S23	S15	S20	S23	S25	S28	S25	S28	S29	S32	S30	S32				
3.6	S3	S6	S9	S11	S13	S14	S14	S19	S21	S13	S20	S23	S24	S28	S24	S28	S28	S32	S29	S32			S32	
3.9	S2	S4	S7	S9	S11	S12	S12	S17	S20	S11	S18	S21	S23	S28	S23	S27	S28	S30	S29	S30			S32	
4.2	S1	S3	S5	S7	S9	S11	S11	S16	S18	S10	S17	S20	S23	S27	S22	S26	S28	S30	S28	S30	S32	S32		
4.5		S3	S3	S4	S7	S9	S10	S15	S16	S9	S15	S19	S21	S24	S20	S24	S27	S29	S28	S29	S32	S31		
4.8		S2	S3	S3	S5	S7	S7	S13	S15	S7	S14	S17	S20	S23	S20	S23	S27	S29	S28	S29	S32	S30	S32	
5.1		S1	S2	S3	S3	S5	S6	S11	S13	S5	S12	S16	S18	S21	S19	S23	S24	S28	S27	S28	S32	S29	S32	
5.4			S1	S2	S3	S3	S4	S10	S11	S3	S11	S15	S16	S20	S17	S22	S24	S28	S27	S28	S30	S29	S32	
5.7				S1	S2	S3	S3	S7	S10	S3	S10	S13	S15	S19	S16	S20	S23	S28	S25	S28	S30	S29	S32	
6				S1	S2	S3	S3	S7	S9	S2	S9	S12	S14	S17	S15	S20	S23	S27	S24	S27	S30	S28	S30	
6.3					S1	S2	S2	S5	S7	S1	S7	S11	S12	S16	S14	S19	S21	S25	S23	S27	S29	S28	S30	
6.6						S1	S1	S4	S5		S5	S10	S11	S15	S12	S17	S20	S24	S23	S26	S29	S28	S29	
6.9						S1		S3	S4		S3	S8	S10	S14	S11	S17	S20	S23	S22	S24	S29	S27	S29	
7.2								S3	S3		S3	S7	S9	S12	S10	S15	S19	S23	S20	S24	S28	S27	S29	S32

**Table 3.18: Grade 450 Steel Square Section (width x thickness (mm)) Strength Ratings**

Free length to lowest conductor support (m)	30 x 1.6	30 x 2	35 x 1.6	35 x 2	35 x 2.3	35 x 2.5	35 x 2.8	35 x 3	40 x 1.6	40 x 2	40 x 2.3	40 x 2.5	40 x 2.8	40 x 3	40 x 4	50 x 1.6	50 x 2	50 x 2.3	50 x 2.5	50 x 2.8	50 x 3	50 x 4	
0.3	S13	S15	S17	S20	S21	S23	S23	S24	S20	S23	S24	S25	S27	S27	S29	S24	S28	S29	S29	S30	S30	S32	
0.6	S3	S6	S7	S11	S12	S13	S14	S15	S11	S14	S16	S17	S18	S19	S22	S15	S20	S23	S23	S24	S24	S28	
0.9	S1	S2	S3	S4	S6	S7	S9	S10	S5	S9	S11	S11	S12	S14	S17	S10	S15	S17	S17	S19	S20	S23	
1.2			S1	S2	S3	S3	S3	S3	S4	S6	S7	S9	S10	S11	S5	S11	S12	S14	S15	S15	S19	S19	
1.5							S1	S1	S1	S2	S3	S3	S3	S3	S5	S3	S7	S10	S10	S11	S12	S15	
1.8													S1	S1	S1	S2	S2	S4	S6	S7	S7	S9	S11
2.1																	S2	S3	S3	S3	S4	S7	
2.4																	S1	S1	S2	S2	S3	S3	
2.7																				S1	S1	S2	
3																						S1	

Free length to lowest conductor support (m)	50 x 5	65 x 2	65 x 2.3	65 x 2.5	65 x 3	65 x 4	65 x 5	65 x 6	75 x 2	75 x 2.3	75 x 2.5	75 x 3	75 x 3.5	75 x 4	75 x 5	75 x 6	100 x 3	100 x 4	100 x 5	100 x 6	
0.3		S30	S32	S32					S32												
0.6	S28	S24	S27	S28	S29	S32	S32		S27	S28	S29	S32	S32								
0.9	S24	S20	S23	S24	S27	S28	S29	S30	S23	S24	S27	S28	S29	S30	S32	S32	S32				
1.2	S21	S16	S19	S20	S23	S27	S28	S29	S19	S21	S23	S27	S28	S28	S29	S30	S29	S32			
1.5	S17	S12	S15	S17	S20	S23	S25	S27	S15	S19	S20	S23	S25	S27	S28	S29	S28	S30	S32		
1.8	S12	S10	S13	S15	S17	S21	S23	S24	S12	S15	S17	S21	S23	S24	S27	S28	S27	S29	S32	S32	
2.1	S9	S7	S10	S12	S15	S19	S20	S22	S10	S13	S15	S19	S21	S23	S24	S27	S24	S28	S30	S32	
2.4	S4	S4	S7	S10	S12	S15	S17	S19	S7	S11	S13	S17	S19	S20	S23	S24	S23	S28	S29	S30	
2.7	S3	S3	S5	S7	S10	S12	S14	S15	S5	S9	S11	S15	S17	S19	S20	S22	S20	S27	S28	S29	
3	S2	S2	S3	S4	S7	S10	S11	S12	S3	S7	S9	S13	S14	S15	S17	S19	S19	S24	S28	S28	
3.3		S1	S3	S3	S3	S7	S9	S10	S2	S4	S7	S10	S11	S13	S15	S17	S17	S23	S27	S28	
3.6			S1	S2	S3	S4	S6	S7	S1	S3	S4	S7	S10	S11	S13	S14	S15	S23	S24	S27	
3.9			S1	S1	S2	S3	S4	S5		S2	S3	S5	S7	S9	S11	S12	S14	S21	S23	S24	
4.2					S1	S2	S3	S3		S1	S3	S3	S5	S7	S9	S11	S12	S19	S21	S23	
4.5						S1	S2	S3			S2	S3	S3	S4	S7	S9	S11	S17	S20	S21	
4.8						S1	S1	S2					S2	S3	S3	S5	S7	S10	S15	S18	S20
5.1							S1	S1					S1	S2	S3	S3	S5	S7	S14	S16	S18
5.4								S1					S1	S1	S2	S3	S3	S5	S12	S15	S16
5.7														S1	S1	S2	S3	S3	S11	S13	S15
6															S1	S2	S3	S3	S10	S12	S14
6.3																S1	S2	S2	S8	S11	S12
6.6																	S1		S7	S10	S11
6.9																	S1		S5	S8	S10
7.2																			S4	S7	S9



## 4 SERVICE AND METERING EQUIPMENT

(Including Current Transformer metering and installations with Main Switchboards rated above 100 Amps per phase)

### 4.1 Introduction

The customer must arrange to provide and install at the customer's cost:

- (a) Service Protection Device.
- (b) Meter Protection Device(s).
- (c) Service neutral/active links.
- (d) Metering and load control devices.
- (e) The meter/switchgear enclosure.
- (f) Associated wiring and connections in accordance with AS/NZS 3000.
- (g) Any other service or metering equipment required.

The enclosure must be in a location and in conditions acceptable to the electricity distributor and metering provider.

Responsibility for the revenue metering shall transfer to the Metering Provider upon connection of supply. Responsibility for **stand-alone** Demand Indicators and/or load control devices used for network management purposes will be transferred to the distributor upon connection of supply

The electricity distributor or the nominated metering provider will maintain the metering and load control equipment accordingly.

The electricity distributor will assess the maximum demand for service and metering equipment. Where it exceeds 100A per phase or the current rating of a meter for separately metered parts of an installation, the Metering Provider at their discretion may require Current Transformer (CT) metering to be installed. In all other cases whole current metering will be installed.

All installations are to be arranged to be metered through the minimum number of standard meters. Refer to clause 4.11.1.

#### 4.1.1 Existing Installations

In general where metering installations are changed or relocated, standard metering arrangements required by this Section apply.

You may install additional service and metering equipment on an existing board if the additions can be accommodated without relocating existing metering equipment.

If it is necessary to install additional panels, these panels may be either:

- (a) In the standard arrangements which are outlined in this document, or
- (b) Matched to the existing style.

Where new tenancies are created in an existing non domestic multiple installation and insufficient room exists at a common metering point the metering may be:

- (c) Located on the exterior wall of its associated tenancy.
- (d) In all cases where no practical alternative exists contact your local Electricity Distributor.

Where additional whole current service and metering equipment is required you must also comply with the provisions for the isolation requirements of clause 4.13.

### 4.2 Location and Accessibility of Service and Metering Equipment

Service and metering equipment must be in an accessible area on common property.

For installations on non-urban properties exceeding 0.4 Hectare (Ha) in area, apply to the electricity distributor regarding a suitable meter location.

The customer must ensure that access to any enclosure for meters or service and metering

equipment is never restricted or made unsafe. The location must always be kept clear.

If access is obstructed the customer must remove the obstruction or relocate the service and metering equipment.

Rooms dedicated to house service and metering equipment must be well lit, clean, unobstructed and not used for storage of materials or equipment. The door(s) of rooms

and enclosures housing metering equipment must be labelled "Electricity Meters".

Metering and load control equipment is to be easily accessible to distributor and metering provider officers within normal working hours. Where the metering equipment is not located adjacent to the service protection device, its location must be labelled on the main switchboard. The labelling must comply with clause 4.21

As an alternative and subject to availability and agreement between the customer and the electricity distributor, an alternative metering system such as remote metering may be installed at the customer's expense.

Provide access to an elevated position as specified in AS 1657 'Fixed platforms, walkways, stairways and ladders - Design, construction and installation'.

Any gas meter, fittings, enclosures or other obstructions installed below the service metering panel must not project further than 300mm from the face of the wall on or in which the service metering panel is mounted.

Provide and maintain adequate space in front of the service and metering equipment panel or cabinet, to enable the equipment to be operated or adjusted.

The space must:

- (a) Be flat and level
- (b) Enable the door or panel to be opened or removed; and
- (c) Provide a vertical clearance of not less than 2 metres from the ground, platform or floor and minimum horizontal clearance of not less than 0.6 metre from the:
  - i) Equipment mounted on the hinged panel; or
  - ii) External front edge of the switchboard enclosure

whichever point protrudes the most.

When a hinged meter panel is extended on its hinge to the 90° open position, make sure a clearance of 200mm is maintained between the front face of the panel and any fixed object.

Provide a clearance of 175 mm from the front of the panel to the door.

Note: The local government Act requires compliance to the Building Code of Australia for **exits for fire escape** purposes, or any corridor, hallway, lobby or the like leading to such an exit. This does not apply in single dwellings. In the case of buildings being altered or the use being changed, the local council may require an existing building to be brought up to this standard.

#### **CAUTION**

**Whenever a property or building is of a type which may be subdivided, care should be taken to ensure that the meters and wiring are located within the area which would be set aside as common property or within the individual lot supplied thereby. Wiring installed within an individual lot must be associated only with that lot.**

#### **4.2.1 Single Domestic Premises**

The service and metering equipment must be located where ready pedestrian access is maintained, in one of the following locations:

- (a) On the face of the residence facing the front boundary.
- (b) On the adjacent side wall within 1.5m of that face or associated corner window or verandah.
- (c) On a private pole.
- (d) Within the front boundary fence so that distributor meter reading and maintenance of service and metering equipment may be carried out without introducing a safety hazard.

Where the main entrance is on the side of a residence the service and metering equipment may be installed on that side not further than 1.5 metres beyond the main entrance subject to access being available.

Suitable locations are shown in Figure 4.1.

The service and meter position must not be located behind fences or locked gates unless they are fitted with the electricity distributor standard locking facility. Refer to clause 4.6.

Where a perimeter or security fence is erected between the building and the access street it is recommended that a suitable vandal resistant meter box be installed in the fence.

As metering equipment may produce slight noise the installation of metering equipment on a bedroom wall should be avoided.

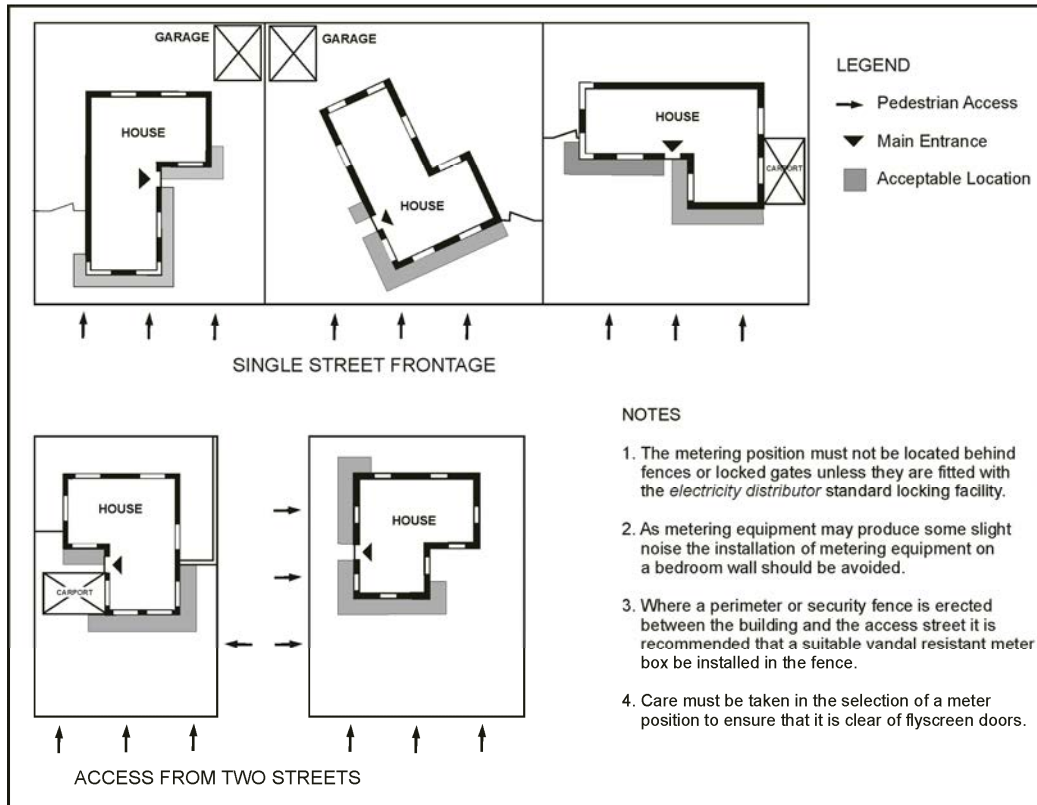
**Figure 4.1: Suitable Metering Locations for Single Domestic Installations**

#### 4.2.2 Single Business Premises

Unless otherwise approved by the electricity distributor, the service and metering equipment must be located as close as practicable to the entrance of the premises and must be readily accessible (in an area normally open to the public).

In addition, metering equipment must not be located in areas intended for product display such as shop windows or where access is restricted during normal operations for security, health or other reasons.

The service and metering equipment for single business premises within a multiple occupancy must be grouped at the associated common distribution board, external to the tenancies.

Access must be available during the electricity distributor's normal business hours.

#### 4.2.3 Multiple Occupancy Premises

The metering for new multiple occupancy premises will be grouped at the one metering position. Provision should be made to cater for any future metering requirements.

The grouped metering must be in a location accessible to all associated tenants. It must not be located within any one occupancy.

If located in a secured common area access must be available by means of a standard locking system obtained from the electricity distributor.

For practical reasons it may be necessary to provide more than one metering position. The following clauses shall apply.

##### 4.2.3.1 Multi-Storey Developments

In multi-storey developments, group the meters together on each floor or on each alternative floor as directed by the Metering Provider.

##### 4.2.3.2 High Density Residential Installations

In high density residential installations, the meters to be located on or adjacent to the main switchboard. Metering may be on an individual floor basis, where agreed to by the distributor.

##### 4.2.3.3 Medium Density Residential

Do not locate the metering within any individual occupancy's right of way in medium density residential developments (eg town houses, villa units, cluster homes, duplex units), and domestic installations which include a separate flat or unit.

##### 4.2.3.4 Factory Unit Developments, Shopping Centres and Malls

For factory unit developments, shopping centres and malls, locate the service and metering equipment external to the tenancies.

##### 4.2.3.5 Remotely Read Meters

Remotely read metering may be located within the tenancy at customers expense, refer to metering provider for approval.

### 4.3 Unsuitable Locations

Service and metering equipment must not be installed behind locked gates or doors unless the obstructions are fitted with acceptable access arrangements.

In addition the following locations are considered unsuitable for mounting service and metering equipment:

- (a) Over stairways or ramps, in narrow passageways, or in confined spaces.
- (b) In vehicle docks, driveways, factory passageways where the equipment or a person working on it would not be effectively protected.
- (c) In close proximity to, or over, machinery or open type switchgear.
- (d) Locations which are liable to be affected by fumes, vibration, dampness, or dust, which may cause deterioration of equipment or unsatisfactory working conditions.
- (e) In hazardous or prohibited switchboard locations as defined in the AS/NZS 3000.
- (f) Where the normal ambient temperature exceeds 50°C.
- (g) Where there is insufficient light.
- (h) Where exposed to direct sunlight.
- (i) Where the use of a ladder would be necessary.
- (j) Where projections at head height are a hazard.
- (k) In pool or spa zones as defined in AS/NZS 3000.
- (l) In carports, unless with the prior permission of the electricity distributor.
- (m) On enclosed verandahs.
- (n) In areas enclosing dogs.
- (o) In areas to which access is normally restricted - for security, health or other reasons. (This would include areas in which animals are kept for security reasons).
- (p) Behind a fence without a gate.
- (q) Within gas emitting devices exclusion zone, refer to AS 5601.
- (r) Within LPG cylinder minimum clearance to ignition sources refer to AS 5601.
- (s) In fire isolated stairways, passageways or corridors.
- (t) Where access is restricted by vegetation.
- (u) On the electricity distributor's asset.

See AS/NZS 2430.3.4 'Classification of hazardous areas Part 3.4 - Examples of area classification - Flammable gases'.

### 4.4 Hazards of Existing Meter and Switchboard Panels that may Contain Asbestos

Accredited Service Providers and electrical contractors should not carry out work that disturbs the integrity (eg drilling) of existing meter or switchboard panels that may contain asbestos, within electrical installations, without taking suitable precautions. Information in this regard is available from the SafeWork NSW website ([www.safework.nsw.gov.au](http://www.safework.nsw.gov.au)) which lists relevant industry safety guidelines and model procedures.

#### WARNING - ASBESTOS

**Historically, asbestos has been used in switchboard panels used in electrical installations. All electrical personnel who work on switchboard panels need to identify if this hazard may be present, and if necessary adopt approved industry procedures, when working with switchboard panels.**

## 4.5 Facilities for the Installation of Meter and Service Equipment

### 4.5.1 Service and Metering Equipment Panel

For all new installations the meter/switchgear panel must:

- (a) Not use materials containing asbestos.
- (b) Provide sufficient space for the installation of service and metering equipment, refer to the metering provider or your accredited service provider for equipment sizes.
- (c) Separate the service and metering equipment from the customer's equipment. Separation may be shown by marking.

### 4.5.2 Service and Metering Equipment Enclosure

Provide and install enclosures complying with AS/NZS 3000..

### 4.5.3 Free length of consumers mains/underground service

The free length of consumers mains/underground service to be installed, measured from where it passes through the hole in the panel, must be as follows: above fuse (line side) 75mm; below fuse (load side) 150mm. A similar length is required for the neutral conductor. All cables must be connected to the Service Protection Device and neutral link by the accredited service provider.

### 4.5.4 Physical Protection of Service and Metering Equipment

Service and metering equipment must be protected from:

- (a) The weather.
- (b) Mechanical damage.
- (c) Salt or dust laden air or corrosive atmospheres.
- (d) Vandalism.

An enclosure must be fitted with a door and catch.

### 4.5.5 Isolated and Unattended Locations

Where service or metering equipment is installed in an enclosure externally on a building or a pole in an isolated and unattended location, the enclosure must be constructed using galvanised steel or equivalent material of sufficient strength to achieve protection against vandalism, weather or other external factors. Such enclosures must be kept locked at all times using an acceptable locking system.

This requirement does not apply for service and metering equipment enclosures on construction sites.

### 4.5.6 Top Hinged Switchboard Doors

If the door is hinged at the top, provide a stay fastened to the enclosure to hold the door open greater than 90°.

### 4.5.7 Glazed Switchboard Doors

Do not glaze the door if the enclosure is exposed to sunlight or the risk of breakage is high.

### 4.5.8 Fixing of Service Equipment Enclosure

Ensure the facilities for mounting service and metering equipment and associated surrounds and enclosures, are securely fixed to a wall or rigid supporting structure.

### 4.5.9 Fixing of the Service and Metering Equipment

All service and metering equipment is to be secured using all available fixing points.

For panels with a thickness of less than 20mm, bolts and nuts must be used to secure the equipment.

Bolts must not protrude more than 5mm past the fixing nut, nor be capable of damaging any conductor insulation.

Where screws are used, they must not protrude past the rear of the panel. Screws must utilise at least 75% of the panel thickness to secure any equipment.

Where the head of any fixing device is exposed on the front of the panel, it must be suitably insulated.

## 4.6 Locking of Service and Metering Enclosures

Locking and restricting access to a meter enclosure or other enclosure for service equipment is acceptable if the lock or access is approved by the metering provider and or electricity distributor respectively, by means of a standard locking system obtained through the electricity distributor.

The following access arrangements are acceptable provided an officer of the electricity distributor and or metering provider is not required to reset security alarms:

- (a) Where electrically operated security locking is used, a key switch is to be provided and fitted with the electricity distributor's standard cylinder.
- (b) Where access is given by means of a security card, either a key switch as above

or a card left in a locked box provided by the customer and mounted adjacent to the entrance door which can be opened by the electricity distributor's standard key is to be provided. The lock box must be mounted no lower than 0.6 m or no more than 2.0m above the ground, floor or platform.

Note: The electricity distributor's locking system is a restricted key system not a high security system. The electricity distributor's locking system must not be installed on doors which give access to any rooms or areas in which portable articles and equipment of any value, personal goods and the like are located.

## 4.7 Service Protection and Metering Protection Devices

The customer must provide, install and maintain an approved service protection device and/or an approved meter protection device in accordance with the following sub clauses.

### 4.7.1 Selection of fuse carrier and base ratings for fuses as Service Protection Devices and Meter Protection Devices

The maximum current rating of any fuse carrier and fuse base combination (the fuse assembly) used for the purposes of a service protection device or a meter protection device shall always be equal to or greater than the fuse element rating, but in no case less than 100 Amps.

The fuse assembly must have a sealable escutcheon, known as an anti-intrusion assembly, which prevents access to the terminals. The fuse carrier does not have to be sealed to the fuse base.

### 4.7.2 Selection of Rating for Meter Protection Devices

The rating of the fuse element is to be in accordance with table 4.1. Alternative fuse element ratings or alternative protective devices may be used but in no case can the time-current protection rating exceed that of an 80A HRC fuse. Circuit breakers rated above 80 A can only be installed with the approval of the Metering Provider.

### 4.7.3 Service Protection Device and Meter Protection Device combined

For single customer installations that meet the requirements of a service type *100A single domestic* in table 4.1, the functions of a service protection device and a meter protection device can be fulfilled by the one physical device provided clause 4.7.2 is complied with.

This situation is represented in figure 4.2b.

### 4.7.4 Location of Service Protection Devices and Meter Protection Devices

- A) Meter protection devices must always be on the installation side of service protection devices.
- B) For installations with a consumer mains maximum demand determined in accordance with AS/NZS 3000 of up to the lesser of 100A per phase or the meter rating as determined by the Metering Provider, unless otherwise approved by the distributor the service protection device and any meter protection devices must be located at the meter position and on the distribution network side of the meters..
- C) For installations with a consumers mains maximum demand determined in accordance with AS/NZS 3000 exceeding the lesser of: 100A per phase or the current rating of a meter as determined by the Metering Provider (or otherwise metered with the use of current

transformers), the service protective device must be located adjacent to or incorporated in the main switchboard on the line side of the current transformers.

- D) Locate the service protective device no higher than 2.0m to the top of the device and no lower than 0.5m to the line side terminals (excluding any connection flags used) of the device above the ground floor or platform.

- E) The requirements of this subclause apply to alterations and additions to existing installations except where the relocation of the service protection device would require upgrading of the service, consumers mains or main switchboard, then the existing service protection device location may be maintained.

For special situations check with the distributor.

**Table 4.1: Examples of Suitable Service and Meter Protection Fuse element Combinations**

Service type	Service Protection Device (SPD) Element Rating	Meter Protection Device (MPD) Element Rating	Comments
100A Single domestic	1 X 100A (* see Note 6)	1 x 80A (*see Note 7)	For single domestic installations the SPD and the MPD can be one device but must be rated at the lower current carrying capacity (80A).
100A Multiple domestic	1 x 100A	multiple x 80A	For multiple domestic installations, there must be one SPD to provide overload protection to the service supplying the installation. A separate MPD must protect each separately metered installation, see note 4.
200A	1 x 200A	multiple x 80A	See Note 4
300A	1 x 300A/315A	multiple x 80A	This may cause some grading problems with substation distributor fuses, which if blown are not able to be replaced by the customer. See Note 4 If there are grading constraints, 250A fuse(s) may be used for the SPD as this size would be more likely to grade. See Note 4
400A	1 x 400A	multiple x 80A	This may cause some grading problems with substation distributor fuses, which if blown are not able to be replaced by the customer. Fuses must be to Class Q1 to BSS 88, 1975. You may be requested to install bars or have a combination of fuse ratings. See Note 4
Refer also to multiple customer arrangements shown in clause 4.14.			

Notes:

1. These examples are dependent on the loading of the various metered sections of an installation.
2. When using service protection devices of the larger sizes you must ensure that grading is achieved below those fuses. The grading prevents nuisance loss of supply as the Meter Protection fuse then protects a smaller portion of the installation by ensuring that the fault is seen by the fuse which is closest to the fault (between the fault and the supply).
3. With supplies direct from a substation, grading must be achieved.
4. Multiple 100 Amp service protection fuses per phase are allowed, when there is a single service protective device protecting the whole installation – contact your distributor for more information with each case.
5. Number of customers per 100 Amp service protection device / fuses is determined by the requirements of Clause 4.14.
6. For existing installations this rating may be reduced to reflect the current rating of existing consumers or sub mains and to accommodate load limiting in accordance with AS/NZS 3000 requirements.
7. This is a maximum rating for an MPD HRC fuse and may be reduced for installations with a lower maximum demand. In accordance with Clause 4.7.2, an MPD can be a Circuit Breaker but in any case must have time current characteristics that do not exceed that of an 80 amp HRC fuse. A circuit breaker MPD can be used as a load limiting device as per AS/NZS 3000.

Note: The 80 amp HRC fuse is to protect the Advanced Meter from damage due to through fault or substantial overload. Advanced Meters can tolerate cyclical loading up to 100 amps, short term overloads of up to 128 amps for 2 hours, and through fault currents of 3kA for half a cycle before being damaged. The 80 amp HRC fuse matches this protection requirement but can still carry 100 amps without operating.

**Figure 4.2a** Use of Service Protection Devices (SPD) and Meter Protection Devices (MPD) – example of Multiple occupancy installation

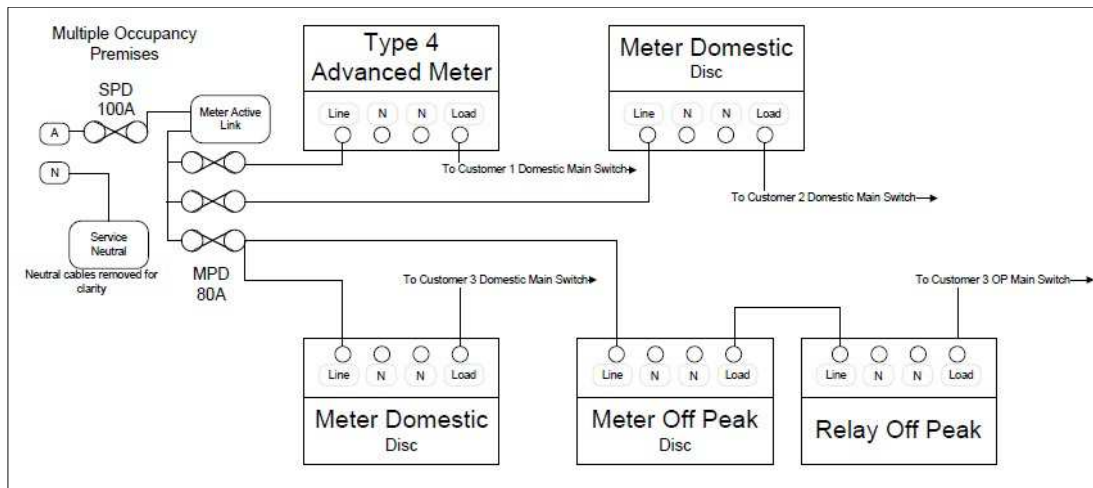

**Figure 4.2b** Use of Service Protection Device (SPD) and Meter Protection Device (MPD) – example of Single occupancy installation with combined SPD and MPD as per clause 4.7.3:

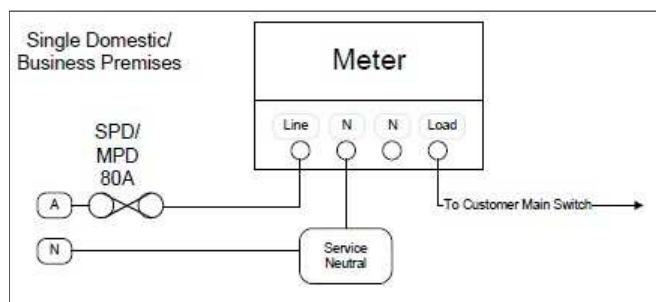

#### 4.7.5 100A Fuses as Service Protection Devices and or Meter Protection Devices

The 100A service protection fuses and meter protection fuses must comply with the following requirements:

- (a) The Service protection fuse assembly must accept a Type 11b 100A current limiting (HRC) fusible link. The fusible link must be manufactured in accordance with AS 60269.3.0\* and AS 60269.3.1\*.
- (b) (a) The Meter protection fuse assembly must accept a Type 11b 80A current limiting (HRC) fusible link. The fusible link must be manufactured in accordance with AS 60269.3.0\* and AS 60269.3.1\*.
- (b) The equipment must be supplied complete with the fusible link, fuse carrier, base and sealed escutcheon.
- (c) The fuse base may be either front or back connected.
- (d) The fuse base must have two load terminals, or you must provide a sealable active link for connection of more than one tariff or customer.
- (e) Connect one conductor only to each separate terminal. Protect unused terminals from accidental contact.
- (f) Where the service and or meter protection device consist of a base, insulating cover (turret) and fuse carrier, you must install and secure the insulating cover (turret) before the fuse carrier is inserted.
- (g) Where insulating barriers are provided on one terminal only, you must use that side of the fuse base for the line side connection. (Do not remove barriers).
- (h) If you have to use specialised insulated tools to make connections into the fuse base, you must follow the fuse manufacturer's instructions.
- (i) The fuse-link dimensions are shown in Figure 4.3.
- (j) Bolt-in style motor start fuses are an acceptable alternative to the fuse shown in Figure 4.3. Note: Bolt-in style motor fuses are not standard. Where used a spare set of fuse links is to be provided by the customer.

Note: Electrical installations on railway land in the 1500V dc electrified track area normally requires circuit breakers as service protective devices.

\*AS60269.3.0 & AS60269.3.1 are currently withdrawn



**Figure 4.3: 100A fuse link dimensions Type 11b**

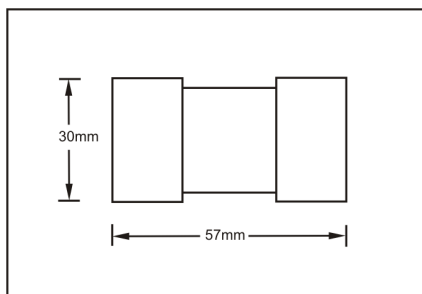

All Service Protection and Meter Protection HRC fuse links have potential to contain friable asbestos materials. Exposure to the asbestos inside may occur through accidental or mechanical damage. As such, when fuse links are replaced they must be removed and disposed of as asbestos waste. More information can be found on the SafeWork NSW website.

#### 4.7.6 Enclosures for Service Protection Device greater than 100A

Service protection devices exceeding 100 Amp rating must be designed and installed in accordance with Appendix ZC of AS 3439.1 – Type tested & partially type tested switchboard assemblies for arc fault minimisation.

#### 4.7.7 Service Protection Devices greater than 100A

Service protection devices exceeding 100A must comply with:

- (a) AS 60269.21.
- (b) IEC 269 Part 2-1 'Low Voltage Fuses'.
- (c) BS 88 Part 2, 1975 'Low Voltage Fuses'.
- (d) AS 60529-2004 'Degrees of protection provided by enclosures (IP Code)'.

The service protection device must also comply with the following requirements:

- (a) The assembly must be suitable for the installation of current limiting (HRC) fuses with a current rating from 200A to 400A.
- (b) Links must be current limiting (HRC), Type G, T or NHG (DIN) and must comply with Class Q1, to BS 88 part 2, 1975.
- (c) A rated voltage not less than 500V.
- (d) Rated breaking capacity not less than 80kA.
- (e) The equipment must be supplied with the requested current rated fusible links. Where requested by the distributor, solid links must be fitted in lieu of fuses.

- (f) The fuse-link dimensions must be B4 or C1 for bolted connected fuse links and Size 2, for blade connected fuse links.
- (g) Have phase segregation dividers fitted to prevent phase to phase faults or use separately enclosed phase fittings. Where practical the fixed contacts should be shrouded to reduce the risk of contact with live parts.
- (h) The fuse assembly must be contained by an insulated enclosure. If within a metal switchboard the sides of the enclosure must be insulated.
- (i) The fuse assembly cover must be able to be adequately sealed, with or without the fuse link fitted. No live parts must be exposed during the sealing operation.
- (j) The fuse assembly may be either front or back connected.
- (k) A combined fuse-switch unit with segregation is satisfactory.
- (l) Grade (discriminate) with the distributor's protection starting at 100ms and above and up to the arcing fault level deemed to be at 30% of the prospective short circuit current.

Where the service protective device consists of a base, insulating cover (turret) and fuse carrier, the insulating cover (turret) must be installed and secured before inserting the fuse carrier.

Where specialised insulated tools are necessary to make connections into the fuse base then the fuse manufacturer's instructions must be followed.

Service protective devices greater than 100A using fuses must be vertically orientated with fuse withdrawal towards the operator and must comply with clause 4.7 of this document.

#### 4.7.8 Circuit Breakers in Lieu of 100A Service Protection Fuse

In special circumstances and on application to the electricity distributor approval may be given to allow circuit breakers in lieu of a 100A service protection fuses.

Where approved the circuit breaker must comply with the requirements of clause 4.7.6.

Electrical installations on railway land in the railway 1500V dc electrified track area normally require circuit breakers instead of fuses.

#### 4.7.9 Circuit Breakers in Lieu of Service Protective Devices greater than 100A

Circuit breakers may be used as an alternative to service protective devices in accordance with the following requirements.

Circuit breakers to be installed must:

- (a) Be of the fault current limiting type, without considering the effects of cascading (if used).
- (b) Have a rated short circuit current capacity equal to or greater than the prospective short circuit current at the point of its installation.
- (c) Grade (discriminate) with the electricity distributor's protection.
- (d) Have the facility for locking and sealing in the 'off' position.
- (e) Comply with AS 3947.2 Low voltage switchgear and control gear - Circuit breakers and the emergency systems provisions of AS/NZS 3000.
- (f) Have any adjustable settings sealable such that only authorised persons have access. A sealed escutcheon does not satisfy this requirement.
- (g) Have unmetred active/live connections enclosed and have facilities for sealing to prevent unauthorised access.
- (h) Be maintained by the customer in accordance with the manufacturer's specifications.

- (i) Have a label describing the circuit breaker load current settings attached adjacent to the circuit breaker.

#### 4.7.10 Connection to Service Protection Devices

The line side connection of service protection devices must:

- (a) Be at the top where mounted vertically, or
- (b) Have the line side labelled.

#### 4.7.11 Identification

The Service Protection Device, and meter protection devices are to be clearly identified.

Every fuse that is used for meter and or service protection devices shall have the fuse link element rating clearly marked below the device.

Where the service and or meter protection devices are not fitted in accordance with these rules or are not clearly visible, a notation on the metering panel must describe the location of the devices

All labelling to be in a legible and durable manner, in accordance with the AS/NZS 3000.

## 4.8 Rewirable Fuses

When altering the service or consumers mains terminated at existing rewirable service protection fuses or carrying out any work on existing rewirable service protection fuses, the rewirable service protection fuse assembly

must be replaced with a service protection device complying with clause 4.7 of these Rules.

## 4.9 Service Active Link

The link must:

- (a) Be the all insulated type.
- (b) Be fitted with a cover suitable for sealing.
- (c) Have a separate terminal for each conductor.
- (d) Have a current rating not less than the capacity of the incoming conductor.
- (e) Be located so that it is easily accessible and safe to work on.

- (f) Be identified to indicate they are "service active links" in a legible and durable manner in accordance with AS/NZS 3000.

Hinged panel construction may enable the link to be located on the rear of the panel, see AS/NZS 3000.

## 4.10 Service and Metering Neutral Links

The links must:

- (a) Be the all insulated type.
  - (b) Be fitted with a cover suitable for sealing.
  - (c) Have a separate tunnel terminal for each conductor which is clamped by not less than two screws.
  - (d) Have a current rating not less than the current carrying capacity of the associated incoming conductor.
  - (e) Be located so that they are not higher than 2.0m and not lower than 0.5m above the ground floor or platform. For special situations check with the distributor.
  - (f) Be identified to indicate that they are either a 'Service Neutral Link' or 'Meter Neutral Link'. Labelling must be legible and durable in accord with AS/NZS 3000.
  - (g) Hinged panel construction enables the service or meter neutral link to be located on the rear of the panel.
- i) The incoming main neutral conductor.
  - ii) The neutral connection to the customer's neutral link.
  - iii) A separate neutral conductor for each meter or load control device being installed.
  - iv) The operating coil of the controlled load contactor if provided.

An auxiliary sealable metering link must be provided if the service neutral link cannot terminate all the meter neutral conductors. The meter neutral link connection must be made using a minimum 4mm<sup>2</sup> copper conductor.

### 4.10.2 Meter Neutral Link

The meter neutral link must accommodate:

- i) The incoming main neutral conductor.
- ii) A separate neutral conductor for each meter or load control device being installed.

#### 4.10.1 Service Neutral Link

The service neutral link must accommodate:

## 4.11 Low Voltage Installations up to 100A per Active Conductor - Whole Current Metering

### 4.11.1 Whole Current Metering

Whole current meters must be protected by a maximum 80A current limiting (HRC) meter protection device. The electricity distributor may approve a circuit breaker as a combined SPD/MPD in some circumstances. The meter protective device must be located at the meter position.

The metering provider will specify the type of meters to be used.

Unless the metering provider specifies otherwise, ensure that:

- (a) The top edge of the meter is no more than 2.0 metres above the ground, floor or platform beneath the meter.
- (b) The bottom of the lowest meter is at least 0.5 metres above the ground, floor or platform beneath the meter.

Note: The 80 amp HRC fuse is to protect the Advanced Meter from damage due to through fault or substantial overload. Advanced Meters can tolerate cyclical loading up to 100 amps, short term overloads of up to 128 amps for 2 hours, and through fault currents of 3kA for half a cycle before being damaged. The 80 amp HRC fuse matches this protection requirement but can still carry 100 amps without operating.

Figure 4.4: Examples of Wiring Diagrams for Bottom Connected Metering

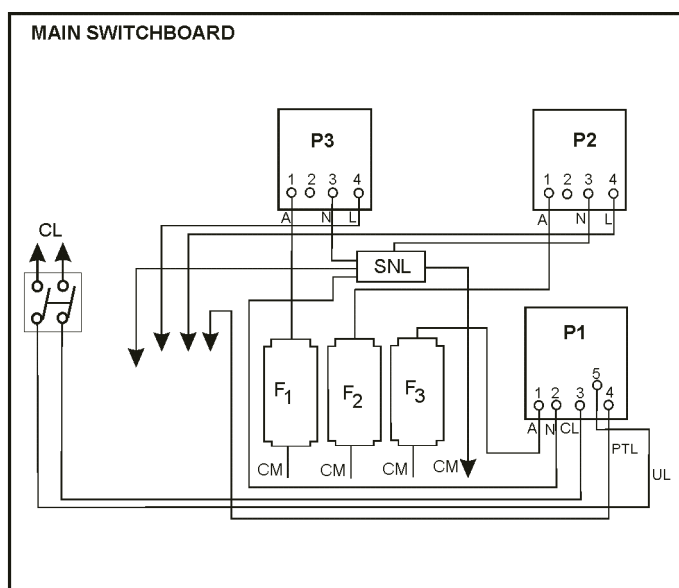

EXAMPLE THREE PHASE AND OFF-PEAK INSTALLATION (P1 IS AN ELECTRONIC METER)

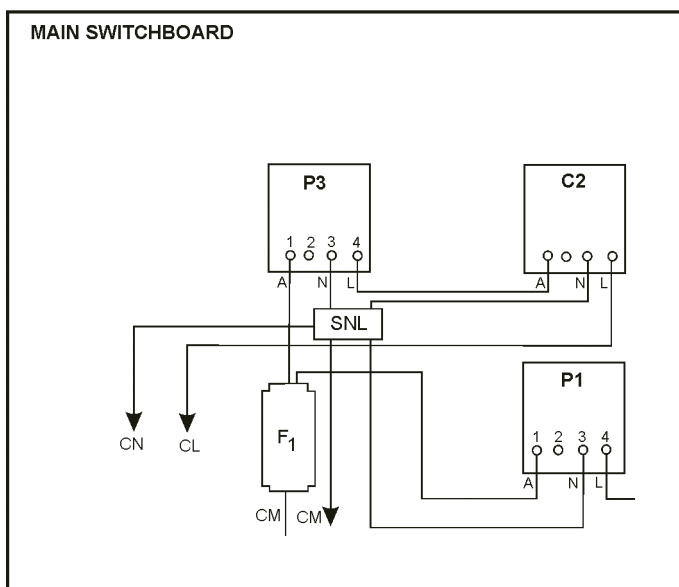

EXAMPLE SINGLE PHASE AND OFF-PEAK INSTALLATION BOTTOM CONNECTED DEVICES

**LEGEND**

- A Active terminal
- C Load-control device
- F Combined 80A SPD & MPD
- L Load terminal
- M Meter
- MC Controlled load meter
- N Neutral terminal
- SNL Service neutral link on back of panel
- P Positions
- PTL Principal Tariff Load
- P1 First position used in each layout
- CL Connection to controlled-load main switch or contactor
- CM consumers mains/underground service
- UL Uncontrolled Load

**Note:**

1. Panels hinged on the right hand side
2. The diagram indicates the line side as the bottom of the service protective device, therefore they must be labelled 'LINE SIDE' refer clause 4.7.6

**4.11.2 Bottom Connected Meters**

Where bottom connected metering exists, any additional meter/control equipment will also be bottom connected.

An example layout of bottom connected metering equipment and associated service equipment is shown in Figure 4.5.

Note: Care should be taken when stripping the cable to ensure the conductor strands are not damaged.

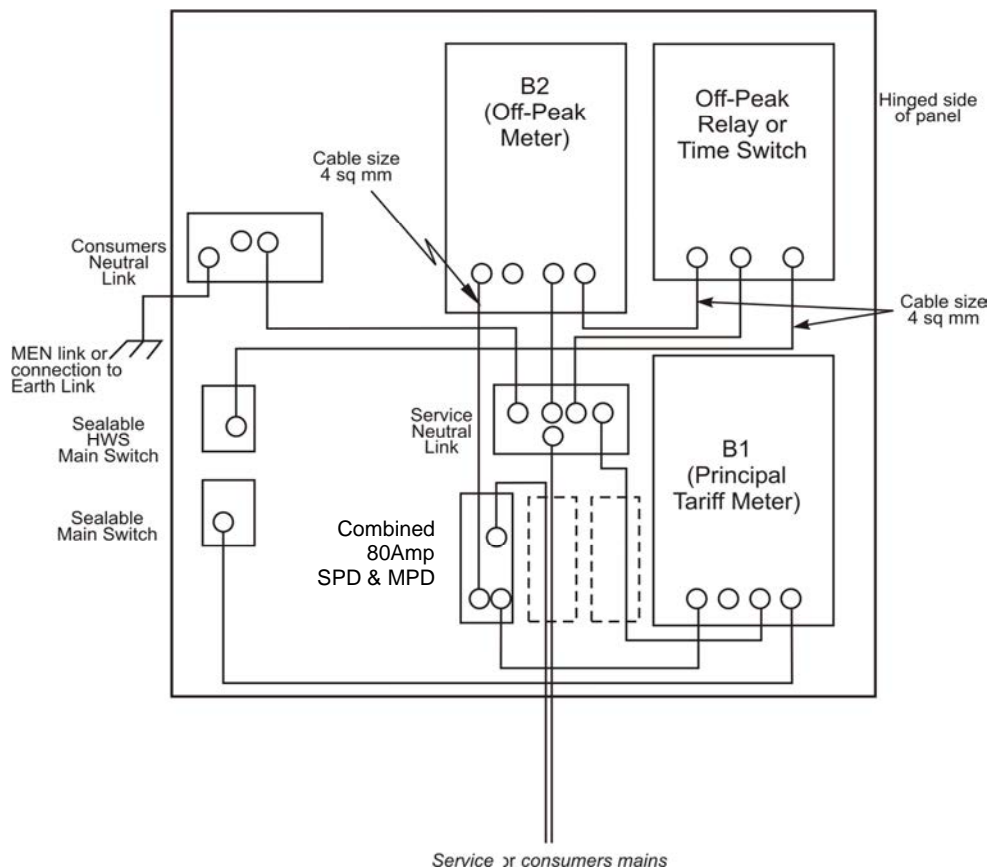
**Figure 4.5: Example Layout for Bottom Connected Metering**

Example shown is for a single phase customer with Off Peak

- Note:
1. The Service Neutral link may be mounted in any suitable location either on the front as shown or on the rear of a hinged panel.
  2. All equipment must be mounted no closer than 32mm from the hinged edge of the panel.

### 4.11.3 Load Control Equipment

Where electricity is to be supplied only during certain hours in accordance with the provisions of a published tariff, the electricity distributor may require the customer to provide and install a single pole load control device to directly control the load supplied under that tariff.

The electricity distributor will either provide or specify the type of load control device to be used.

Unless approved by the electricity distributor, controlled load must not exceed 25A single phase. Where the load exceeds 25A single phase or is inductive, the customer must provide, install and wire a contactor so that it is operated by the load control device. The contactor must be a non-latching type with provision for sealing and be installed at the metering position.

The contactor control circuit must be controlled and protected by a 10A circuit breaker which must be sealable. Refer to Figure 4.6. The neutral conductor for the contactor coil must be terminated in the service neutral link.

Other methods may be acceptable, apply to the electricity distributor.

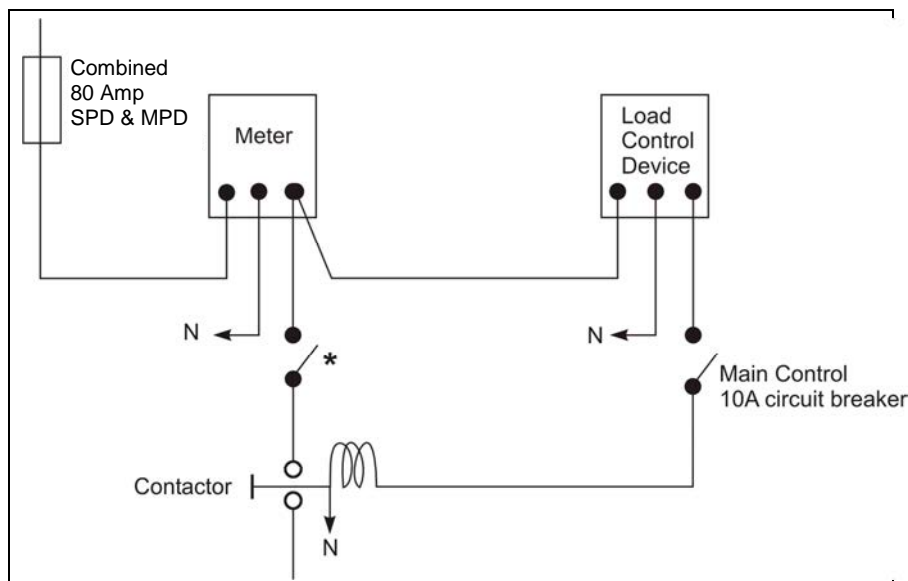
**Figure 4.6: Controlled Load - Contactor Wiring**

- Note: 1. The customer is required to install a contactor and associated wiring where the controlled load exceeds 25A or involves the switching of more than one phase of supply.
2. The contactor must be located at the meter position with a switch controlling the contactor coil.
3. The circuit breaker and contactor covers are to be sealable.
4. Single phase shown for clarity.
- \* An alternate location for the main switch may be on the load side of the contactor.

## 4.12 Connections at Service and Metering Equipment

The *customer* must arrange with an accredited service provider for the installation and connection of service equipment. If you use cables other than thermoplastic or elastomer-insulated stranded copper-conductor cable, you must joint the cables, or connect them in an approved manner, to a cable of the required type and size for connection to this equipment.

A single cable only is to be connected to any one terminal of service and meter equipment.

For installations containing twin element off-peak water heaters, or a contactor as per clause 4.11.3 two cables may be connected into the meter load terminal.

The two cables must be twisted together.

Where there is the need to connect more than one meter to one phase of an unmetered supply or sub main, use links to arrange the circuits connected to the meters.

Install meter wiring of not less than 4mm<sup>2</sup> on the load side of the service protection fuses and service neutral link. The wiring must be suitable for the maximum demand that it will carry.

If two load terminals are provided in the service protection fuse, you may connect an additional cable to supply a separately metered portion of the installation. Where more than two portions of the installation have to be supplied from one service protection fuse, you must provide and install a suitable, sealable service active link.

### 4.12.1 Cable Preparation and Termination

Manufacturer's guidelines are to be adhered to with regard to the preparation and termination of cables into service and metering equipment.

All cables connecting to service and metering equipment must be prepared and terminated in the following manner.

- Only a single conductor per terminal is permitted
- Single cables with a cross sectional area of less than 10mm<sup>2</sup> must be twisted and doubled over
- Soldering is not acceptable Cables must be adequately secured under all available termination screws.
- There must be no more the 1mm of exposed conductor protruding from any termination where located under a sealed enclosure.

#### 4.12.2 Maximum Conductor Sizes for Services Rated to 100A

The maximum total conductor cross-sectional area which is permitted to be terminated directly at meters and 100 A service or metering protection fuses shall not exceed the design of the terminal

#### 4.12.3 Flexible Switchboard and Panel Wiring

Flexible switchboard and panel wiring may be used to connect service and metering

equipment, provided it is installed in accordance with the manufacturer's specifications.

### 4.13 Provision of Isolation of Customer Installations

#### 4.13.1 Whole Current Metering

In installations where whole current metering is used, a control device must be provided on the load side of the meter and load control equipment at the meter/switchgear enclosure to enable each individual tariff to be isolated and sealed.

The means of isolation:

- The switch toggle must be sealable in the open position in an acceptable manner such as with nylon/plastic sealing wire, not less than 1.4 mm in diameter, refer to Figure 4.7.
- May comprise the customer's main switches or protective devices (one switch per tariff) refer to Figure 4.9.
- Must be an independent device, or group of devices, for each customer, in particular for customers in multiple installations.
- Emergency services (eg lift and fire services) may require an additional main switch, and be a 3 phase switch where 3 phase equipment is installed. Refer to AS/NZS 3000.

Figure 4.7: Sealable Circuit Breaker

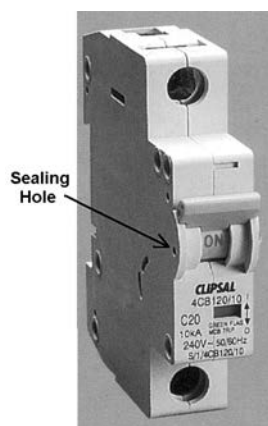

#### 4.13.2 Current Transformer Metering

A sealable or lockable isolation device must be provided for CT metered installations. This isolation device is to be located on the line side of the CTs and allows each individual tariff and / or customer to be isolated. An appropriately rated circuit breaker is a suitable device for this purpose.

**Figure 4.9: Example of isolation provision for whole current metering**

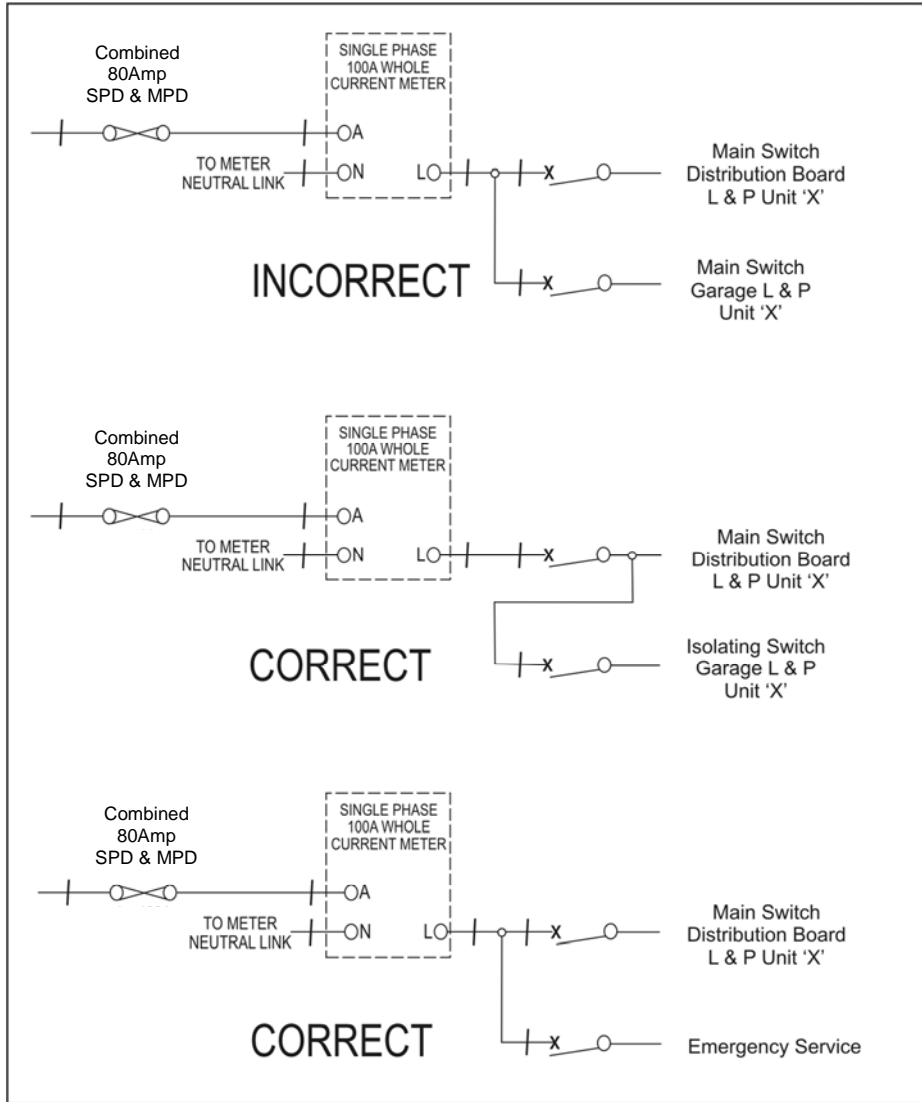

Note: Emergency services may require an additional main switch.



## 4.14 Multiple Installations

Examples of multiple installations are:

- (a) Multiple residential installations which include: a number of single domestic installations. Single domestic installations include a flat, unit or duplex unit
- (b) Groups of small shops and/or offices
- (c) Shopping malls
- (d) Factory units
- (e) Combinations of the above.

For large multiple installation developments, contact the electricity distributor as early as possible to prevent delays for connection of electricity.

The customer must provide for supply to each separately metered portion of an installation that is supplied from a single PCC.

If the main switches have to be installed on the line side of the service protective device (before or after the upstream active links) the main switches must be rated to withstand the nominal short circuit currents.

### 4.14.1 Meter Protection Device

Meter protection devices must only protect a single metered installation. Refer Table 4.1.

### 4.14.2 Arrangement of Metering Neutrals

Each metering device must be supplied by a separate neutral conductor. The neutral conductor must be connected to a separate terminal of the service neutral link, or an additional neutral link which will serve as a meter neutral link.

### 4.14.3 Paralleling Links

A customer may install paralleling links to facilitate changes to metering arrangements.

The links must be readily accessible as defined by AS/NZS 3000 and provided with sealing facilities. Customer's equipment must not be located behind CT compartment access door or cover.

Each paralleling link and connecting cable must be labelled to identify the particular portion of the installation connected to it. All paralleling links must be arranged in a single group, on a panel in close proximity to the associated meter group.

### 4.14.4 Mounting Provisions for Meters

Switchboard panels hinged, fixed or removable must be non-metallic, comply with AS/NZS 3000.

### 4.14.5 Unmetered Submains

The customer is to provide facilities for sealing or locking of all covers etc, providing access to unmetered equipment. The customer must be able to replace any unmetered fuse link or operate circuit breakers without the removal of the seal or lock.

The customer is responsible for the cost of such locks which will remain the property of the electricity distributor.

Refer to clause 4.16 for sealing details.

### 4.14.6 Labelling

For multiple installations, meter panels must be clearly and permanently labelled to indicate occupancy identification in accordance with clause 4.21 for all equipment to be mounted on the panel.

### 4.14.7 Metering Equipment Requirements

Refer to the accredited service provider, electricity distributor or metering provider for space and metering equipment requirements.

*Figure 4.10: Deleted*

*Figure 4.11: Deleted*

*Figure 4.12: Deleted*

**Figure 4.13: Typical Arrangement of Multiple Installations using Unmetered Mains, Submains and Switchboards**

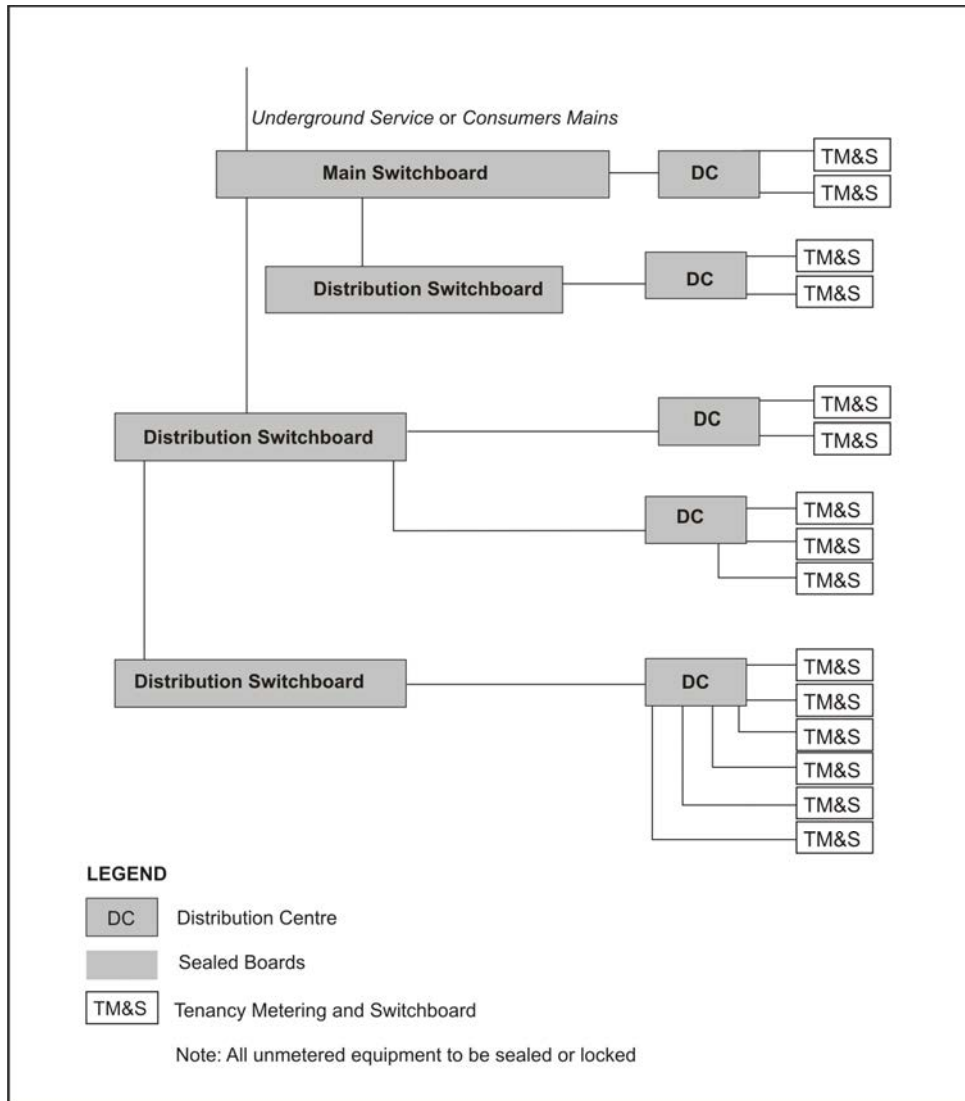

## 4.15 Spacing Between Metering Equipment and High Current Conductors

External magnetic fields may damage metering equipment. The following minimum spacings between metering equipment and current carrying conductors must be provided and maintained.

### 4.15.1 Multicore and Bunched Single Core Cables

No special requirement for spacing is needed where the separation between all conductors of a circuit is due solely to the solid insulation and sheathing on the conductors, (eg, multicore cables or a group of single core cables in flat or bunched formation).

### 4.15.2 Spaced Single Core Cables, Busway or Busbars

Where the separation between conductors of the same circuit exceeds that in clause 4.15.1 but does not exceed 160mm, refer to Table 4.2.

**Table 4.2**

*Maximum Current in Conductor Nearest to Meter (A)	Minimum Spacing between Conductor and Meter (mm)
150	Nil
200	100
400	500
600	700
1000	900
1500	1200
2000	1400
3000	1700
4000	2000

\*The maximum current in the conductor is determined by the AS/NZS 3000 maximum demand for consumers mains and submains.

Table 4.2 gives the minimum spacing between any point on the metering equipment and any point on the nearest conductor of the circuit. Calculate the intermediate measurement proportionally.

### 4.15.3 Shielding

Spacings determined under clause 4.15.2 may be reduced if the meters or conductors are mounted within a suitable shielding enclosure. Determine the spacing by multiplying the value from clause 4.15.2 by a factor. Table 4.3 indicates the multiplying factors for various thickness of mild steel. If other thicknesses or materials are proposed, the electricity distributor will determine the factor.

**Table 4.3**

Thickness of Mild Steel Plate (mm)	Multiplying Factor
5.0	0.25
2.5	0.5
1.2	0.75

Eg using a 1.2mm thick shield reduces the minimum spacing between a meter and a 4000A conductor from 2m to 1.5m (spacing)  $2000 \times 0.75$  (multiplying factor) = 1.5m.

### 4.15.4 Special Cases

Avoid spacings in excess of 160mm between the centres of conductors of a circuit near meters. If you can't do this, submit the details in writing to the metering provider, who will determine the spacing requirements from the metering equipment for you.

Some types of meters may not need the listed requirements which may be waived by the metering provider.

## 4.16 Sealing of Service and Metering Equipment

**Security seals MUST not be removed by persons without authorisation/permission from the owner of the seal.**

**Where seals are broken, the entity that has broken the seal is responsible for arranging the resealing upon completion of work.**

All service and metering equipment, unmetered links and paralleling links must be sealed in an approved manner. Nylon/plastic sealing wire will generally be used.

Seals on a service protection device that are broken must be re-sealed by an authorised person. This may be a metering provider, Level 2 authorised person/electricity distributor. A charge may apply.

The customer must suitably enclose and provide for sealing of all equipment installed on the line side of the meters, and all metering connections.

Note: Some distributors may require sealing by locking, check with the distributor.

This clause is not intended to prevent Metering Providers from removing and replacing seals in accordance with national metrology requirements and procedures.

### 4.16.1 Multiple, Single and Large Installations

The customer's qualified representative must be able to replace ruptured unmetered fuses, without electricity distributor staff attending to remove seals and reseal equipment. Sealable escutcheon panels may be used with either front or back connected fuses or circuit breakers to allow this.

Individual items of equipment such as unmetered links must be sealed. In some cases it may be better to provide a sealable cover or panel over equipment which the customer does not need to access for maintenance.

## 4.17 LV Current Transformer Metering

Where the assessed load of an installation or portion of an installation to be separately metered exceeds the current rating of the metering equipment, the metering provider will require that the meter be a current transformer (CT) type

The customer must provide the facilities for the mounting and connection of the current transformers, meters and associated equipment in accordance with these Rules.

The customer is responsible for the provision and installation of:

- (a) All equipment mounting facilities.
- (b) Meter panels pre-drilled and installed.
- (c) Voltage circuit fuses (10A current limiting (HRC)) suitable for sealing.
- (d) Meter links - used for metering purposes where the service neutral link cannot accommodate all the neutral cables associated with metering.
- (e) All cabling to the specified identification code fully connected to the equipment.
- (f) The CTs.
- (g) The meter test block - used to allow in circuit testing of CT metering systems.
- (h) The meters and their connection.

The metering provider will specify:

- (a) The type of CTs.
- (b) The meter test block.
- (c) The meter equipment to be provided.

### 4.17.1 Submission of Design

The customer must submit full details of the proposed installation for examination before the relevant work proceeds to prevent possible delays in the connection of electricity.

The submission must include:

- (a) The proposed load details.
- (b) The design of the CT enclosure.
- (c) A single line schematic diagram.
- (d) Power Factor correction **if applicable**.

The metering provider will not normally comment on the design of an electrical installation unless a fee is paid by the customer. Check with the metering provider.

The design will be assessed for tariff and metering requirements.

Note: Not all of requirements of this section apply to LV switchboards in installations supplied and metered at high voltage. However, it is recommended that the principles of this document be applied to these switchboards.

### 4.17.2 Prospective Short Circuit Current

The electrical installation must be capable of withstanding, without damage, the nominated prospective short circuit current.

Switchboards and equipment rated greater than 400A must be rated for the nominal prospective short circuit current for 1 second. The electricity distributor will provide values not specified in these Rules upon application.

### 4.17.3 Protection Grading

Select and arrange your main circuit breakers or fuses so that they will interrupt the fault current in the event of a fault on the portion of the installation they protect. They must interrupt the fault current rapidly enough to ensure that the electricity distributor's protection devices do not operate.

The electricity distributor will provide information on the characteristics of the electricity distributor's protection equipment.

#### **WARNING**

**Where a single customer is supplied direct from a substation the electricity distributor generally protects its equipment by the installation of a circuit breaker or fuse in each outgoing LV circuit.**

**Unless the customer's protective devices are correctly selected to discriminate with the electricity distributor's device, a fault within the electrical installation may cause the device to operate.**

**The implications of this are as follows:**

**Supply to smoke and fire control and emergency evacuation equipment and lifts may be interrupted. It is common for such faults to occur during fires when the need for emergency supply is paramount.**

**Resetting of 'tripped' equipment can only be carried out by the electricity distributor's specialised staff and this may cause considerable delay to the reconnection of supply. It may also incur a charge.**

### 4.17.4 Whole Current Metering

Where it is necessary to meter other sections of the premises using whole current meters, the take-off PCC to the meter protection devices must be on the line side of the CT metering. It is not permitted to have the PCC on the load side of a CT and pass cables through the CT in the reverse direction.

Where the primary conductor is an insulated cable, sealable links must be used. The wiring to the meter protection device must be connected at these links.

The meter protection device must:

- (a) Be located in that section of the enclosure allocated for the electricity distributor's use.
- (b) Be mounted either on the busbar or on an adjacent insulating panel.
- (c) Be capable of being withdrawn towards the operator.
- (d) Not impede access to the metering current transformers or other equipment.
- (e) Be sealable in accordance with clause 4.16.

#### 4.17.5 Current Transformer Facilities

Metering CTs must be:

- (a) Mounted in a suitable enclosure segregated from the meters and switchboard equipment.
- (b) Installed on the **load** side of the service protective device.

For installations and separately metered portions of installations with maximum demands greater than 400A per phase the metering CTs must be installed within a cubicle type switchboard. Refer to Figure 4.15.

Attention must be paid to additional space requirements to terminate large conductors.

**Figure 4.14: Deleted**

**Figure 4.15: Typical CT Installation in a cubicle type switchboard**



Note: Shown without safety screen. Refer to clause 4.17.6.

#### 4.17.6 CT Enclosure - Construction

The CT enclosure when forming part of a cubicle switchboard must be constructed so that a tool or article accidentally dropped by a person working on the connections cannot fall from the CT compartment into other areas of the switchboard.

CTs should be segregated from other equipment. No part of the electrical installation, including any measuring instruments and control devices, is permitted within the CT enclosure, except the customer's measurement current transformers.

Do not mount the customer measurement transformers on the removable section of the busbar provided for the metering transformers or impede access thereto.

For other situations apply to the metering provider.

These requirements also apply to the unmetered sections of a cubicle type switchboard.

All live conductors within 300mm of the secondary terminals, voltage circuit fuses and metering neutral link must be insulated or screened to prevent inadvertent contact. Convenient access is required for removal of CTs. These requirements may be met by the provision of a removable screen of light insulating material with openings shaped to fit over the CT secondary terminals and associated wiring. The secondary terminals, voltage-circuit fuses and metering neutral link must be accessible without removal of the screen. Where a screen is used it must be fitted with two insulated handles and be secured to the switchboard.

#### 4.17.7 Vermin Proofing

All entries to the CT compartments/enclosures should be fitted with suitable gland plates, barriers etc, to prevent pests from entering.

#### 4.17.8 Doors and Access Cover

Provide doors and access covers that are easy and safe to open or remove. If they are hinged, they must be capable of opening to 90° minimum.

Access covers must not be greater than 1 square metre in area. The length must not exceed 1500 mm. Fit a handle to each side of the cover, slightly higher than its horizontal centre line.

Provide fixings so that the cover remains in position when the fasteners are released or removed.

#### 4.17.9 Identification of Enclosures

The customer must provide identification for the CT metering enclosure.

The cover, whether hinged or removable, must:

- (a) Be marked "Accredited Metering Provider Metering CTs Enclosed".
- (b) Clearly identify the customer.
- (c) Identify the relevant tariffs, if more than one tariff is involved.

Fix a similar label adjacent to the CTs.

#### 4.17.10 CT Security Locking or Sealing

The CT compartment and unmetered sections of a switchboard/installation must be sealed or locked as follows:

- (a) The CT access covers and unmetered sections must be appropriately secured where located outdoors or remote from the meter position. This can be achieved by lockable doors that are secured with appropriate accredited metering provider locking system and sealed access covers. The customer can lock to add extra security to prevent unauthorised operation..
- (b) The CT access covers and unmetered sections may be sealed where located within a building.

The sealing facilities must be designed so that they can be sealed with short lengths of sealing line.

Provide sealing for:

- (a) **A door** - at the side of the door opposite to its hinged edge.
- (b) **A removable cover** -at two approximately diagonally opposite points on the cover.

#### 4.17.11 CT Location and Access

Locate CTs, removable busbars, voltage-circuit fuses, and neutral links so that they are:

- (a) More than 500mm.
- (b) Less than 2500mm

from the ground floor or platform of access.

#### 4.17.12 Voltage Circuit Protection

The customer must provide and install all the links and the voltage circuit protection fuses.

All fuses must be:

- (a) a 10A current limiting (HRC) fuse type NS to AS 60269.3.0 and AS 60269.3.1, in an enclosure with class IP2X to AS 1939 'Degrees of protection provided by enclosures for electrical equipment (IP Code)', or
- (b) a Class G current limiting (HRC) fuse links in a modular fuse holder complying with IEC 269 - Part 2.

A 10A current limiting (HRC) fuse link must be installed in either option.

Fuses must be suitable for sealing the fuse-link holder to the base. You can provide a sealable cover over all the fuse assemblies. The fuses should be installed so that they are extracted away from the face of the panel and towards the operator.

**WARNING**  
**Remove the fuse links from the fuse link holders and tie them nearby. Insert the holders into the fuse bases. The authorised person will install the fuse links when commissioning the metering installation.**

Mount the voltage circuit fuses on a panel of insulating material. They must be located in an accessible position to enable their safe withdrawal whilst the supply is energised and be as close as practicable to the current transformers that they are associated with.

Provide a clearance of between 100mm (minimum) to 300mm (maximum) between the panel and the enclosure door.

Alternative forms of voltage circuit fuse mounting include:

- (a) "DIN" rail.
- (b) Securely fixed on a steel bracket provided the mounting screw hole is covered with a suitable insulating material.

#### 4.17.13 Current Transformers

The CTs must comply with Chapter 7 of the National Electricity Rules. Figure 4.16 details the dimensions of the various CTs available.

Where the metering provider does not provide the CTs, the customer must provide the metering provider with test results in accordance with Chapter 7 of the National Electricity Rules.

**WARNING**  
**Never open-circuit the secondary terminals of a CT while the primary winding is energised because a very high voltage will be induced. This voltage is likely to give the person working on it a severe electric shock and cause damage to the CT insulation.**

The secondary terminals of the CTs are to be short-circuited to prevent inadvertent damage and shock. The bridges are to be removed when commissioning the metering installation.

Retain the short-circuit of the secondary terminals when connecting the secondary current conductors, if supply is connected.

The CTs must be mounted with the polarity marks P1, L or a distinctively coloured dot adjacent to the terminals facing the incoming supply. The operating range of extended range current transformers must not be exceeded.



Figure 4.16: Current Transformer Details

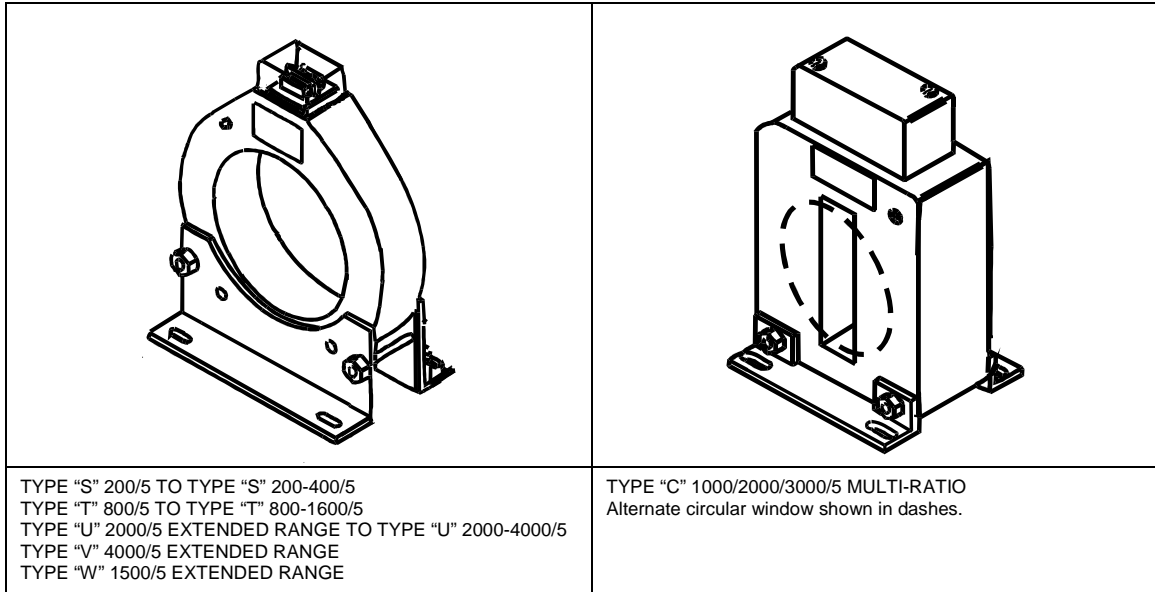

TYPE "S" 200/5 TO TYPE "S" 200-400/5  
 TYPE "T" 800/5 TO TYPE "T" 800-1600/5  
 TYPE "U" 2000/5 EXTENDED RANGE TO TYPE "U" 2000-4000/5  
 TYPE "V" 4000/5 EXTENDED RANGE  
 TYPE "W" 1500/5 EXTENDED RANGE

TYPE "C" 1000/2000/3000/5 MULTI-RATIO  
 Alternate circular window shown in dashes.

Notes	Current Transformer dimensions. See table below.
1. Chapter 7 of the National Electricity Code specifies the type of CTs to be used.	
2. Before proceeding with the manufacture or design of any switchboard assembly, requiring the use of metering current transformers, reference should be made to the electricity distributor.	
3. Alternate mounting height of type "S", "T" and "U" current transformers may be available from the electricity distributor. When allowed the feet may be assembled to provide alternative heights "H1" and "H2" between the mounting surface and the centre line of the CT. Opening (dimension "C") maximum height "H2" must be used if busbars pass through opening unless stated by electricity distributor.	
4. Polarity. Unless stated by the metering provider, each current transformer is to be provided with polarity marks. The transformer must be installed with the polarity marks P1 L or coloured dot facing the direction of the incoming supply. Refer to clause 4.17.13.	

CTs Commonly Used			
DIMENSIONS	TYPE 'S-45'	TYPE 'T'	TYPE 'W'
A	115	155	165
B-MOUNTING HOLE CENTRES	75	75	75
C	DIA 45	DIA 85	DIA 112
D	54	60	60
E	53	53	53
F	114	165	165
G	55	59	59
H SEE NOTE 3	65 85	85	87 115
J SEE NOTE 3	130 150	175	175 200
K SEE NOTE 3	163 183	210	210 236
L-MOUNTING HOLE CENTRES	80	80	80
M	102	107	107
WIDTH OF MOUNTING SLOT	10	10	10

CTs which may be available, consult Electricity Distributor							
TYPE 'S-SE'	TYPE 'S'	TYPE 'T-SE'	TYPE 'U-SE'	TYPE 'U'	TYPE 'V'	TYPE 'C-SE'	TYPE 'C'
125	115	160	240	240	275	156	156
75	75	75	190	190	225	114	114
DIA 35	DIA 32	DIA 95	DIA 170	DIA 170	DIA 178	Width 35 Height 137	DIA 112
48	48	48	48	48	48	49	49
53	53	53	53	53	53	112	112
110	110	165	254	250	308	162	162
50	55	55	55	55	62	70	70
H1-50 H2-80	80 65	80	130	130	154	105	105 115
J1-110 J2-145	150	185	270	270	325	212	212
K1-145 K2-180	180	210	310	310	370	264	264
80	80	80	125	125	132	95	95
105	105	105	160	160	162	122	122
10	10	10	10	10	10	10	10

**Figure 4.17: Mounting of Current Transformer Switchboards - General Requirements**

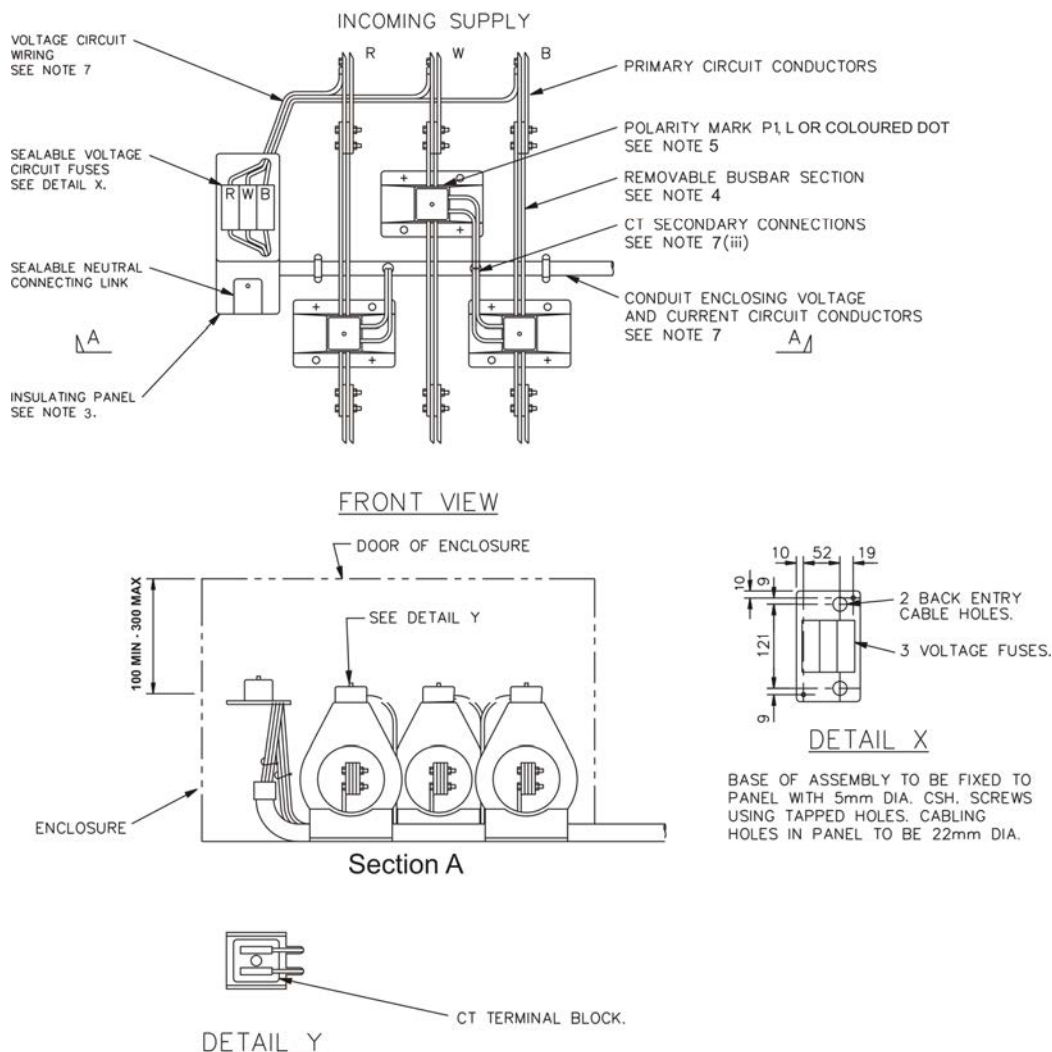

Notes to Figure 4.17

1. This is a typical arrangement of equipment showing how the requirements may be met.
2. Location and access requirements are covered in these Rules.
3. The customer is to supply and mount the voltage circuit fuses and a sealable metering neutral link (if required) to be fixed on a supporting panel.
4. The requirements for the installation of primary circuit conductors passing through the CTs are covered in clause 4.17.15.
5. Each current transformer is provided with polarity marks. The transformers must be installed with the polarity mark P1, L or a coloured dot facing the direction of the incoming supply.
6. The CTs may be staggered as required. The incoming supply may be from any direction.
7. Wiring.
  - (i) All wiring for metering purposes must be installed and connected by the customer's contractor. Under normal circumstances, the switchboard will not be energised until approved by the electricity distributor.
  - (ii) The insulated and sheathed cables between voltage circuit fuses, meter neutral link and primary circuit conductors must be adequately supported. The requirement for sheathing may be met by using PVC insulated cable enclosed in 6mm diameter clear PVC tubing with a wall thickness of 1.5mm. Apart from the connections a clearance of 25mm (min) must be maintained from the busbars apart from the connection.
  - (iii) The current circuit cables must be supported between the conduit and terminal blocks by tying them together. The CT meter circuit cables are to be colour identified or numbered.
8. Safety screen when used is not shown in Figure 4.17.

#### 4.17.14 Mounting of Current Transformers

The customer must provide the mountings for the CTs.

The mountings may use fixed studs or threaded holes tapped in a suitable mounting plate. Dimensions for the mounting centres are shown in Figure 4.16.

Where the primary conductor is a busbar the CT mounting plate may be adjustable to allow for the different mounting heights of the CT suitable for the maximum current rating of the switchboard.

The mountings must consist of 6mm (min) to 9mm (max) diameter studs, secured by brazing, or equivalent means, to a mounting plate or bar, together with nuts.

Alternatively, threaded holes at two diagonally opposite corners of a mounting plate, and slotted or hexagon-headed set screws with a diameter of between 6mm (min) to 9mm (max.) are acceptable. In this case, provide dowels at the other corners to support the CTs while the set screws are removed.

Two methods of mounting current transformers are acceptable, these are:

- (a) In-line where the bodies of each CT are in one line.
- (b) Staggered where the centre phase CT is offset from the other two.

Refer to Figure 4.17 for details.

#### 4.17.15 Primary Conductors

Provide a removable section of busbar through each CT.

Do not connect any wiring to the removable section of the busbar or the bolts or fixings which secure it.

Select the size and shape of the busbar to suit the openings in the type of CTs specified by the electricity distributor or Metering Provider.

The length of the removable section of busbar must be:

- 300mm (min) to 450mm (max) in length for CT types A, B, C, S, T and W.

Alternatively you can use an insulated cable as the primary conductor passing through each CT. Arrange the cable so that the CT can be removed. Do not use more than 1000mm of cable from the CTs to the location of the line side cable connection.

The surfaces to which these conductors will be connected must be either copper or suitably plated copper or copper alloy. They must be free of any painting, coating or covering.

You must be able to connect and disconnect the CTs without using any tools except an adjustable or socket type spanner.

#### 4.17.16 Cubicle Switchboard enclosed Current Transformers

The following additional requirements apply when CTs are installed in a cubicle type switchboard.

The switchboard manufacturer must submit drawings to the metering provider including the location of metering CTs. The equipment must be readily accessible from the outside of the cubicle.

Connections to the:

- (a) CT secondary terminals.
- (b) Voltage circuit fuses.
- (c) Meter neutral link

must not be more than 300mm from the plane of the access panel or doorway.

The cubicle or section of the switchboard allocated for the metering provider's use must be separated from the customer's portion of the switchboard by means of a suitable barrier(s).

No part of the electrical installation is permitted within or on the metering provider's section of the switchboard except as permitted in clause 4.17.6.

The metering provider may require arrangements for an inspection of the switchboard at the switchboard manufacturer's premises.

This is a preliminary inspection and a final inspection will be made when installed on site.

Access arrangements must also comply with clause 4.2.

#### 4.17.17 Connection of Neutral Links

Conditions for the location of the MEN connection are:

- (a) It must be located, so that it can be readily and safely removed whilst the supply is connected.
- (b) It must be located within the customer's section of the switchboard.
- (c) An appropriate notice must be fixed to the switchboard indicating the location of the MEN connection.

Where a switchboard consists of one assembly and is provided with multiple supplies the neutral bar and earth bar must be electrically continuous throughout the assembly.

Where a switchboard consists of more than one assembly, located in the one switchroom, and is provided with multiple supplies:

- (a) You must provide an MEN connection in each separate assembly.
- (b) You must make the earthing system of the installation common to all assemblies.
- (c) If you install a bus-section coupler:
  - i) The MEN connection must be made on only one assembly;
  - ii) The common neutral must join each switchboard neutral bar;
  - iii) The neutral bars must have current carrying capacity not less than the underground service/consumers mains neutral conductor;

in case there is feed-back through the earth-neutral system.

#### **4.17.17.1 Railway Land**

Electrical installations on railway land in the 1500V dc electrified rail track area uses a modified direct earthing system which incorporates a reticulated insulated earthing conductor. This system requires the neutral and earth to be insulated from each other, hence no multiple earth neutral (MEN) connection is permitted, except for the one and only connection for each supply made by the party nominated in ST publications.

Note: In certain circumstances this connection may be located on the consumers main switchboard. Refer to clauses 1.16.14 and 1.16.7.1.

#### **4.17.18 Earthing**

The electrical installation main earth is not normally directly connected to the electricity distributor's earthing system.

Written acceptance from the electricity distributor is necessary before such an arrangement may be carried out.

##### **4.17.18.1 Railway Land**

Refer to clauses 1.16.14 and 1.16.7.1 for earthing of electrical installation on railway land in the 1500V dc electrified track area.

#### **4.17.19 Stand-by Supply Equipment**

Main switches and changeover devices to connect a stand-by generating plant must comply with all requirements of Section 8 - Alternate Source of Low Voltage Supply of these Rules.

Where stand-by supplies exist that are controlled by automatic changeover equipment, the following conditions apply:

- (a) The main isolator of each stand-by supply must be able to be locked in the open position.
- (b) The control circuitry must be designed to prevent operation of the main isolator, due to the loss of the other supply, when it is locked open.
- (c) The changeover equipment must be preceded by a manually operated load break isolator.

## 4.18 Meter Panel Location and Access for CT Metering

The customer must provide and install a hinged meter panel where CT metering is required. The meters and their associated equipment for each separately metered part of the installation must be kept together.

Locate the meter panel so that:

- (a) The height of the top edge of the meter above the ground, floor or platform level is not more than 2 metres.
- (b) The bottom of the lowest part of metering equipment is at least 0.6 metres above the ground, floor or platform except where otherwise approved by the metering provider.

Provide a minimum clearance of 175mm from the face of the hinged panel to the inside face of any enclosure.

Provide a minimum distance of 200mm from the face of the panel to any fixed object when the panel is open 90 degrees on its hinges.

The metering panel must not be installed in a location subject to high intensity magnetic fields. The minimum spacing between meters and current carrying conductors set out in clause 4.15 must be provided and maintained.

The requirements set out in this Section for service and metering equipment will also apply to the installation, grouping, accessibility, location, and protection of CT meter equipment and meter panel.

### 4.18.1 CT Meter Panel

The customer must provide a meter panel (550mm X 550mm) or greater for a single metering installation (which includes check metering when required).

The panel must:

- (a) Be of suitable insulating material.
- (b) Be hinged on the left or right hand side.
- (c) Be mounted on a surround made of 1mm (min) zinc coated steel to provide a clear depth of 75mm (min) behind the panel.
- (d) Be pre-drilled to suit the installation of the proposed metering instruments.
- (e) Only CT metering and associated equipment is permitted on this panel.

The panel may form part of the main switchboard.

Any door fitted to a metering enclosure must be labelled "Electricity Meters".

## 4.19 Facilities for Connection of CT Metering Equipment

Figure 4.18 shows a typical wiring diagram for CT metering.

The customer must provide and install all wiring necessary between the CT position and the CT meter for each separately metered part of the installation. Provide sufficient length to make the connections to the meters.

Insert 75mm of cable through the appropriate holes in the meter panel and bare 20mm of insulation from the ends.

The wiring must be 0.6/1 kV, PVC insulated, stranded copper conductor of cross sectional area as shown in Table 4.4. Each of the insulated conductors must be visually distinguishable by size, colour and/or number marked on the insulation at regular intervals throughout its length. Refer to Table 4.4.

Sheathing of the voltage and CT secondary cables is required by AS/NZS 3000 and AS/NZS 3808 Insulating and Sheathing Materials for Electric Cables. Clear PVC tubing with a wall thickness of 1.5mm may be used to make the identification visible.

The conductors must be:

- (a) Single insulated conductors enclosed in conduit, or

- (b) Multi-core cables.

Do not include any wiring for purposes other than the current and voltage circuit wiring in the conduit or sheath protecting this wiring, with the exception of the earth conductor for earthing the meter enclosure.

The conduit or cable(s) must be open to view, unless the electricity distributor approves otherwise.

### 4.19.1 Protective Enclosure

Wherever possible, the protective enclosure for the voltage and current circuit wiring should be:

- (a) A surface-run PVC conduit, or
- (b) The plastic sheath of multicore cable.

The conduit or sheath must be installed in accordance with AS/NZS 3000.

Where surface-run wiring is not practicable or additional protection is required the cable must be installed in heavy duty UPVC conduit.

Where installed underground the conduit must be laid at a depth of 500mm except where encased in concrete.

**Figure 4.18: Typical Wiring for Current Transformer Metering**

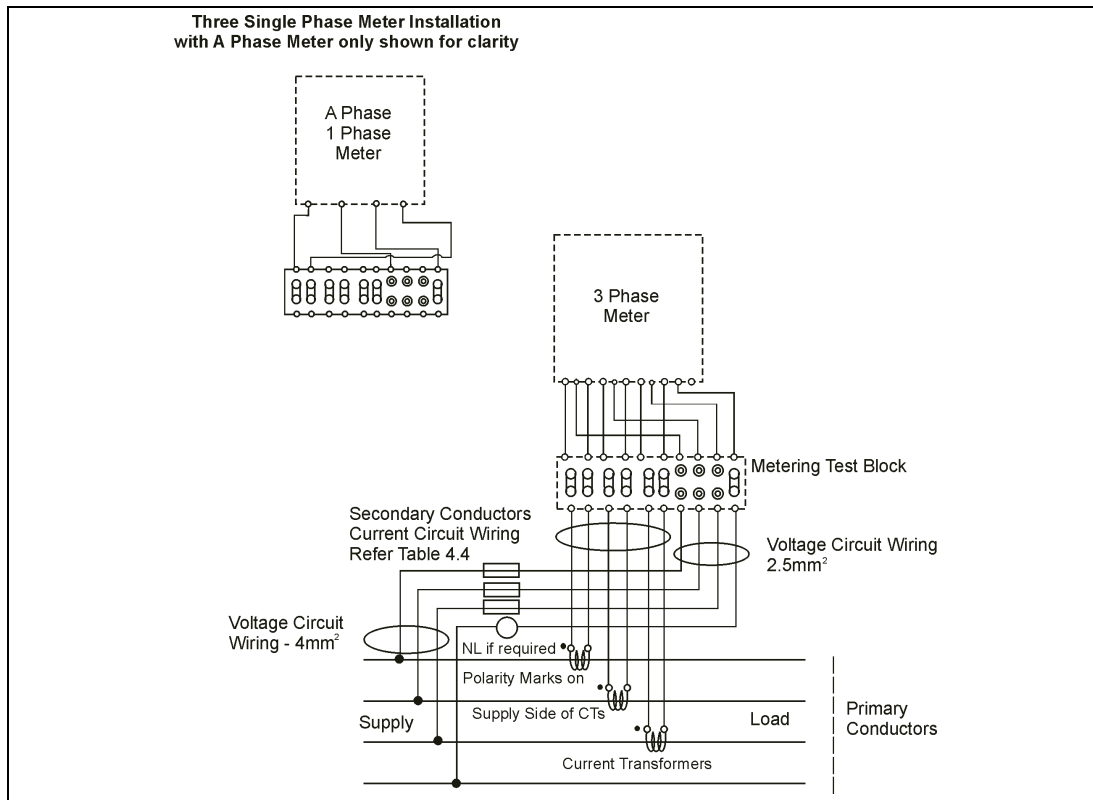

**Table 4.4: Identification Coding of Cabling for CT Metering**

Use	Size	Circuit	Identification Code		No. of Conductors	Installation
			Option 1 (Colour)	Option 2 (Numbering)		
Voltage Circuit (Fuse to Test Block to Meter)	2.5 mm <sup>2</sup> (no limit on route length)	A phase B phase C phase Neutral	red white blue black	7 8 9 10	4 per CT metered position (includes a neutral)	Single cables in common conduit with current circuit cables or 1 multicore
Current Circuit (CTs to Test Block to Meter)	Refer to Table 4.5	A polarity A non-polarity B polarity B non-polarity C polarity C non-polarity	red black white orange blue grey	1 2 3 4 5 6	6 per CT metered position	Single cables in common conduit with voltage circuit cables or 1 multicore.
Earthing	2.5 mm <sup>2</sup> (no limit on route length)		Green/yellow	Green/yellow	1 per CT metered position	With voltage circuit or separately with cable run
Summation Equipment	1.5 mm <sup>2</sup> (no limit on route length)		coloured or numbered	coloured or numbered	6 per remote CT metered position	Single cables in conduit or 1 multicore
Contactor Control Wiring	2.5 mm <sup>2</sup>		red or black	red or black	1 per CT metered position	Twin cables in one sheath

Notes to Table 4.4:

1. Voltage circuit wiring in Figure 4.20
2. All cables must have stranded copper conductors.
3. Where Option 1 identification code of cables is used the current circuit cable size cannot be the same as the voltage circuit.
4. The voltage and secondary current circuits are to be numbered or colour coded throughout their entire length.

### 4.19.2 Current Circuit Wiring

The customer must install six CT secondary current circuit conductors between the CTs and the meter panel (see Table 4.4).

The cross-sectional area required for the CT secondary circuit conductors is dependent upon:

- (a) The route length of the wiring between the meter panel and the CTs.
- (b) The transformer characteristics.

It must not be less than that shown in Table 4.5.

Note: Existing 4 wire current circuit wiring systems do not require upgrading to a 6 wire system for a meter change in the existing installations.

**Table 4.5: Maximum route length of Current Circuit Wiring (m)**

* Maximum demand up to & including 400A	* Maximum demands in excess of 400A	Conductor csa mm <sup>2</sup>
10	20	2.5
16	32	4
25	55	6
40	90	10

\*The maximum demand must be determined in accordance with AS/NZS 3000 unless otherwise advised by the electricity distributor. Consult the electricity distributor if the route length is likely to exceed these values.

### 4.19.3 Voltage Circuit Wiring

The customer must provide the following facilities:

#### 4.19.3.1 Primary Conductor to Fuse

Install a single core insulated and sheathed 4mm<sup>2</sup> cable between each primary conductor and the voltage circuit fuses.

Sheathing may be achieved by using single core insulated cable enclosed in 6mm diameter clear PVC tubing with a wall thickness of 1.5mm.

Make the connection to the primary conductor on the line side and as close as practicable to each current transformer. Refer to Figures 4.18 and 4.20.

The cables must be:

- (a) No longer than 500mm as specified in AS 3439.1 'Low-voltage switchgear and control gear assemblies - Part 1 Type-tested and partially type tested assemblies'.
- (b) Connected to the voltage circuit fuses.
- (c) Protected against mechanical damage.
- (d) Rigidly supported.

### 4.19.3.2 Fuse to Meter

Install four voltage circuit conductors, identified as per Table 4.4, from the voltage circuit fuses and the neutral link to the meter panel.

#### 4.19.3.3 Neutral Cable

The customer must provide a connection facility for the metering neutral conductor. It must be in a readily accessible location close to the CT position.

The connection facility may be:

- (a) A suitable tunnel terminal, or
- (b) A set screw in a neutral bar. The neutral bar may be the neutral conductor for the whole installation or for the portion of the installation being metered.

Alternatively, the connection facility may be in the form of a suitable neutral link installed on the same panel as the voltage circuit fuses. It must be connected by means of 2.5mm<sup>2</sup> cable to an approved neutral conductor as follows:

- (c) Connect the neutral cable to a busbar using a suitable lug.
- (d) Secure the lug with a 6mm diameter set screw into a tapped hole.
- (e) Make the connection clearly visible from the position of the current transformers.

#### 4.19.3.4 Sealing

Provide separate sealing facilities for these connections if they are not contained within a sealed portion of the switchboard.

### 4.19.4 Meter Test Block

The customer must provide and install a meter test block at the meter panel.

The test block must:

- (a) Be front connected with a current, rating of 20A and a voltage rating of 660V.
- (b) Comply with AS/NZS 3000.
- (c) Be capable of accepting two external slide links and have the facility to short each current circuit.
- (d) Be fitted with a slide link and two insulated nuts for each voltage circuit.
- (e) Have a solid bar without slide link for the neutral circuit.
- (f) Have a sealable insulated cover that when in position no conductor or any mounting screw is exposed.

Make the connection of the current circuit and voltage circuit wiring as required by the metering provider. Refer to Figure 4.19 for an example of a meter test block.

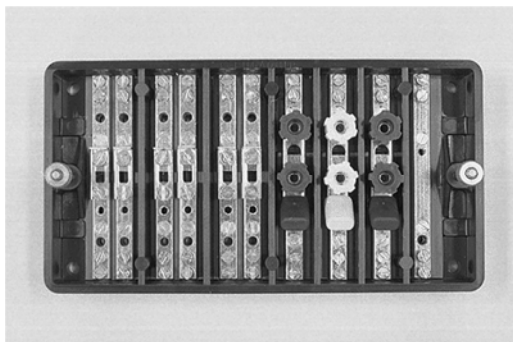
**Figure 4.19: Example of a Meter Test Block**

#### 4.19.5 Summation Equipment Wiring

Refer to the metering provider for details of their summation metering requirements.

#### 4.19.6 Load Control Device and Contactor Wiring

If you provide a contactor in accordance with clause 4.20 you must install a pair of 2.5mm<sup>2</sup> cables between the CT metering panel and the contactor as follows:

- (a) The contactor must comply with the requirements of clause 4.11.3.
- (b) It must be controlled and protected by a suitably rated 10A circuit breaker, both of which have provision for sealing.
- (c) The pair of cables for the contactor may be grouped with other metering cables provided they are visually distinguishable from them.

#### 4.19.7 Earthing of Meter Surround

The customer must connect an earthing conductor to the metal surround of the meter panel in accordance with the provisions of AS/NZS 3000.

#### 4.19.8 Supply for National Electricity Rule Compliant Communications Equipment

Where code compliant CT metering is installed, unmetered supply may be taken for rule compliant data and communications equipment only. This equipment must be connected to a sealable link on the load side of the meter test block (between the test block and the metering).

Where rule compliant whole current metering is installed, metered supply must be taken for rule compliant data and communications equipment. This equipment must be connected to a metered link on the line side of the main switch.

Communications which requires mains supply equipment must be protected by a sealable current limiting (HRC) fuse or circuit breaker with a maximum rated current of 4A (to grade with the 10A current limiting (HRC) meter potential fuse, where CT metering is installed). This equipment does not need to be controlled by a separate main switch and must be hard wired to the supply (socket outlets are not permitted).

Alternatively communications equipment integrated in the meter may obtain a protected supply internally from the meter.

### 4.20 Controlled Load for CT Metering

The customer must supply and install a contactor if electricity is to be supplied (in accordance with the provisions of a tariff) to a CT metered portion of an installation only during certain hours.

Arrange the contactor so that it is operated by the electricity distributor's nominated load control device. The contactor must be of a type approved by the electricity distributor and have:

- (a) The terminals and mechanism enclosed in a manner which facilitates sealing.
- (b) A 240 volt operating coil and be designed to close and open simultaneously with the load control device.

Install the contactor at the meter position or, alternatively, adjacent to the controlled load current transformers. A typical wiring diagram of a CT metering installation with a controlled load contactor is shown in Figure 4.20.



Figure 4.20: CT Metering Circuit with Controlled Load

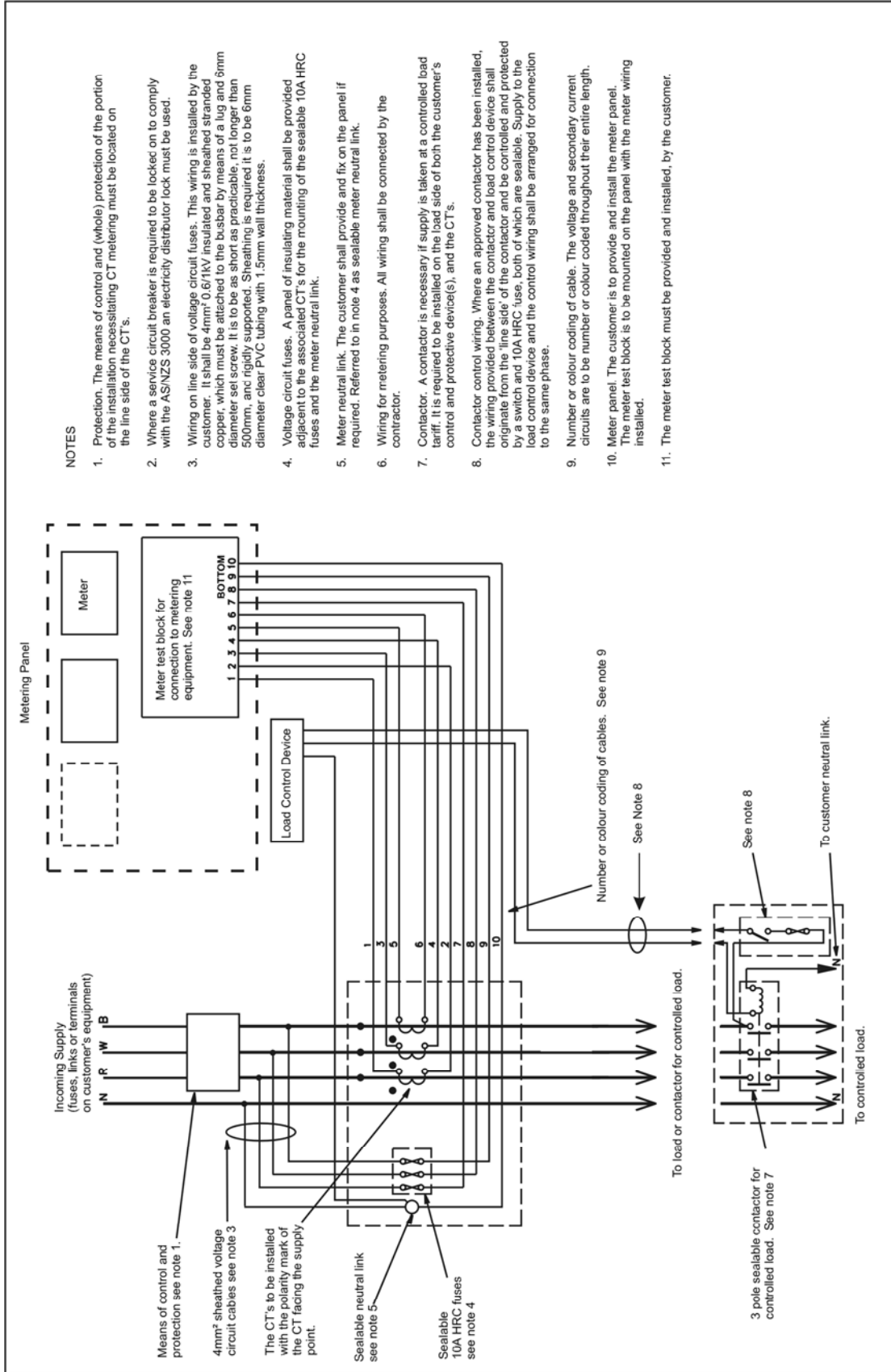

## 4.21 Labelling

Install warning labels on a customer's main switchboard in accordance with the following requirements:

- (a) All warning labels on the main switchboard must have WHITE lettering, minimum 6 mm high, permanently engraved on a RED background.
- (b) Labels for all main switches must be readily distinguishable from all other labels, in accordance with AS/NZS 3000. Different colours may be used for identification so they can be operated quickly in an emergency.
- (c) Provide a schedule for each distribution section within a main switchboard to identify outgoing submains and final sub circuits.
- (d) Equip each combination fuse-switch (CFS) unit with a label stating the maximum current rating of replacement fuses to be installed. Make sure the ratings for the fuses match:
  - i) The current rating of the outgoing submains, and/or
  - ii) The fault current limiting requirements for downstream equipment  
whichever is less.
- (e) Provide each main switchboard with a permanently engraved label with the following information:
  - i) Fault rating for 1 second.
  - ii) The Manufacturer's name or trademark.
  - iii) Type, designation or identification number or other means of identification so that anyone can get relevant information about it from the manufacturer.
  - iv) IP rating.

### 4.21.1 Guide to Labelling Electrical Equipment on Switchboards

This clause cannot cover all the labelling requirements in every situation. To establish consistency and improve safety, the NSW electricity distributors are providing preferred and acceptable examples in known problem situations.

No reference is made to specific clauses in AS/NZS 3000 as electricity distributors do not intend to indicate precise labelling acceptance criteria.

This clause does not remove responsibility from the customer or their representative in complying with:

- (a) Other Australian Standards.
- (b) Requirements of other relevant Regulatory Authorities.
- (c) Other publications if applicable to the situation.

Note: Inadequate labelling, or lack of labelling of equipment at the time of inspection may prevent the connection of electricity.

Avoid temporary labelling - it should not be necessary.

Labelling of equipment needs to be standardised to an acceptable degree so that:

- (a) Authorised persons operating switchgear know which section of the installation the equipment controls.
- (b) Authorised persons working on an installation can do so safely.
- (c) Electrical contractors, equipment suppliers and switchboard manufacturers know what labelling is acceptable.

Wording on labels should be concise, easy to understand, and contain sufficient information to convey the message effectively without ambiguity.

If you use words like "essential", "emergency", "normal" etc, make sure they cannot be confused with words on labels for equipment associated with lifts and fire services.

For example:

- (a) "Essential lighting" would be confused with emergency evacuation lighting (see AS 2293 'Emergency evacuation lighting for buildings').
- (b) Some air conditioning equipment may be essential for a manufacturing process, but the labelling of equipment as "Essential air conditioning" would cause confusion with fire and smoke control equipment.

One example of an acceptable label would be:

#### Label 1

Air Conditioning Motor Control Cubicle. Basement Do No Turn Off Without Consulting Supervisor
--

## 4.21.2 Examples and Explanations of Labelling

### 4.21.2.1 Fault Current Limiters

Examples of acceptable labels are labels 2 to 5.

#### Label 2

Fault Current Limiters for  
.....Circuits  
Mounted Behind This Cover

#### Label 3

WARNING:  
Do Not Re-energise Fault Current Limiters  
Until Fault Has Been Cleared  
Replace With Identically Rated  
Fault Current Limiters

#### Label 4

WARNING:  
These Fault Current Limiters Are Not Controlled  
By a Switch

#### Label 5

WARNING:  
Use Insulated Handle to Remove and  
Replace These Fault Current Limiters

### 4.21.2.2 Main Switches

For labelling main switches use a different background colour to the background colour used for labels of other equipment.

Use white lettering on a red background for warning labels. Also use white on red for labelling main switches for lifts and fire services and associated equipment. (See AS 1319 'Safety signs for the occupational environment').

For switchboards rated at 100A or less, the colour of labels for main switches can be the same as the labels for other equipment.

Abbreviations such as DB 7, FIB, EWIS, and MCC2 are unacceptable.

Examples of acceptable labels are:

- (a) Main Switch - Tenant's light and power, Levels 7, 8 and 9
- (b) Main Switch - House Services light and power, Levels 1-15
- (c) Main Switch - Motor control panel No. 2, Level 12
- (d) Main Switch - Distribution board, Level 3
- (e) Main Switch - Air conditioning board, Level 14.

### 4.21.2.3 Switches for Fire and Smoke Control Equipment

Examples of acceptable labels are:

- (a) Main Switch - Fire hydrant pump. Level 20.
- (b) Main Switch - Fire sprinkler pump. Level 2.

- (c) Main Switch - Fire hose reel pump. Level 7 to 10.
- (d) Main Switch - Fire Indicator Board.
- (e) Main Switch - Emergency warning intercommunication system.
- (f) Main Switch - Smoke control fans switchboard, Level 9.
- (g) Main Switch - Lift 1, High rise, Level 19.

### 4.21.2.4 Installations in Separate Buildings

An acceptable label is shown as label 6 below.

Use internal building numbers wherever possible. Avoid names of companies.

#### Label 6

Main Switch (Location)  
Light, Power, Air Conditioning,  
Lifts and Fire Services

### 4.21.2.5 Main Switchboard Enclosures

Refers to labels 7 and 8 below.

If necessary, the label should also include some means of identifying the premises, eg 7-19 Phillip Street.

#### Label 7

Main Switchboard Electrical Services

#### Label 8

Main Electrical Switchroom

Place signs in large and complex installations at the Fire Indicator Board and at, or adjacent to, the tenant's directory board.

An example of a sign would be label 9 as shown below.

#### Label 9

Main Electrical Switchboards  
Located On Levels B2, 10 & 27.  
Private Generation Switchboard on Level 28

### 4.21.2.6 Switchboard Equipment

Abbreviated labels such as DB 7 or MCC2 are not acceptable. Labels should indicate the floor or level number or location and, if necessary, the type of load, eg:

- (a) Light and power, Level 17, North side.
- (b) Air conditioning board, Level 2.

The use of suitable diagrams mounted on or near the switchboard would be acceptable in complex installations where direct labelling would be excessive and confusing. Make a reference on the switchboard to any diagrams.

**4.21.2.7 Segregation of Supplies**

Labels 10-15 shown below are acceptable examples.

**Label 10**

Main switchboard No. 1  
Electricity Distributor Supply No. 1  
Circuits 1-18 Main Switchboard No. 2  
is Located .....

**Label 11**

Main Switchboard No. 1  
Electricity Distributor Supply No. 1  
Supplies Areas as Shown In Diagram  
Main Switchboard No. 2  
is Located.....

**Label 12**

Main Switchboard No. 1  
Electricity Distributor Supply No. 1  
Supplied From Substation No. 12345  
Main Switchboard No. 2  
is Located .....

**Label 13**

Distribution Board Level 7  
Supplied From No. 1 Main Switchboard

**Label 14**

Electricity Distributor Supply No. 1  
Supplies Main Switchboard No. 1  
Located on Ground Floor

**Label 15**

Electricity Distributor Supply No. 1  
Supplies Main Switchboard No. 1  
Located on Ground Floor  
Private Generation Supply Also Available,  
Isolate at Generator Switchboard on Level 7

**4.21.2.8 Alternative Supplies**

Display a notice prominently on the main switchboard, distribution board or change-over equipment cubicle in accordance with Section 8.

The circumstances to consider are:

- (a) Isolation of the alternative supply to the main switchboard, distribution board or change-over equipment cubicle.
- (b) Isolation of an outgoing circuit from the normal supply switchboard.
- (c) Isolation of a switchboard remote from the switchboard containing the change-over equipment.

Examples of acceptable labels would be:

**Label 16**

WARNING  
Private Generating Plant Will  
Automatically be Connected To  
This Switchboard on Loss Of  
Electricity Distributor Supply.  
Isolate Private Generating Plant  
in Lower Basement

**Label 17**

Main Switch  
Tenant's Light And Power, Levels 1-11  
WARNING  
Alternate Supply Available  
Isolate Also at Circuit Breaker No. 2  
on Private Generating Plant,  
Switchboard on Level 17

**Label 18**

Main Switch  
Controls Circuits 4, 5, 6 & 7  
WARNING  
Alternate Supply Available To Circuit 8.  
Isolate Also at Circuit Breaker No. 3  
on Private Generating Plant  
Switchboard on Level 17

**4.21.2.9 Miscellaneous**

Isolators, automatic transfer switches, mode selector switches and similar unusual equipment, are usually installed so that they are not readily accessible.

Labelling of this equipment on the outside of the switchboard would not normally be necessary.

If labelling is required, it must not cause confusion. Labelling of this equipment on the inside of the switchboard is necessary to explain the purpose of the equipment.

If an automatic transfer switch is to be used as a main switch, then the associated supervisory control switch will need to be accessible. Label it to indicate that it is a main switch and it will isolate both the electricity distributors and the private generation supplies.

Label voltmeter and ammeter selection switches as voltmeter and ammeter selection switches.

**4.21.2.10 Circuit Breakers - Cascade**

Where cascade or series connected circuit breakers are installed for current limiting purposes, the following warning label must be installed adjacent to the circuit breakers.

At upstream circuit breakers.

**Label 19**

WARNING  
All protective devices on this switchboard have been selected to cascade with the downstream circuit breakers. Replace only after consulting manufacturer.

At downstream circuit breakers.

**Label 20**

WARNING  
All protective devices on this switchboard have been selected to cascade with the upstream circuit breakers. Replace only after consulting manufacturer.

## 5 SPECIAL SMALL SERVICES

### 5.1 Introduction

Special arrangements apply for supply to certain small installations usually located in public places. The electricity distributor will provide guidance on the selection of the PCC.

Generally, supply to these small installations does not exceed 230V single phase. Typical small installations include bus stop shelters, public conveniences, floodlights, decorative lighting, direction and locality signs and public telephones, etc. Special Small Services are restricted to public facilities located in public places.

Generally, meters are not used in these installations because an accurate assessment can be made of the energy usage.

Supply from the distribution mains allows for 24 hour operation and is not restricted. A time control switch or other controller may be required where the customer wishes to restrict the time of operation.

The electrical installation may only be connected to controlled street lighting mains if all of the following apply:

- (a) There are no distribution mains available.
- (b) Operation of the installation is only required at night.
- (c) There is adequate capacity in the street light mains to supply the proposed load (consult with the electricity distributor).
- (d) An individual controller is installed within the electrical installation, to restrict operation to night time usage, eg photoelectric cell.

Submit a location sketch of each site to the electricity distributor's local office. It should detail the position of the customer's structure with distances from the electricity distributor's equipment and property lines.

These arrangements do not include supplies to building sites or fetes etc, in public places.

### 5.2 Connection to the Distribution System

#### 5.2.1 Underground Supply from Overhead Mains

Figure 5.1 shows the standard arrangements for an underground electricity supply from overhead mains. The customer must supply and install an approved connection point termination box on the electricity distributor's distribution pole. The box and conduit are to be mounted on the pole face opposite the traffic flow.

The customer must provide and arrange for the installation of the service consisting of minimum 6mm<sup>2</sup> stranded copper conductors single core thermoplastic insulated and sheathed cable.

An accredited service provider, authorised by the electricity distributor will install and connect the service cable to the electricity distributor's overhead distribution mains.

The service must be installed as follows:

- (a) Enclose the cable on the pole in flexible plain conduit to AS 2053.4. 'Conduits and fittings for electrical installations Part 4: - Flexible plain conduits and fittings of insulating material'.
- (b) Provide enough conduit to reach the cross arm and enable a weather loop to be formed adjacent to the PCC.
- (c) Provide 1500mm of cable free of conduit at the PCC to enable the connection to the distribution mains.

(d) Attach the conduit to the pole above the terminal box using sufficient full (2 hole) galvanised saddles and 40mm long galvanised clouts. Refer to clause 5.4 where other than timber poles are used.

(e) Maximum number of UG/OHs on the electricity distributor's pole must comply with clause 2.10.4 of these rules.

#### 5.2.2 Underground Supply from Underground Mains

Figure 5.2 shows the standard arrangements for supply from the electricity distributor's underground distribution mains. The customer must supply and install a connection point termination box within an underground pit, pillar or structure, near the PCC. The route length of service cable must not exceed 10m.

Figure 5.3 shows the standard arrangement where supply is taken from the electricity distributor's street lighting standard or pillar.

Do not mount any customer equipment within the electricity distributor's equipment unless the electricity distributor gives permission.

An accredited service provider authorised by the distributor, will connect the underground service cable to the distributor's underground distribution mains. The customer will supply the cable between the distributor's underground mains and the connection point termination box.

The customer must provide and arrange for the installation of the underground service cable consisting of minimum 6mm<sup>2</sup> stranded copper conductor single core thermoplastic insulated and sheathed cable.

The cable must be installed in accordance with the AS/NZS 3000 and the principles outlined in this Section. Enough cable is to be provided to connect the underground service cable to the underground distribution mains.

Underground cabling must be installed in heavy duty UPVC conduit as specified in AS/NZS 3000 for Category A system enclosure, or as approved by the electricity distributor. The underground conduit must maintain 500mm depth throughout its length.

Orange marker tape, complying with AS 2648.1 'Underground marking tape Part 1: - Non-detectable tape' must be installed 300mm above all underground electrical conduits.

Underground electrical conduits located in footpaths are to run parallel with or at right-angles to the property line in accordance with Figure 5.2. Refer to Section 2 - Underground Services.

### 5.2.3 Overhead Service to Customer's Structure

Where an overhead service is installed to a POA on a customer's structure, refer to Section 3 - Overhead Services.

## 5.3 Customer's Structure

For structures to be erected over the electricity distributor's footpath allocation for underground mains, the electricity distributor must be consulted to obtain their conduit requirements.

Figure 5.6 gives general requirements on the provision and installation of conduits in accordance with this clause.

## 5.4 Concrete and Steel Poles

Where concrete and steel poles are used you must provide stainless steel "band-it" or similar bands. The bands must have suitably sized conduit saddles to fix the conduit to the pole.

Equipment mounted on the pole must also use bands to fix it in place. **Do not drill any holes in concrete or steel poles for fixings.**

## 5.5 Electrical Installation

### 5.5.1 Type of Installation

The installation and wiring must comply with AS/NZS 3000 and this Section and may be either a double insulated or earthed installation.

If it is double insulation, all fittings and accessories must comply with the requirements of double insulation.

Where earthing is required it must be arranged as a multiple earthed neutral (MEN) system, unless the installation is on railway land, refer to clause 1.16.7.1.

A notice in accordance with the requirements of the Electricity (Consumer Safety) Regulation 2006 is to be submitted for all work associated with the electrical installation.

### 5.5.2 Connection Point Termination Box

Alternative box mounting positions to clauses 5.2.1 and 5.2.2 may be:

- On a customer pole, wall or structure, or
- Within a customer's pillar; or
- Near the POA of an overhead service.

The terminal box must meet the following requirements:

- (a) If the box is in a pillar or structure it must be 150mm minimum above ground level.
- (b) The box, complete with lid and sealing gasket must be of suitable size to permit the necessary connections.
- (c) The box must have a minimum rating of IP23, for above ground use and IP27, for below ground use.
- (d) Access to a box not installed above 3000mm, or a box in a pit, must require use of a tool and the box must be suitable to minimise vandal damage.

### 5.5.3 Control and Protection

The electrical installation must be provided with a **main control** and **overcurrent protection**. To satisfy this, the box must contain either:

- (a) A double pole switch for double insulated installations, or
- (b) A single pole switch, or
- (c) Combined Residual Current Device and Circuit Breaker (RCD/MCB).

A 20A minimum, current limiting (HRC) fuse carrier and base and neutral link must be installed in all options. The current limiting (HRC) fuse link must be a maximum of 20A. The current limiting (HRC) fuse may be both the service protection fuse and circuit protection.

Exceptions to this requirement are:

- i) Installations where the customer wishes to supply load by means of an installed plug socket only. The plug socket control may be a switch which may be considered the installation main switch.
- ii) A switch installed at the PCC may be considered as the installation main switch.
- iii) Where supply is taken from a street lighting standard or a pillar, the current limiting (HRC) fuse at the PCC is the circuit protection for the installation and the box need only contain the main switch or RCD/MCB.

In all other cases AS/NZS 3000 will apply.

Figure 5.4 shows a connection point termination box for 230V power supply suitable to be mounted on a pole, wall or structure or within a pillar. The connection point is at the line side of the fuse mounted in the box, where the latter is mounted on an electricity distributor's distribution pole.

Figure 5.5 shows a connection point termination box for 230V power supply installed below ground.

#### 5.5.4 Installation on the Electricity Distributor's Pole

Refer to Figure 5.1. The method of installation on the electricity distributor's pole must meet the following requirements:

- (a) The submains or final subcircuit installed between the connection point termination box and the customer's structure must be installed in flexible plain conduit to AS 2053.4 'Conduits and fittings for electrical installations Part 4: - Flexible plain conduits and fittings of insulating material' from the terminal box to a minimum of 1000mm from the base of the pole and be suitably protected against mechanical damage.
- (b) The conduit must be protected to comply with clause 2.10.2 of these rules.

- (c) The connection point termination box is to be maintained by the customer and installed on the pole face opposite the traffic flow, a minimum of 3,000mm and a maximum of 3,800mm above ground.
- (d) Using sufficient full (2 hole) galvanised saddles and 40mm long galvanised clouts to secure the conduit to the timber pole (refer to clause 5.4 where other than timber poles are used). The conduit must be installed on the pole face opposite the direction of traffic flow.
- (e) The customer will install the submains/final subcircuit up to the connection point termination box.
- (f) The required mechanical protection of submains or final subcircuits between 2500mm above ground line and 300mm below ground line must be tubular or 'U' section construction with no side flanges (side securing tabs are permitted) to minimise the surface area of the pole that is covered.

**Unless authorised, the accredited service provider is not permitted to work on or near the electricity distributor's mains.**

#### 5.5.5 Earthing

The earth electrode may be located:

- (a) Adjacent to the electricity distributor's pole, in a customer's pit (containing the connection point termination box or a separate pit), or
- (b) Within or adjacent to the structure being supplied. If within the structure the connection must be accessible from an inspection cover.

For electrical installations on railway land, special conditions may apply.

#### 5.5.6 Labelling

Where the connection point termination box is not readily associated with the equipment it controls, the box and the equipment must be labelled to indicate their respective locations.

#### 5.5.7 Underground Sub Mains

The electrical installation wiring should be installed where possible in the electricity distributor's footway allocation.

Figure 5.1: Standard arrangements for 230V power supply from overhead mains

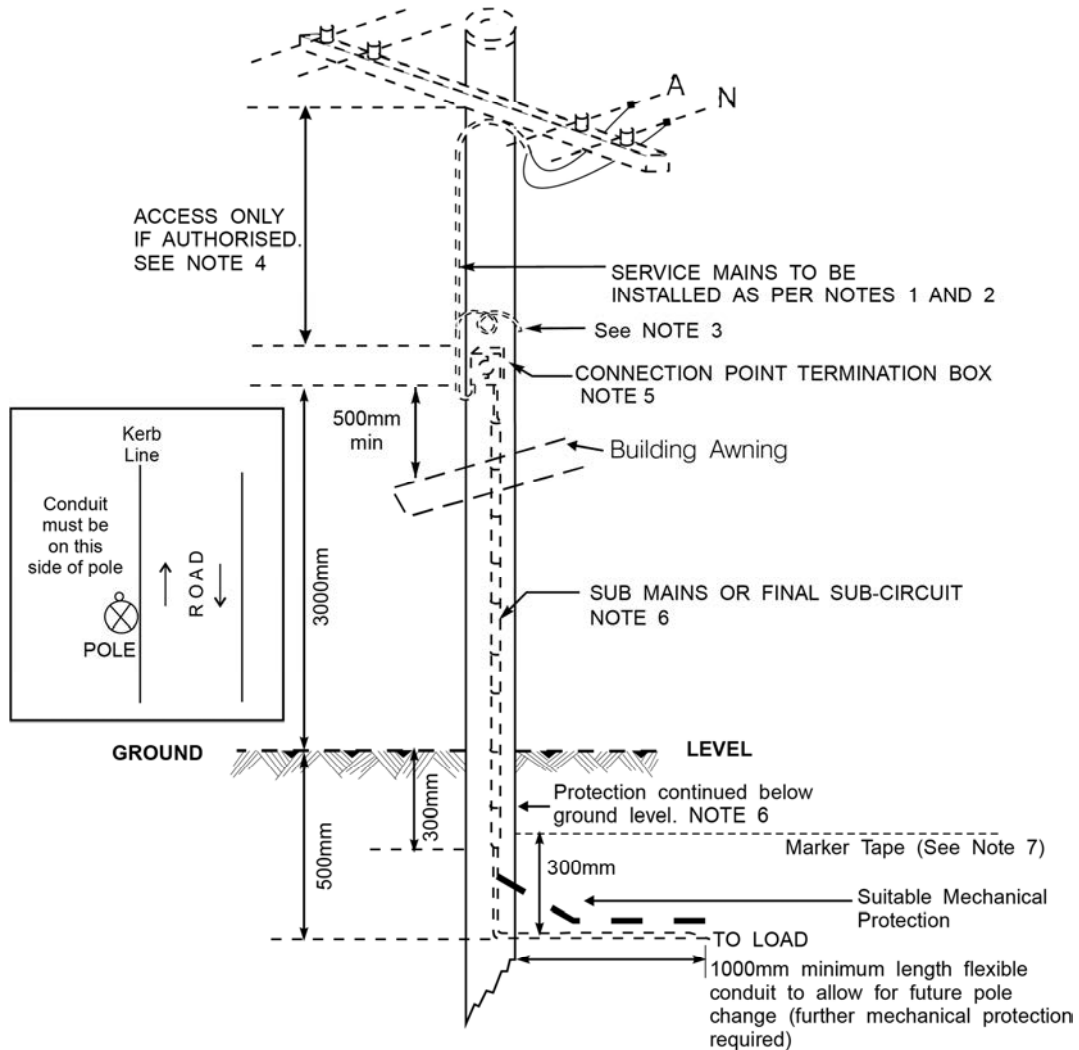

## Note:

1. Install the required length of minimum 20mm flexible plain conduit (conduit to comply with AS 2053 'Part 4 flexible plain conduits and fittings') with minimum 6mm<sup>2</sup> single core double insulated cables for installation between the connection point termination box and the Point of Common Coupling. Fix and terminate at the connection point termination box.
2. Allow 1500mm of free length of cable without conduit at the electricity distributor's crossarm to connect to the electricity distributor's mains.
3. If not authorised, coil the cable and securely attach to the pole at the connection point termination box for the accredited service provider's authorised person to complete the work. Also leave sufficient double hole galvanised saddles and 40mm long clouts for fixing the conduit. (Allow for spacing of saddles to be 400mm maximum).
4. Only authorised Accredited Service Providers are permitted to work on or near the electricity distributor's distribution system.
5. The customer is to provide and maintain an approved connection point termination box. Refer to Figure 5.4. The box may also be located nearby on a wall or structure where supplied by an overhead service main.
6. Cables to be installed in conduit between the connection point termination box and the customers structure. The conduit on the pole and within 1000mm of the base of the pole must be flexible plain conduit, to AS 2053 - Part 4, or as agreed with the electricity distributor. The conduit is to be suitably protected against mechanical damage:
  - up to a distance of 2500mm above the finished ground level, and
  - over the underground portion of the flexible plain conduit.
7. Install marker tape 300mm above the conduit (refer to clause 5.2.2)



**Figure 5.2: Typical arrangements for 230V power supply from underground mains**

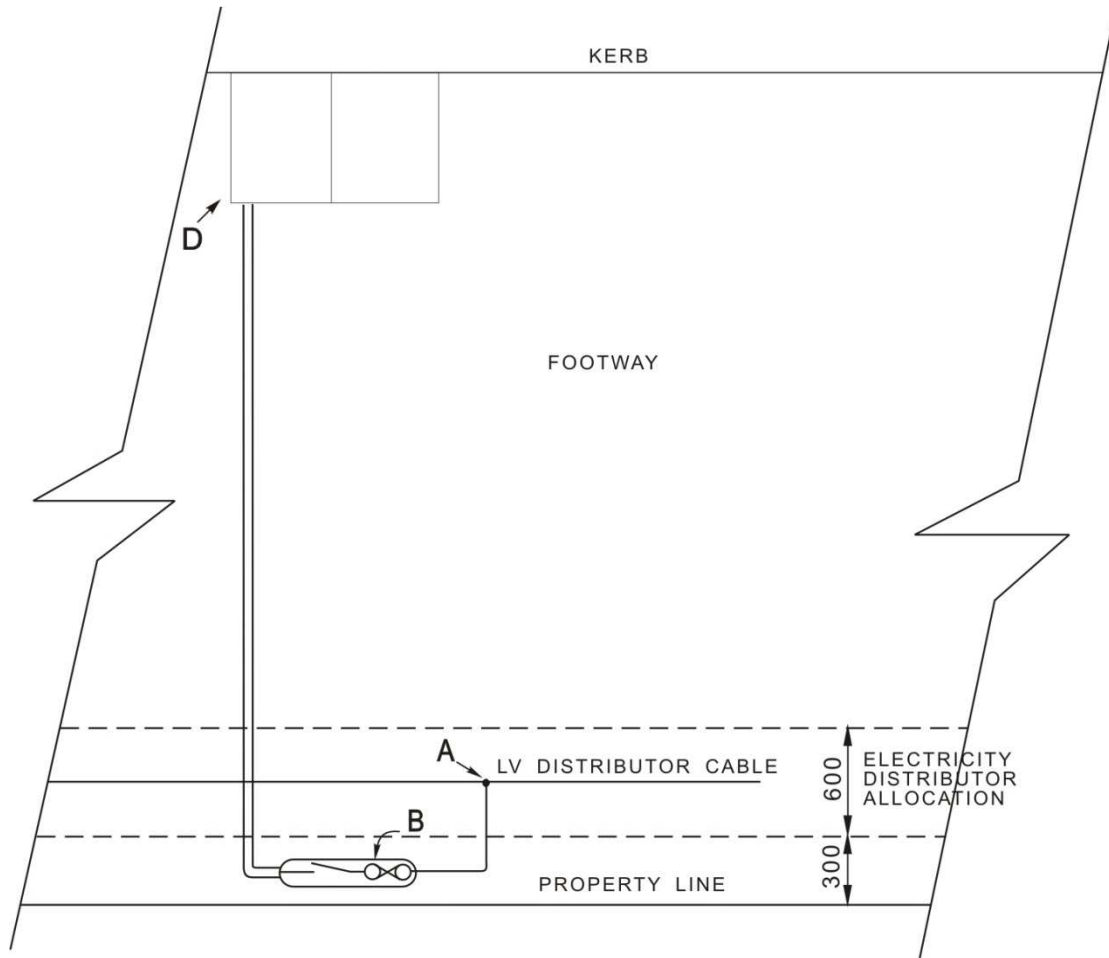

- A Refer to the electricity distributor for supply details, connection to the mains may be via a tee joint, distribution pillar or street light column.
- A-B Minimum 6mm<sup>2</sup> copper 0.6/1kV single core PVC/XLPE or PVC/PVC cable installed in accordance with the AS/NZS 3000 and clause 5.2.2 (to be kept as short as possible, maximum length is 10 metres).
- B Approved pit service box supplied and installed by the customer. Refer to Figure 5.5 - connection point termination box installed in a pit below ground or Figure 5.3 when installed in a pillar or structure.
- B-D Cable installed by customer in accordance with the AS/NZS 3000 and clause 5.2.2.
- D Electrical installation.

Note: Where the customer's footway structure is built over the electricity distributor's footway allocation, ducts are to be laid beneath the structure in accordance with Figure 5.6.

**Figure 5.3: Typical arrangements for underground 230V power supply from a steel street lighting standard**

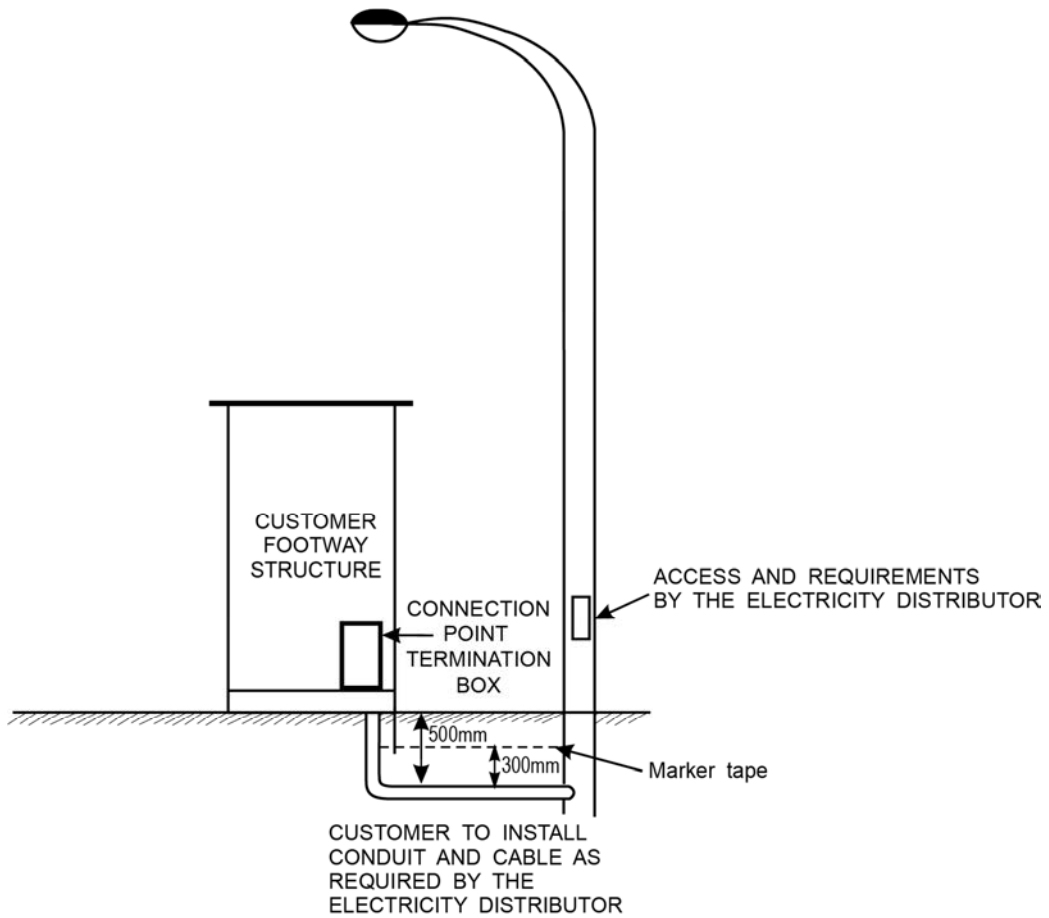

- Note:
1. Refer to Figure 5.2 for requirements of laying customer's cables in footway.
  2. Refer to Figure 5.6 for requirements of ducts under customer's footway structure.
  3. Install marker tape (refer to clause 5.2.2)

**Figure 5.4: Typical Connection Point termination box 230V power supply for above ground use (pole mounting illustrated)**

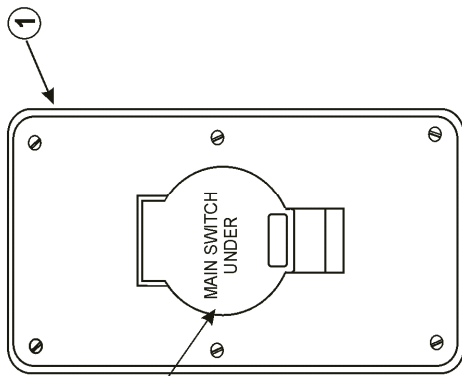
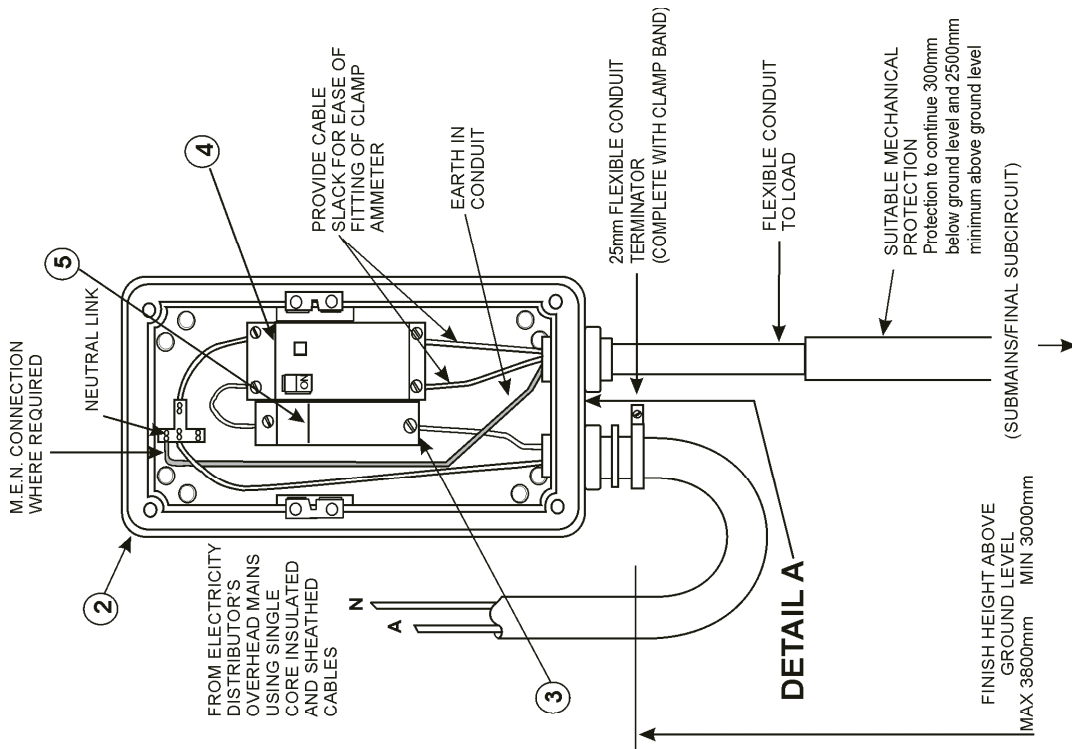

SOLID COLOUR UV STABILISED FLAP COVER AND SEAL

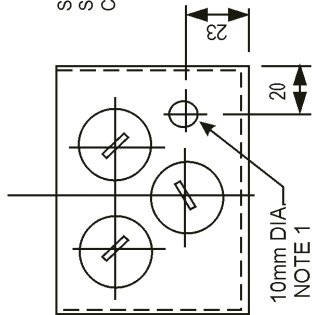

**DETAIL A (N.T.S.)**  
LOCATION OF 10mm D/A. HOLE TO PREVENT CONDENSATION

ITEM NO	DESCRIPTION	NO. OFF
5	CURRENT LIMITING (HRC) FUSE	1
4	COMBINED RCD/MCB 16A 30mA CORE BALANCED EARTH LEAKAGE CIRCUIT BREAKER OR SWITCH	1
3	FUSE HOLDER CURRENT LIMITING (HRC) SERVICE FUSE FRONT ACCESS THROUGH FLAP OR BY REMOVAL OF COVER	1
2	ENCLOSURE UV STABILISED	1
1	COVER ASSEMBLY GREY UV STABILISED COMPLETE WITH SEALING GASKET	1
	DESCRIPTION	NO. OFF

**NOTE 1.** Remove plug at installation or drill 10mm hole to prevent condensation

**Figure 5.5: Connection Point termination box for 230V power supply installed in a pit below ground**

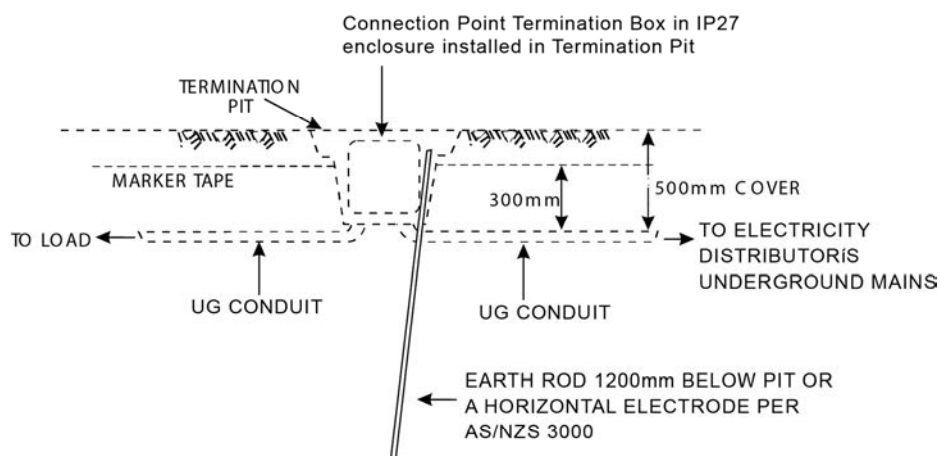

**GENERAL ARRANGEMENT**

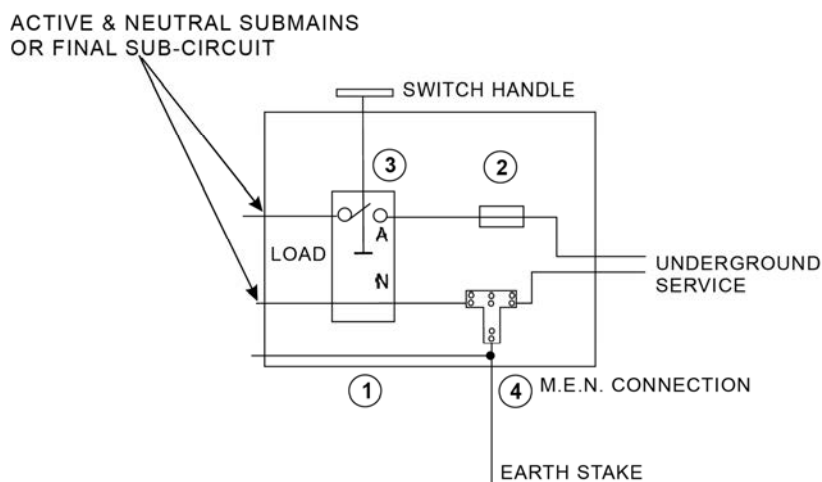

**CONSUMERS TERMINAL BOX**

**Components**

- ① Enclosure to be IP27 rated.
- ② Current limiting (HRC) fuse carrier and base 20A minimum, maximum 20A current limiting (HRC) fuse link.
- ③ Combined RCD/CB may be used in place of a switch.
- ④ Neutral link and earth connection

**Figure 5.6: Typical installation of ducts under customer's footway structure**

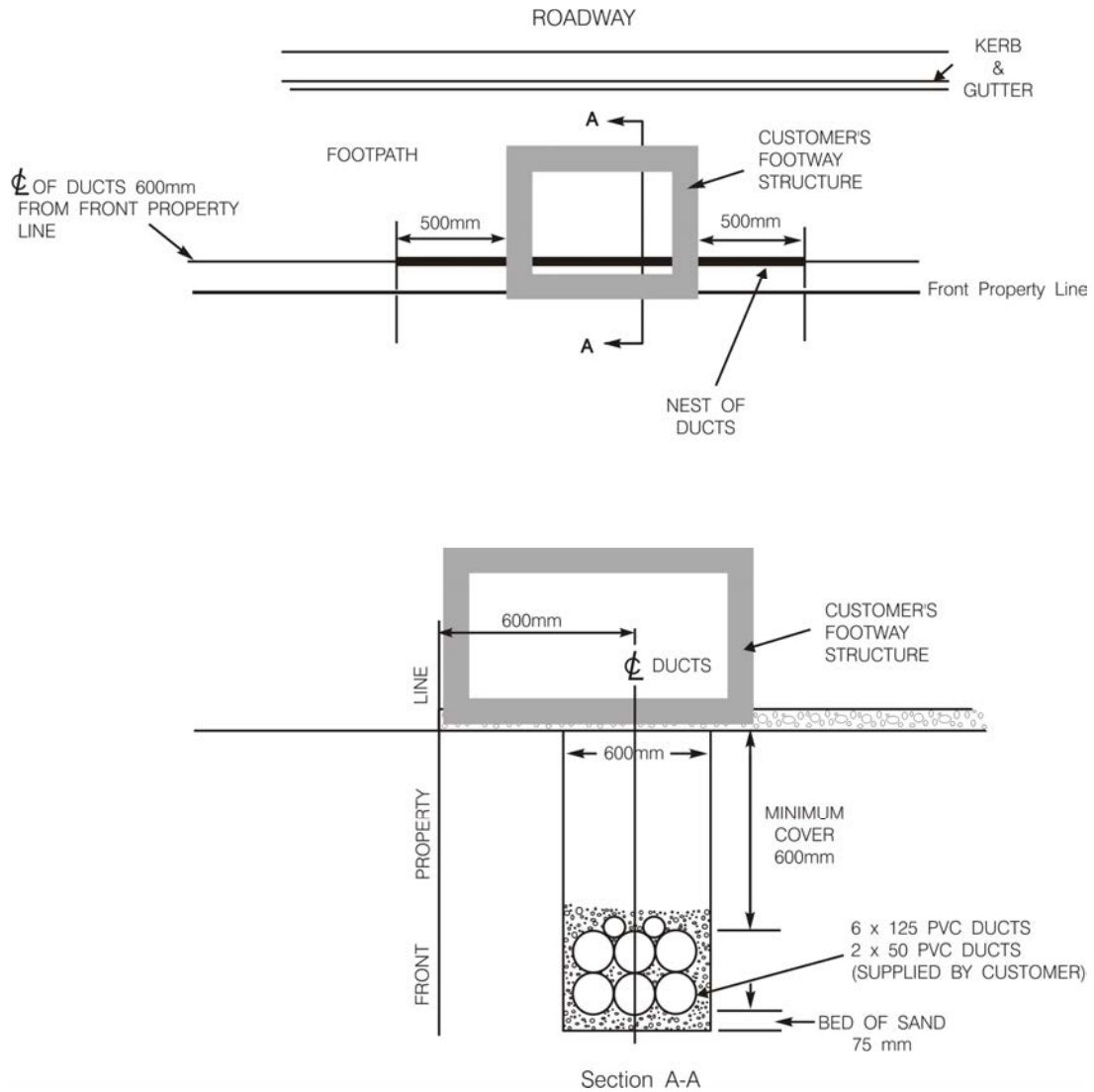

- Note:
1. Confirm the electricity distributor's requirement and cable location prior to carrying out any excavation.
  2. Ducts to be installed on 75mm bed of sand.
  3. Ducts to be installed in a straight line and at an even grade.
  4. End of ducts to have each end plugged with PVC plugs prior to backfilling.
  5. Minimum of three working days notice to be given for work on site.

# 6 CAPACITOR INSTALLATIONS

## 6.1 Introduction

Industrial and commercial loads require significant amounts of reactive power (kVAr) for the operation of motors, furnaces, electric discharge lighting and the like. The result is a low power factor. The low power factor can be improved by applying capacitors to supply this reactive power.

### 6.1.1 Minimum Power Factor

Clause 1.16.11 requires an electrical installation to have a power factor of 0.9 or greater lagging.

#### CAUTION

The power factor of the installation must not become leading at any time

### 6.1.2 What is Power Factor

**Power Factor** is all about the effective use of the electricity distributor's distribution system. It is a measure of how effectively you turn the electricity supplied to your business into actual productive power (i.e. light, heat, motive power). By improving your power factor you could reduce your energy costs if it is charged at a tariff incorporating a kVA demand component or a power factor penalty.

The costs of a kVA demand type tariff and a kWh tariff are not the same. There is a difference between the power supplied to your premises **Apparent Power** (measured in kVA) and the power consumed in your electrical equipment **Real Power** (measured in kW).

This difference is due to electromagnetic fields. **Reactive Power** (measured in kVAr) is required to establish electromagnetic fields which allow magnetic coils to operate. These coils are found in fluorescent and mercury vapour lighting, electric motors and many other types of equipment.

### 6.1.3 Expressing Power Factor

Commercial and industrial customers, by the very nature of their activities, require, in addition to real power, a significant proportion of reactive power.

Magnetic fields in motors, induction furnaces, transformers and discharge lighting are maintained by reactive current.

Reactive power is not seen by the kWh energy meters, but its presence causes a demand kVA to be significantly higher than the kW value, as shown below.

This relationship is represented mathematically by the cosine of the angle  $\phi$  between real power and apparent power.

$$\text{Power Factor} = \text{kW/kVA} = \cos \phi$$

Obviously, correction of the power factor to near unity ( $\cos \phi = 1$ ,  $\phi = 0$  degrees), will minimise the kVA demand.

Connecting capacitors to an electrical installation achieves this.

Power Factor Relationship

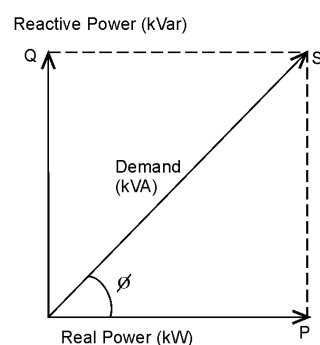

### 6.1.4 Why Power Factor is Important to your Business

Improving your power factor can mean a significant benefit to your business.

It can achieve this in two ways:

- If you pay for electricity using a kVA demand tariff, a higher power factor would reduce your peak kVA demand and save money on your electricity account.
- If the main switchboard or service/consumers mains are loaded to capacity, an improvement in power factor may provide additional capacity at a lower cost than the replacement of the switchboard or upgrading of the service/consumers mains.

### 6.1.5 Power Factor Correction

A higher power factor for the installation can be achieved by reducing the total amount of reactive power required by your electrical installation.

In most cases power factor is best corrected by connecting capacitors at the load terminals, for example, at each motor or each luminaire. However, for economic reasons power factor correction usually takes place at the customer's main switchboard using switchable capacitor banks.

The cost of installing power factor correction capacitors can usually be recovered through reductions in electricity costs.

### 6.1.6 Cost Savings

Significant savings can be achieved by controlling the electrical installation's overall power factor.

As an example, improving a power factor of 0.67 to 0.98 will result in a reduction of about 20% in the total demand charge. You could expect to get your money back on the cost of the associated power factor control equipment in 12 to 18 months.

Even with low levels of power factor correction, the savings can be worthwhile.

The sample calculation below demonstrates a method of estimating the cost benefits of correcting power factor.

In the sample calculation below, the required kVAr of capacitors needed to improve the power factor to 0.9 is calculated at 480 kVAr, and the resultant monthly saving in electricity charges is \$1,650. With an estimated cost of \$30,000 for the capacitors and associated control equipment, the pay-back period would be approximately 18 months.

#### SAMPLE CALCULATION

(Example using a kVA demand charge of \$6.60/kVA/month. Costs applying at the time are to be used.)

Assume that with a load of 1800kW at 0.8 power factor, it is desired to correct the power factor to 0.9. What amount of kVAr correction will be required, what are the expected savings on a Demand Tariff, and what will be the anticipated pay-back period?

Quantity	Present Power Factor 0.8	Required Power Factor of 0.9
Real Power-kW	1800	1800
kVA = kW/power factor	1800/0.8 = 2250	1800/0.9 = 2000
$kVAr = \sqrt{kVA^2 - kW^2}$	$\sqrt{2250^2 - 1800^2} = 1350$	$\sqrt{2000^2 - 1800^2} = 870$
Correction kVAr		1350 - 870 = 480
Demand Charge @\$6.60/kVA/Month	\$14 850	\$13 200
Monthly Savings		\$1 650
Est. Cost of Correction Equipment		\$30,000
Pay-Back Period Months		18

Note: Sample costs are from the 2006 edition of the Rules and may no longer be representative.

## 6.2 Equipment Requirements

Power factor correction equipment may be located:

- (a) In or connected to a distribution board for that part of the installation supplied by that distribution board.
- (b) At the main switchboard for the whole of the installation.
- (c) In individual electric discharge lighting circuits.
- (d) In individual equipment such as induction furnaces, motors, lighting fittings, etc.

The kVAr value of capacitor banks you need to install to correct from an existing to a desired power factor for a particular kW load is set out in Table 6.1. Use this table as a guide when designing an installation.

Shunt capacitors must comply with publications AS 2897 'Power capacitors - Shunt - rated voltages above 660V AC.' or IEC 60831-1 'Shunt power capacitors of the self-healing type for AC systems having a rated voltage up to and including 1000V Part 1: General Performance, testing and rating - Safety requirements - Guide for installation and operation' as appropriate'.

Application for the connection of power factor correction equipment must be made to the electricity distributor. An application is required for each connection except where fitted to individual items of equipment with low power requirements.

Obtain agreement from the electricity distributor before you commit funds or install the power factor correction equipment.

### 6.2.1 Capacitor Switching Steps

In addition to the above requirements the automatic control capacitors must be made in steps to not affect the ripple frequency. However, the electricity distributor may consider larger steps in the following circumstances:

- (a) If the capacitors are switched with equipment as one unit, then there is no limit to the size of capacitors; or

- (b) In exceptional or special circumstances where switching is not frequent, and either:

- i) The installation is connected to a low impedance supply system (an example would be where the installation is in the proximity of, or directly connected to, an appropriate size of substation).
- ii) Other conditions which make sure that the supply to other customers is not affected.

### 6.2.2 Equipment Design

The design of the power factor control system to meet the customers and the electricity distributor's requirements is a complex matter.

Therefore:

- (a) It is recommended you use a competent energy management consultant.
- (b) Discuss the detailed aspects of the design of the power factor correction installation with the electricity distributor before it is manufactured.
- (c) Submit any impedance improvement equipment for approval before connection. Impedance improvement equipment is necessary with power factor correction equipment to reduce the attenuation effect on the electricity distributor's ripple control signal. Refer to clauses 6.6, 6.7 and 6.8.

### 6.2.3 Fluorescent Lighting Installations

In general, leading and lagging ballasts or power factor correction capacitors with series inductors are suitable for fluorescent lighting installations. Leading and lagging ballasts are available as a dual unit within the one fitting.

When leading and lagging ballasts are used in separate fittings, a leading ballast in one lamp for every two lamps satisfies the power factor and blocking requirements of clause 6.4. Table 6.2 illustrates the effect of different fluorescent lighting circuits.



**Table 6.1: Power Factor Correction, Determination of kVArS Required**

Method:

Select the cell where the Original Power Factor row intersects with the Corrected Power Factor column.

Multiply the table values x kW load = Number of kVArS needed to correct from existing to desired power factor.

Original Power Factor	Corrected Power Factor										
	0.80	0.82	0.84	0.86	0.88	0.90	0.92	0.94	0.96	0.98	1
0.50	0.982	1.034	1.086	1.139	1.192	1.248	1.306	1.369	1.440	1.529	1.732
0.52	0.893	0.945	0.997	1.050	1.103	1.159	1.217	1.280	1.351	1.440	1.643
0.54	0.809	0.861	0.913	0.966	1.019	1.075	1.133	1.196	1.267	1.356	1.559
0.56	0.730	0.782	0.834	0.887	0.940	0.996	1.054	1.117	1.188	1.277	1.480
0.58	0.655	0.707	0.759	0.812	0.865	0.921	0.979	1.042	1.113	1.202	1.405
0.60	0.583	0.635	0.687	0.740	0.793	0.849	0.907	0.970	1.041	1.130	1.333
0.62	0.516	0.568	0.620	0.673	0.726	0.782	0.840	0.903	0.974	1.063	1.266
0.64	0.451	0.503	0.555	0.608	0.661	0.717	0.775	0.838	0.909	0.998	1.201
0.66	0.388	0.440	0.492	0.545	0.598	0.654	0.712	0.775	0.846	0.935	1.138
0.68	0.328	0.380	0.432	0.485	0.538	0.594	0.652	0.715	0.786	0.875	1.078
0.70	0.270	0.322	0.374	0.427	0.480	0.536	0.594	0.657	0.728	0.817	1.020
0.72	0.214	0.266	0.318	0.371	0.424	0.480	0.538	0.601	0.672	0.761	0.964
0.74	0.159	0.211	0.263	0.316	0.369	0.425	0.483	0.546	0.617	0.706	0.909
0.76	0.105	0.157	0.209	0.262	0.315	0.371	0.429	0.492	0.563	0.652	0.855
0.78	0.052	0.104	0.156	0.209	0.262	0.318	0.376	0.439	0.510	0.599	0.802
0.80	0.000	0.052	0.104	0.157	0.210	0.266	0.324	0.387	0.458	0.547	0.750
0.82		0.000	0.052	0.105	0.158	0.214	0.272	0.335	0.406	0.495	0.698
0.84			0.000	0.053	0.106	0.162	0.220	0.283	0.354	0.443	0.646
0.86				0.000	0.053	0.109	0.167	0.230	0.301	0.390	0.593
0.88					0.000	0.056	0.114	0.177	0.248	0.337	0.540
0.90						0.000	0.058	0.121	0.192	0.281	0.484
0.92							0.000	0.063	0.134	0.223	0.426
0.94								0.000	0.071	0.160	0.363
0.96									0.000	0.089	0.292
0.98										0.000	0.203

Table 6.2: Lighting Circuits

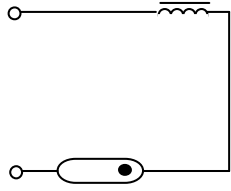
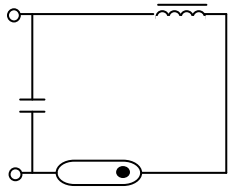
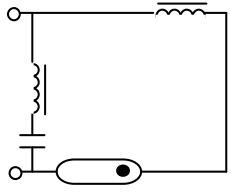
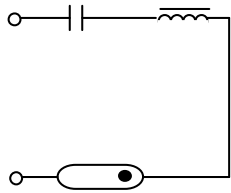
Circuits	Power Factor	Effect on ripple signal (see Note 2)	Compliance with Service Rules
<p>1</p> 	Low power factor approx. 0.4 lagging, known as a "lagging ballast"	No interference to ripple signal	Does not comply due to poor power factor
<p>2</p> 	High power factor. Depends on value of capacitor usually about 0.9 lagging.	The presence of the shunt capacitor appears as a low impedance to the ripple signal, hence reducing the voltage of the ripple signal.	Does not comply without the use of a "stopper" circuit in either the final subcircuit, submains or mains.
<p>3</p> 	High power factor. Depends on value of capacitor usually about 0.85 lagging.	Placing an inductor in series with the capacitor (where the combination is tuned to a frequency below that of the ripple signal) will not interfere with the ripple signal.	Satisfies the requirements
<p>4</p> 	A capacitor in series with the ballast is known as a "leading ballast", approx. 0.4 leading.	No interference to ripple signal	Satisfactory if used in combination with lagging ballasts as shown in Circuit 1.

## Notes:

- Tests have shown satisfactory results using "leading and lagging" ballasts in combination. The ratio of luminaires with leading ballasts to luminaires with lagging ballasts should be 1 to 1, i.e. 1 luminaire with leading ballast to 1 luminaire with lagging ballast. The "leading ballast" most successfully tested was a combination normal 36 watt lagging ballast in series with a 440V 3.1 microfarad capacitor giving a leading power factor of 0.4 for a ripple frequency of 1050 Hz.
- This does not apply to areas which do not use ripple signals.

## 6.3 Existing Installations

Any additional load must comply with the minimum power factor requirements of clause 6.1.1.

The electricity distributor may also require the entire installation to comply with minimum power factor requirements of clause 6.1.1.

### 6.3.1 Power Factor Problems in Non-Domestic Multi-Tenanted and Large Installations

In multi-tenanted installations where power factor is poor for the total installation, any additional load may require upgrading of the supply facilities.

The premises should have its poor power factor corrected if the power factor of the entire installation is less than 0.9 and power factor correction would cater for the increased load required. The customer will avoid the cost of an uneconomic extension to supply, i.e. additional facilities.

This may be achieved by:

- (a) Installing the power factor correction equipment within the metered house services section of the premises electrical installation.
- (b) If this is not possible because the house services load is small when compared to the total site, the electricity distributor may allow the correction equipment to be connected to the line side of the meters of all customers, i.e. at the unmetered main switchboard. This would be unmetered, and its consumption would need to be estimated.

Do not seal the power factor correction equipment as it would be impracticable for maintenance of fuses, contactors and other equipment.

Label the section with unmetered supply to highlight it. The unmetered section should also be labelled with total power losses at 100% utilisation of the power factor correction equipment at rated voltage.

## 6.4 Ripple Control and Harmonic Blocking

Ripple control signals are used as a load control system for the switching of water heaters, street lighting and meter equipment. Where it is agreed that power factor correction capacitors are to be installed and the electricity distributor uses ripple control, the customer must install additional equipment to block the electricity distributor's ripple control signals. The areas where ripple control is used are available from the electricity distributor.

The frequencies used depend on the region within the electricity distributor's area. The frequencies used by each electricity distributor are detailed in Table 6.3.

At audio signal frequencies, capacitors present an impedance of some 10 to 21 times less than at 50Hz. This can result in a significant portion of the signal being absorbed or lost to the system. The effect on the signal voltage of the control system is variable, depending upon the size and number of capacitors and their distribution in the high and low voltage network.

In the worst case the capacitor impedance may approach or equal the inductive reactance of the distribution transformer(s), to form a series resonance combination and a virtual short-circuit on the ripple system. Avoid this undesirable and unacceptable condition by connecting blocking inductors in the capacitor circuit.

Shunt capacitors used for power factor correction are likely to cause significant loss to the ripple control signal. Their impedance to the frequency must be increased by connecting either BLOCKER, REJECTER or STOPPER CIRCUITS to a value which will prevent interference to the electricity distributor's ripple control system.

The designer of the power factor correction equipment should also be aware that harmonics may either be created by the installation itself or exist on the supply network. These harmonics may harm the capacitors, and the capacitors should be protected by suitable harmonic blocking.

Note: Although electricity distributors permit the use of any methods stipulated in the following clauses it should be emphasised that the preferred method is through the use of detuning reactors. (A detuning reactor is a reactor selected to tune the resonant frequency below any likely harmonics).

It is often difficult to attain the required level of impedance using other methods, and it should be noted that the full costs of re-inspection due to failure to meet impedance levels will be borne by the customer.

In addition, the electricity distributor may, in future, require improved shunt impedance due to the need for powerline carriers. In this event, further blocking would be required of customers utilising capacitor banks without detuning reactors.

Customers not providing detuning reactors shall install suitable equipment to prevent switching spikes.

The use of power factor correction without detuning reactors greatly increases the risk of damage from harmonics and the incidence of litigation from other customers due to damage. Although detuning reactors will not nullify these risks, they will be significantly reduced.

Typical single line diagrams representing various arrangements are shown in clauses 6.6, 6.7 and 6.8.

**Table 6.3: Ripple Frequencies by Electricity Distributor (as at 1/06/05)**

Electricity Distributor	Area	Signal Frequency (Hz)
<b>Ausgrid</b>	Upper Hunter	492 & 750
	Hunter Valley	1050 & 750
	Hunter other areas	1050
	Central Coast	1050
	Manly/Warringah Mackellar	1050
	St George	492
	Sydney – other areas	750
<b>Endeavour Energy</b>	Thirroul to Kiama	750
	Kandos Area	396
	<b>Nowra</b>	<b>283</b>
	<b>Western Sydney</b>	<b>1050</b>
<b>Essential Energy</b>	<b><i>The distributor should be contacted for information concerning signal frequencies throughout their area.</i></b>	

#### 6.4.1 Blocking System

The customer is responsible for the design of blocking systems. Blocking should be effective under all required conditions, including where sequential steps of capacitor switching are employed.

#### 6.4.2 System Harmonic Blocking

Remember that this equipment will be installed in a power system environment where natural harmonics of 50Hz exist in varying magnitudes depending on location and time of day. In general, the magnitude of the harmonics tends to diminish as the number increases, the 3rd and 5th tend to be “strong” while the 17th and 19th are “weak”. Signal frequencies in common use, are positioned in the upper region of this frequency spectrum.

In many electricity distributor’s systems significant levels of 650Hz (i.e. 13th harmonic) are present at some locations and steps are taken in 750Hz installations to minimise the harmful effects of 650Hz.

The series resonance frequencies required are therefore designed to both increase the impedance of shunt capacitors at the signal frequency and avoid introducing low impedance sinks to system harmonics which may overload equipment.

The required tuning frequency should not be close to any harmonic frequency and still provide a sufficient increase in impedance at the signal frequency.

#### 6.4.3 Low Frequency Ripple Systems

Experience in the industry shows that any effects due to capacitance will be negligible for a ripple frequency less than 400 Hz. However, sufficient space for the installation of harmonic filters should be provided. Nevertheless, each individual application must still be checked and verified by the customer.

#### 6.4.4 Ripple Control Blocking

Although the design of the blocking systems is the responsibility of the customer, in general there are three types of circuit commonly used to increase the impedance of shunt connected capacitors at the signal frequency are known as Blocker, Rejecter and Stopper circuits. Refer to clauses 6.6, 6.7 and 6.8.

Only the Blocker circuit, which acts as a general low pass filter, is not frequency specific. The Rejecter and Stopper circuits use parallel resonance and are tuned to a specific frequency.

## 6.5 Labelling

The power factor equipment must have a nameplate securely fixed to it in an accessible position. The label must include the following information:

- Maker's name.
- Type, serial number (rejecter coils and stopper circuits only).
- System voltage rating.

- Rated 50Hz current.
- Rated capacitor value (inductors only).

The complete equipment assembly should also be labelled for:

- Series resonant frequency (series inductors and rejecter coils only).
- Parallel resonant frequency (rejecter coils and stopper circuits only).

## 6.6 Blocker Circuits

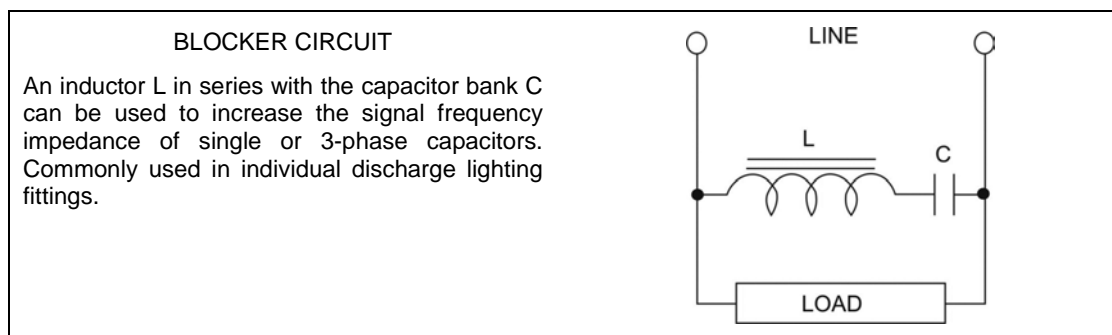

Choose the inductance of the series inductor, (also called a blocking inductor) so that the series resonant frequency does not coincide with a strong harmonic of the mains frequency (eg 5th harmonic, 250Hz and 7th harmonic, 350Hz). The series resonance frequency is fixed by the inductance of the inductor and the capacitance of the shunt capacitor to be blocked.

The required value of tuned frequency must be at least 50% below the ripple frequency plus or minus 5%. For example, in a system where a 750 Hz ripple frequency is used, a value of 190 Hz or 320 Hz ensures that harmonic currents and resultant overvoltages on the capacitor are minimised, at the same time providing adequate blocking to the signal frequencies.

The whole installation should present a predominantly inductive impedance within plus or minus 10% of the ripple frequency.

Successful blocking of the harmonics depends on accurate values of inductance and capacitance.

**Note:** The inductance value should not vary, with up to 200% of the inductors current. There may be considerable difference between the nameplate value and the actual value of capacitance.

Series or blocking inductor circuits are a cost effective and satisfactory method of raising the impedance to signal frequencies, particularly where the capacitor is a single unit, such as in a fluorescent lighting installation.

### 6.6.1 Series Resonant Frequency

Inductors must be designed so that when they are connected in series with the actual capacitor(s) they will be used with, the series resonant frequency of the combination will be at least 50% below the ripple frequency within  $\pm 5\%$ . The voltage of the superimposed frequency is 2% of the mains voltage.

**Note:** The operating conditions of the combination can combine to cause a considerable increase in the RMS current through the capacitor over its normal 50Hz current as determined by the mains voltage and reactance. The voltage rating of the capacitor must be such that it can withstand these conditions in compliance with AS 2897.

## 6.7 Rejecter Circuits

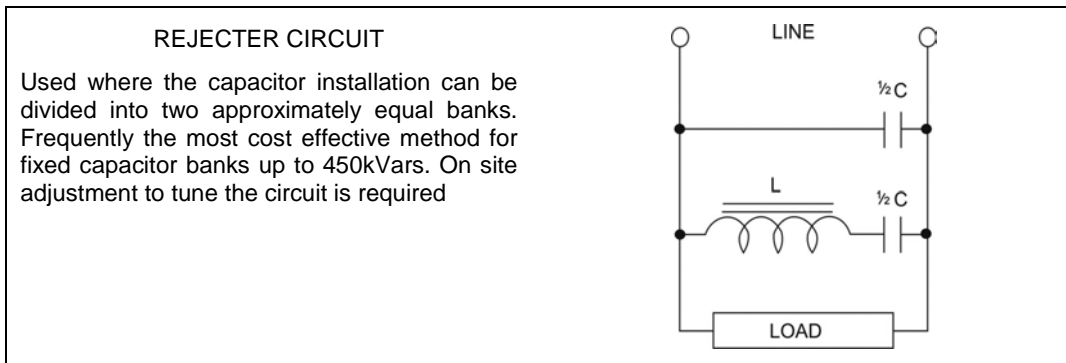

For large correction currents, and where the shunt capacitor bank can be split into two equal sections, the inductor is placed in series with one half of the bank. The inductor then only has to carry half of the 50Hz correction current. These are called Rejecter circuits. They are suitable for fixed capacitor banks up to 450kVar.

Tune the parallel combination of one half of the capacitor bank and one inductor, with the other half of the capacitor bank to parallel resonance at the signal frequency. This offers a high impedance to the control signal.

Tune the inductor on site by air gap adjustment to achieve the required rejection of harmonics and signal frequency.

### 6.7.1 Signal Frequency Impedance

The overall impedance of the capacitor installation with rejecter coils installed must not be less than 75 per cent of the 50Hz reactance of the capacitors within the frequency range used by the electricity distributor in that location, + 1% - 2%. This must be measured with a signal voltage equal to 2% of the 50Hz mains voltage across the terminals of the input capacitor(s).

### 6.7.2 Series Resonant Frequency

The series resonant frequency of the inductor and the capacitor(s) on the side of the inductor remote from the supply must not be less than 500Hz.

## 6.8 Stopper Circuits

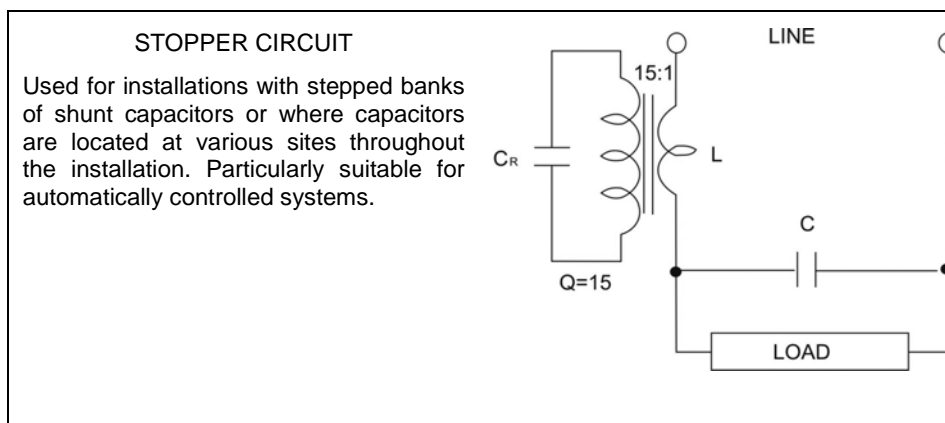

Stopper circuits consist of a self-contained inductor/capacitor unit in series with either the capacitor bank or the line feeding the capacitor bank and the load. Tune the elements to parallel resonance for the signal frequency to be blocked. A series impedance of about ten times the impedance of the inductor or tuning capacitance alone will be the result.

### 6.8.1 Signal Frequency Impedance

The impedance of the stopper circuit alone within the range used by the distributor in that location, + 1% - 2% must not be less than 75% of the impedance of the capacitor alone at 50Hz. A stopper circuit carrying load current in addition to capacitor charging current, must not be less than 120% of the 50Hz impedance of an equivalent load determined by the current rating. The impedance of this equivalent load must be determined by dividing the mains voltage by the rated current of the stopper circuit.

In the case of switched or variable capacitor banks the 50Hz impedance must be the maximum possible capacitance connected at any time. Further, the overall impedance of the stopper circuit and capacitor in any switched position of capacitance must not be less than 50% of the 50Hz impedance of the maximum possible capacitance connected at any time.

The impedance at the electricity distributor's ripple frequency must be measured at rated 50Hz current and with a signal voltage applied equal to 2% of the mains voltage.

### 6.8.2 Series Resonant Frequency

The series resonant frequency of the stopper and capacitor combination must be at least 25% below the ripple signal frequency and at a minimal even harmonic of 50Hz, eg 10th harmonic. In the case of switched or variable capacitors the series resonant frequency with the maximum capacitance connected must not be within 10% of the ripple signal frequency.

Note: This clause does not apply to stopper circuits carrying load current in addition to capacitor charging current.

For transformer coupled stopper circuits, with 1.3 times the rated 50Hz current flowing in the primary winding, the temperature rise of the secondary winding after 4 hours in still air, measured by the winding resistance method, must not exceed 50°C.

## 6.9 Power Factor Correction Equipment Installation

Power factor correction equipment is sometimes added after the initial switchboard installation. The equipment is often in a separate cubicle, wired back to the main switchboard. Most of the cable requirements below will not apply for the few instances where the correction equipment is part of the main switchboard.

Where the power factor correction equipment is installed as part of the main switchboard then the provisions of the AS/NZS 3000 apply.

### 6.9.1 Electrical and Mechanical Protection of Supply Conductors

Normally a main switchboard is located in its own dedicated switchroom or an allocated area of a plant room or floor. If there is a lack of space in this switchroom or switchboard area the correction equipment may be located remote from the switchboard. In this instance, the interconnecting cables should have electrical protection and isolation devices located on the main switchboard.

The cabling should be clamped in accordance with AS/NZS 3000, to withstand the forces due to fault current. Each individual cable must be adequate to carry the fault current if the cables between the switchboard and the power factor correction cubicle are paralleled and the cables are not protected (where the correction equipment is located in the switchroom). To achieve this each cable's current rating must be no less than 25% of the setting of the upstream protection.

### 6.9.2 Isolation of Equipment

You must be able to isolate the correction equipment by a fault make, capacitive load break switch. It is not acceptable to use a fuse link or the power factor controller to operate capacitor contactors to provide isolation. Each consecutive stage of correction will have a time delay before its introduction, so the power factor controller will not provide instantaneous isolation. A circuit breaker or combined switch fuse (CFS unit) is acceptable isolation if it is suitable for switching capacitive currents.

The isolation and protection equipment must be rated for a fault level of 25kA. The electricity distributor may nominate a higher fault level if:

- (a) The customer is situated close to the substation supply, or
- (b) The substation supplying the customer has multiple transformers in parallel.

Labelling of the protection and isolation devices on the main switchboard should show the identity and location of the power factor correction equipment.

### 6.9.3 Clearances around Equipment

Maintain adequate clearances where the power factor correction equipment is installed. If metering equipment is installed nearby you must still have the minimum clearances nominated. If the metering location is a problem it is often more cost effective to relocate the metering than to find an alternative location for the power factor correction equipment. If required, the electricity distributor may relocate the metering equipment at the customer's cost.

### 6.9.4 Frequency Rejection Equipment

In ripple signal areas the equipment must be designed for the ripple frequency or have ripple frequency rejection fitted. Frequency rejection is necessary because the capacitors would otherwise appear as a low impedance to the ripple signal. The equipment must also be labelled with the designed rejection frequency.

Electricity distributor inspectors will check that this frequency matches the ripple frequency of the area in which the equipment is installed. Frequency rejection is necessary to limit the current spread of poor signal sectors within ripple areas. The equipment supplier should test the supply for harmonic content to establish whether harmonic rejection is required to protect the power factor correction equipment. This significantly increases the cost of the correction equipment and need only be installed where necessary.

### 6.9.5 Oil Filled Capacitors

If oil filled capacitors are used they should be manufactured in accordance with AS 2897. Other capacitors are manufactured to IEC 60831-1. If the supplier has used oil filled capacitors with a flashpoint of less than 250°C and with total oil volume of greater than 50 litres, then the capacitor housing or mounting area should have adequate drainage installed, to prevent the spread of oil as specified in the AS/NZS 3000.

### 6.9.6 Labelling of Equipment

The correction equipment should be labelled as specified in clause 6.5.

### 6.9.7 Power Factor Monitoring

The current transformer (CT) used to monitor the installations power factor should be mounted where it will accurately reflect the power factor detected by the electricity distributor's metering. Mounting the power factor correction CT close to the electricity distributor's CTs is acceptable, provided that it does not interfere with the removal of the electricity distributor's CT. The CT should be on the line side of the PCC of the power factor correction capacitors. The electricity distributor must approve the location.

### 6.9.8 The Power Factor Controller

One power factor correction controller is often installed for two or more services. In these situations the power factor correction controller should make sure that no one service has a leading power factor. If the controller fails, it should give the installation a lagging power factor.



# 7 HIGH VOLTAGE CUSTOMER INSTALLATIONS

---

## 7.1 Introduction

This Section outlines the procedures and requirements for the supply of electricity at voltages higher than 1000 V AC.

This section is to be considered in conjunction with Section 1 of these Rules, the High Voltage Electrical Installations Section of AS/NZS 3000, the electricity distributor's high voltage requirements and Safety Management Systems and applicable Australian or other approved Standards.

Inquiries on high voltage supply and installations should be directed to the electricity distributor's offices.

## 7.2 General Information

Supply of electricity will depend on:

- Availability.
- System constraints.

Customers who take supply at high voltage must bear the costs associated with:

- (a) Transformer energy losses.
- (b) The purchase, installation, operation, testing and maintenance of high voltage equipment.

- (c) Spare equipment.
- (d) Insurance, interest and depreciation.
- (e) Compliance with the electricity distributor's Safety Management System.

Customers must also bear the cost of fees, deposits, charges or capital contributions which may be required by the electricity distributor, subject to the determinations of the Australian Energy Regulator.

## 7.3 Submission of Proposal

Where the electricity distributor has agreed in principle to supply a new high voltage installation, alter or add to an existing high voltage installation, the proponent must lodge a detailed proposal and include the following key points:

- (a) The date at which supply is required.
- (b) Whether temporary or permanent supply is required. If temporary for how long is supply required.
- (c) A locality plan of the property.
- (d) Your proposed system voltage.
- (e) A schematic diagram of the proposed electrical installation.
- (f) Loading details including, load characteristics and duty cycles of equipment.

- (g) Protection and control details.
- (h) The fault level gradients throughout the installation.

Considerable planning time may be necessary for the electricity distributor to consider augmentation and/or an extension to the existing distribution system to accommodate the proposed high voltage installation. This is particularly so where the proposed load is relatively large or is located in a remote and unreticulated area.

Potential high voltage customers are advised not to purchase or install any high voltage equipment before the design and construction programs have been accepted by both parties.

## 7.4 Provision of Facilities for Metering Equipment

All metering equipment will be provided, installed and maintained by the customer subject to the agreed Standard Form Customer Connection Contract and Operating Agreement offered by the electricity distributor in an agreed location which is accessible to the electricity distributor's staff.

The customer must arrange for the supply and installation of the metering equipment, including CTs, VTs and meters, in a suitable location, in accordance with the electricity distributor's requirements and Chapter 7 of the National Electricity Rules.

This equipment must be located within the customer's installation. This equipment must also be accessible to the electricity distributor, via its electricity metering locking system. The customer must provide suitable accommodation for the metering equipment, including adequate lighting and availability of socket outlets and any other facilities stipulated by the electricity distributor.

The general requirements of Section 4 of these rules also apply where applicable.

## 7.5 Customer's High Voltage Installation

### 7.5.1 Connection Point

The HV installation commences at the Connection Point, which is the point agreed between the customer and the electricity distributor.

### 7.5.2 Compliance

The high voltage installation and equipment must comply with the requirements of:

- (a) The HV Electrical Installations Section of the AS/NZS 3000.
- (b) These Service and Installation Rules.
- (c) The distributor's HV requirements.
- (d) The electricity distributor's Safety Management System.
- (e) Applicable Australian or other approved Standards.

#### 7.5.2.1 High Voltage Customer Safety Management Plan

Each HV Customer shall have a High Voltage Installation Safety Management Plan. This plan considers the compliance requirements of the Service and Installation Rules and other relevant codes, guides and plans.

### 7.5.3 Supply Voltage

The electricity distributor will nominate the supply voltage during negotiations. Consult with the electricity distributor for its likely range of voltage conditions and install suitable equipment accordingly.

Transformers should have tapplings similar to those specified for the electricity distributor's transformers. These tapplings enable your electrical installation's voltage level to mirror those available on the supply system.

Momentary voltage dips and spikes may occur and you should:

- (a) Install "line conditioning equipment" for supply to voltage-sensitive equipment.
- (b) Make sure that, when they are used, the over/under voltage relays are designed to avoid unnecessary operation.

### 7.5.4 Fault Levels

AS/NZS 3000 states that the electricity installation must be designed so that it "is capable of performing satisfactorily under fault conditions". The short-circuit current which may occur in your installation is dependent upon:

- (a) The prospective fault level at the Connection Point.
- (b) Any contribution which may be made by large rotating electrical plant connected within the installation.
- (c) Impedances within the installation.

The effect of the short-circuit current must be taken into account in the installation design. The electricity distributor will advise in writing of the maximum prospective fault level on the distribution system at the Connection Point, under normal operating conditions.

The fault level will be used to determine minimum equipment fault ratings. The fault level given is generally higher than will exist initially to provide for system development.

Unless otherwise advised, you must install equipment that meets the following minimum fault levels:

- (d) 11kV nominal supply voltage: 250 MVA.
- (e) Other voltages: refer to the electricity distributor.

The electricity distributor will also advise you of the initial fault level at the PCC so that you can calculate the protection relay settings and anticipated voltage fluctuations.

Your design submission must include details of fault levels assigned throughout the installation.

### 7.5.5 Consumers Mains

Select the size and type of cable (and the terminations) in consultation with the electricity distributor.

Cable selection should take into account the possibility of future load growth and be adequate for the maximum prospective fault level.

### 7.5.6 Bush Fire Precautions

High Voltage installations may represent particular hazards in relation to bush fire risk such as bare overhead lines, earthing systems, expulsion fuses and other protective devices, etc. For further pertinent information refer to clauses 1.15.5, 3.3.1.4 and 3.3.3 of these Rules and the relevant clauses of AS/NZS 3000.

### 7.5.7 Protection and Control of Incoming Supplies

The customer must include protection devices in each incoming supply, as well as the control device required by the AS/NZS 3000.

Protection devices must ensure discrimination with the electricity distributor's protection devices, in the event of a fault on any part of your installation. Include the relevant details of your proposed main protection devices in the design submission.

Where batteries are used to operate the incoming supply circuit breaker's trip mechanism, the battery must be provided with:

- (a) Automatic charging equipment.
- (b) A battery-condition indicator.
- (c) An under voltage alarm.

Refer to Attachment B which sets out the typical details the electricity distributor requires.

### 7.5.8 Testing and Inspection

The customer must arrange and pay for the testing (to the electricity distributor's satisfaction) of all high voltage equipment:

- (a) Within a new installation.
- (b) Involved in the repair, alteration or addition to an existing installation.

The testing must be completed before the electricity distributor may permit the connection of the installation, or any part of it, to their supply.

The customer must provide the electricity distributor with copies of all test reports indicating that the equipment has passed the required tests.

The electricity distributor will inspect your installation for compliance with the requirements of AS/NZS 3000 and relevant standards.

The person responsible for carrying out the work is required to submit the installation particulars on the relevant notification of electrical work form.

### 7.5.9 Operation of the Customer's High Voltage Installation

The customer is responsible for the operation of the high voltage installation, including any switching of the customer's equipment.

The prospective high voltage customer shall establish and document effective operational procedures as part of their High Voltage Customer Safety Management Plan.

The electricity distributor will agree to supply you at high voltage, only if you have either:

- (a) Trained staff; or
- (b) A trained electrical contractor

available and qualified to safely operate the high voltage switchgear.

The customer must provide the required safety and operating equipment for people working on the electrical installation. Refer to these Rules outlined in AS 2467 'Maintenance of Electrical Switchgear'. Attachment A of this publication must be read in conjunction with this standard.

### 7.5.10 Maintenance

The customer must maintain the high voltage installation to ensure the electrical equipment is always in sound operating condition. It must be maintained to safely perform the functions for which it is designed.

The following publications are relevant in this regard:

- (a) AS 1940 'The storage and handling of flammable and combustible liquids'.
- (b) AS 2467 'Maintenance of Electrical Switchgear'
- (c) AS 1883 'Guide to maintenance and supervision of insulating oils in service'.
- (d) AS 1767 'Insulating oil for transformers and switchgear'.
- (e) Electricity Supply (Safety and Network Management) Regulation 2014.
- (f) IEC 61230 Ed1.0 (Bilingual 1993) Live Working – Portable equipment for earthing or earthing and short-circuiting

Before working on the installation it must be earthed. The customer must provide suitable direct earthing equipment, or use equipment with built-in earthing facilities.

### 7.5.11 Power Factor Correction

The customer must maintain the power factor at all metering points at a value not less than 0.9 lagging (Customers supplied at a voltage in excess of 50 kV refer to the National Electricity Rules). You should allow for power factor correction equipment in the initial design, refer to clause 1.16.11.

---

## ATTACHMENT A - SCHEDULE OF MINIMUM OPERATING PROCEDURES AND SAFETY EQUIPMENT - HV CUSTOMER INSTALLATIONS

---

Customers taking supply at high voltage must employ adequately trained staff or contractors. You must establish operating procedures and provide safety equipment to ensure the safe performance of all work on your installation.

All operating procedures must meet the overall conditions of AS 2467 'Maintenance of Electrical Switchgear' namely:

1. The High Voltage Installation (HVI) responsible person must have a documented set of electrical safety rules covering all aspects of operating the high voltage installation. The Safety Rules documented in Appendix A of AS 2467 'Maintenance of Electrical Switchgear' is the minimum requirement.
2. The HVI responsible person must provide all persons engaged in work on your high voltage electrical substations and/or installation with a copy of the electrical safety rules.
3. The HVI responsible person must prominently and permanently display the installation's high voltage system operating diagram in each high voltage electrical substation.
4. The HVI responsible person must provide and cause the operators to be trained in the use of:
  - (a) high voltage earthing equipment designed to facilitate the earthing of all types of high voltage equipment within the installation
  - (b) insulating mats, screens and other similar equipment necessary for the safe operation of the high voltage installation.
5. The HVI responsible person must provide testing equipment to prove that high voltage mains and apparatus are dead.
6. The HVI responsible person must provide appropriately coloured tape barriers and stands to display access permits clearly identifying isolated, proven de-energised and earthed sections of the high voltage installation on which work can safely be performed.
7. The HVI responsible person must provide labelled storage facilities as close as practicable to the point of use for the equipment described in items 4 to 6 inclusive.
8. The HVI responsible person must display a safety poster prominently and permanently in each high voltage station within the installation. The poster must outline resuscitation methods and provide instruction in the release of persons from contact with live conductors.
9. The HVI responsible person must provide "access permit forms" to facilitate the monitoring of all persons accessing isolated sections of your electrical installation, to perform work and to ensure all such persons are clear prior to re-energising of the isolated section of the installation.
10. The HVI responsible person must ensure that only persons trained in the operation of the installation perform switching within the high voltage installation, and issue access permits authorising persons to work on isolated and earthed sections of the installation.
11. If the HVI responsible person requires isolation of the electricity distributor's high voltage supply(s), the electricity distributor will ask you to complete an "Operating Agreement". This agreement must be between your authorised operator and the electricity distributor's system controller.

The customer must submit documentation to the electricity distributor outlining the practices, procedures and equipment proposed to be operated, to ensure the high voltage installation is managed in a safe and responsible manner.

For assistance with the written submission and formulation of the required HV switching and safety procedures consult the local electricity distributor's Safety Management System.

White tape is impractical for snow prone areas.

## ATTACHMENT B - PROTECTION DETAILS REQUIRED FOR NEW OR ALTERED HV CUSTOMER INSTALLATIONS

The electricity distributor will assess the proposed protection scheme(s). The customer must provide the following detailed information:

1. Single line diagram of the high voltage installation, including main transformers winding configurations, eg 33kV Delta-11kV Star.
2. Loading details, eg maximum expected load, load characteristics, duty cycles, large motor starting details, etc.
3. Where the incoming protection device is a fuse:
  - (a) Rated current of fuse.
  - (b) Rated breaking current of fuse.
  - (c) Make and type of fuse.
  - (d) Current-time characteristic curves.
4. Where the incoming protection device is a circuit breaker:
  - (a) A control and protection schematic diagram of the incoming circuit breaker(s).
  - (b) Make, type, rated load current and rated fault MVA or rated breaking current of incoming circuit breaker(s).
  - (c) Details of protection relays used, including:
    - i) Make and type.
    - ii) Setting range.
    - iii) Characteristic curves.
    - iv) Thermal ratings of input circuit.
    - v) Tripping and control supply details.
- (d) Protection current transformer details including:
  - i) Make and type.
  - ii) Primary current rating.
  - iii) Secondary current rating.
  - iv) CT class.
  - v) Short time rating.
  - vi) Length and size of secondary circuit wiring.
  - vii) Proposed location.

Note: CTs which utilise primary tapplings for ratio changes are not acceptable. CTs located within a transformer tank or bushings are not acceptable.
5. Protection details of the next line of protection within the installation, so that a realistic grading can be achieved.
6. Voltage transformer details including:
  - (a) Make and type.
  - (b) Primary voltage rating.
  - (c) Secondary voltage rating(s).
  - (d) Category of performance.
  - (e) Rated burden.
  - (f) Accuracy class.
  - (g) Rated voltage factor and rated duration.
7. Estimated date when protection is to be commissioned.

# 8 ALTERNATIVE SOURCES OF SUPPLY

## 8.1 Introduction

All privately owned generating installations (whether stand-by or parallel generation) connected to the distribution system must comply with all statutory and regulatory requirements, including:

- (a) AS/NZS 3000.
- (b) AS/NZS 3010.1 'Electrical installations - supply by generating set Part 1: Internal combustion engine driven set'.
- (c) These Rules.
- (d) The electricity distributor's customer connection contract.
- (e) The National Electricity Rules.

The electricity distributor may disconnect your generating equipment from their distribution system if:

- (a) The equipment is dangerous to the electricity distributor's staff or representatives.
- (b) The continued operation of the equipment is dangerous to the integrity of the electricity distributor's distribution system.
- (c) The equipment adversely affects other customers.

All enquiries regarding alternative sources of supply must be directed to the electricity distributor.

## 8.2 Costs

Subject to the relevant determinations of the Australian Energy Regulator and/or provisions of the National Electricity Law, the customer may be required to pay for all costs incurred by the electricity distributor resulting from the installation of private generating plant. These may include the provision of equipment to:

- (a) Record the operation of the plant.
- (b) Control and protect the electricity distributor's distribution system.

The customer should not spend any money on the proposed generating plant or its installation until:

- (a) The conditions under which the electricity distributor agrees to the connection and intended use of the plant have been received, or
- (b) The electricity distributor's conditions of use and connection have been received.

## 8.3 Stand-By Generating Plant - General

For the purpose of this section, the terms STAND-BY GENERATING PLANT or STAND-BY GENERATOR mean private generating equipment installed to supply or partly supply an electrical installation which is normally supplied from the electricity distributor's distribution system.

### 8.3.1 Conditions of Use

Stand-by generating equipment must only be used under the conditions agreed to by the electricity distributor.

In general, stand-by generating equipment must not be used to operate in parallel with the electricity distributor's distribution system unless it complies with the requirements of Clauses 8.4 or 8.5.

Applications to connect generating systems intended to operate in parallel with the distribution system will be individually assessed. Connection of these systems must be approved by the electricity distributor and meet the requirements of Clauses 8.4, 8.5 and 8.6.

Systems which limit power output in accordance with voltage rise will be considered.

Inquiries or proposals for generation of electricity into the network shall be directed to the electricity distributor.

### 8.3.2 Spacing for Conductors

Conductors must be suitably spaced from all the other conductors of the installation, to limit the damage to the customer's electrical installation if an internal generator fault occurs.

### 8.3.3 Changeover Equipment for Non-Parallel Operation

The connection of the stand-by plant to the electrical installation should normally be made on the load side of the electricity distributor's metering equipment. This is so the electricity distributor's metering will not meter the generated energy. However, this may be unavoidable where an installation has multiple customer metering. Typical arrangements are shown in Figures 8.1 and 8.2.

Switchgear to facilitate manual or automatic changeover in the event of interruption to the electricity supply should be located on or adjacent to the switchboard controlling that part of the electrical installation to be supplied from the private generating plant.

If automatic changeover uses contactors or circuit breakers, arrange them so that opening any switch that controls that part of the installation is safe. Do not create a situation where the opening of any switch controlling that part of the electrical installation intended to be supplied from the stand-by generating plant could be unsafe. Contactors or circuit breakers for automatic changeover must meet the requirements of AS/NZS 3010.1. Provide a switch to isolate the stand-by generating plant from the installation.

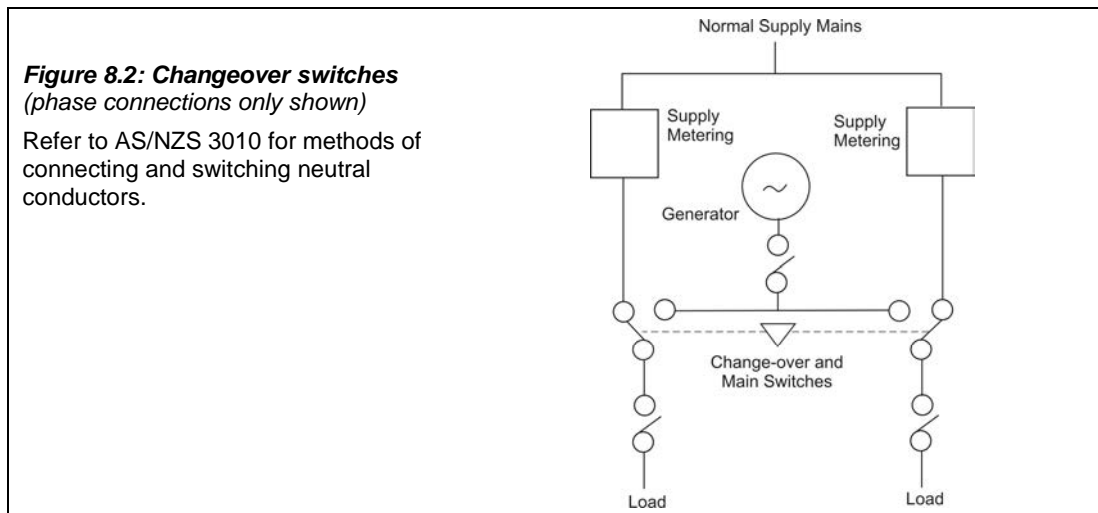
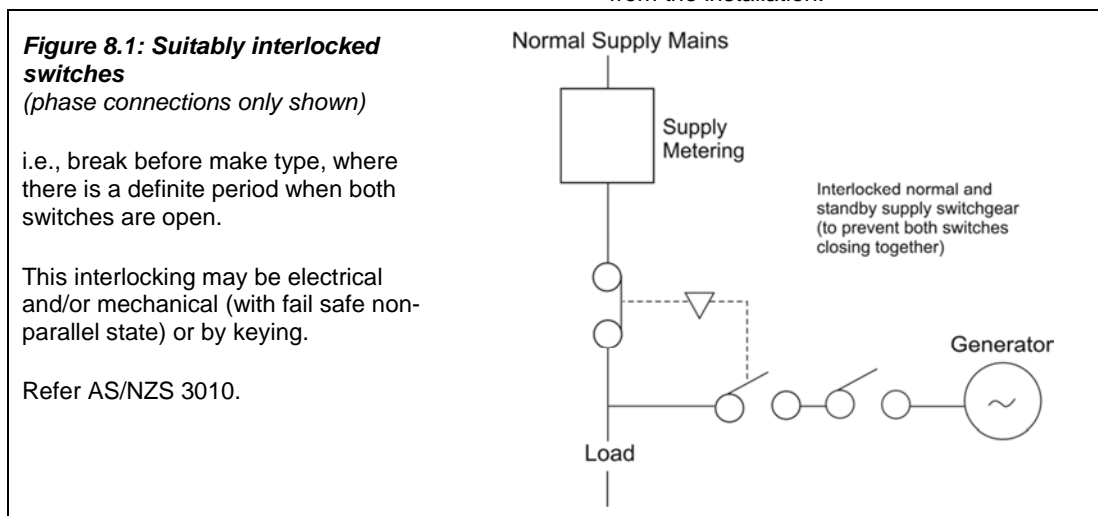

**8.3.4 Switching the Neutral**

Correct sizing of the earth and neutral conductors for a permanently connected generator set is essential as these conductors form the loop that carries the earth fault currents. Refer to Table 8.1 for correct sizing of these conductors.

**8.3.4.1 Principles**

The switching of the generator neutral may be required to avoid multiple MEN connections.

The normal supply neutral must not be switched.

**Table 8.1: Neutral and Earthing Conductors**

Size of Active Conductors	Minimum Size of Connecting Conductors
Not larger than 120mm <sup>2</sup> copper or 185mm <sup>2</sup> aluminium	Not smaller than half the largest active conductor, and in any case, not smaller than 25mm <sup>2</sup> copper or 35mm <sup>2</sup> aluminium.
Exceeding 120mm <sup>2</sup> copper or 185mm <sup>2</sup> aluminium	Not smaller than one quarter of the largest active conductor and in any case not less than 70mm <sup>2</sup> copper or 95mm <sup>2</sup> aluminium.

Note: The minimum size of connecting conductors may be reduced from 25mm<sup>2</sup> Copper and 35mm<sup>2</sup> Aluminium to 10mm<sup>2</sup> Copper and 16mm<sup>2</sup> Aluminium respectively for generating units up to and including 5kVA.

**8.3.5 Multiple Generators**

The harmonic current produced by the generator will flow through the neutral under normal operating conditions. Where dissimilar generators are operated in parallel, steps shall be taken to limit the circulating current in the neutral connection between the generators. The circulating current must be taken into account when determining the size of the neutral conductor.

The customer must discuss the method of interconnection with the electricity distributor if multiple generators are to be connected in parallel.

The methods for interconnection will vary with the size of the site and whether or not all the generators are to be connected at the same switchboard. Larger sites may have generation at multiple locations, whereas smaller sites may have their generators located at the one position. Refer to AS/NZS 3010 for various changeover requirements.



## 8.4 Requirements for Stand-By Generator Synchronise Close Transfer Trip

Generator Synchronise Close Transfer Trip (SCTT) allows transfer to generator supply without complete disconnection of the load.

Customers who wish to use SCTT operation with their stand-by generation must also provide a letter stating the operating conditions of the generator. The operating conditions must specify that the generator will be used as a stand-by supply and will only run in parallel with the electricity distributor's supply system for extended periods if the conditions of Clause 8.5 are met.

The customer must provide the electricity distributor with the following details of the equipment:

- i) Site electrical drawings.
- ii) The protection settings of circuit breaker transfer switches and interlocking arrangements.
- iii) Earthing provisions.
- iv) The proposed installation date.
- v) The size of the generator.

Note: All sources of supply, at the time of synchronisation, must be considered when designing the fault capacity of the system.

### 8.4.1 SCTT Operating Procedure

The time period for operating in parallel with the distribution system during the disconnection or reconnection function of the SCTT for any occurrence should not be longer than 1 second for each operation. The short transfer period eliminates the need for protection against reverse power flow and vector shift.

The period for disconnection includes:

- (a) Closing the generator isolating device to the distribution system once generator and mains supply are synchronised.
- (b) Isolation from the distribution system and transfer of the load to the generator.

The period for reconnection includes:

- (a) Transferring the load from the generator to the distribution system once generator and mains supply are synchronised.
- (b) Disconnecting the generator.

### 8.4.2 Additional Protection

Apart from the protection requirements in AS/NZS 3010, the only additional protection required is a check synchronisation relay which must be provided to monitor manual synchronisation where used.

Switchboards must be labelled to AS / NZS 3010 Electrical installations—Generating sets.

An indicator on the main switchboard must clearly show the generator and electricity distributor's supply system status.

The electricity distributor will approve and inspect the installation before the generator is commissioned. A test operation may be necessary.

When it is necessary for the electricity distributor's System Operator to be informed of a stand-by generator run period, a minimum of one hours notice is desirable advising of the starting time and duration before commencing each run period. The customer representative must provide a contact number and be available for the duration of the run period.

The customer must provide details of the maintenance schedule of the generator protection devices if requested. The customer must keep records; they must be available upon request.

## 8.5 Requirements for Generator Parallel Operation

This clause covers the use of a generator for extended parallel operation.

Customers must provide a statement of the operating condition of the generator. This will specify that the generator may be run in parallel with the electricity distributor's supply system for extended periods as agreed with the electricity distributor.

The customer must provide the electricity distributor with the following details of the equipment:

- i) Site electrical drawings.
- ii) The protection settings of circuit breaker transfer switches and interlocking arrangements.
- iii) Earthing provisions.
- iv) The proposed installation date.
- v) The size of the generator.

### 8.5.1 Operating Procedure

The procedure for operating in parallel with the electricity distributor's distribution system for any occurrence will include:

- (a) Closing the generator isolating device to the distribution system once in synchronism.
- (b) Increasing the generator load to the desired level.
- (c) Run for period arranged.
- (d) Decrease the generator load and isolate generator from the distribution system.

### 8.5.2 Additional Protection

The minimum interconnection protection requirements to allow parallel operation are:

- (a) Over and under voltage protection relays with appropriate time delays (under voltage protection to prevent generator output being transferred to the electricity distributor's distribution system in the event of low or no supply system voltage).
- (b) Manually initiated, fully automatic synchronising equipment.
- (c) Overcurrent and earth fault protection. The protection setting must be suitable for the rating of the machine, the method of earthing and the current capability of the affected circuits.
- (d) A supervised battery supply for relays and tripping.

**Note: Settings on these devices should be approved by the electricity distributor prior to the generator being used in parallel mode.**

You must also provide devices to protect the generator from abnormal operating conditions. Devices shall include (as a minimum) protection against:

- i) Reverse Power (Failure of Prime Mover).
- ii) Loss of Excitation (Pole Slipping).
- iii) Loss of Mains (Anti-Islanding).

Further protection may be installed as required by the generator manufacturer or consultant. Typical examples are listed as follows:

- i) Negative phase sequence.
- ii) Rotor earth fault.
- iii) Differential protection.
- iv) Thermal overload.

Switchboards must be labelled as in clause 8.7.

An indicator on the main switchboard must clearly show the generator and electricity distributor's supply system status.

The electricity distributor will approve and inspect the installation before the generator is commissioned. A test operation may be necessary.

When it is necessary for the electricity distributor's System Operator to be informed of a stand-by generator run period, a minimum of one hours notice is desirable advising of the starting time and duration before commencing each run period. The customer representative must provide a contact number and be available for the duration of the run period.

If the paralleling adversely affects the quality of supply to other customers, correct the operation of the generator before any further parallel operation.

The customer must provide details of the maintenance schedule of the generator protection devices if requested. The customer must keep records; they must be available upon request.

Manual synchronisation is prohibited, unless monitored by a check synchronisation relay.

## 8.6 Small Scale Parallel Customer Generation (via Inverters)

### 8.6.1 Introduction

This clause outlines installation requirements for small scale generation facilities on premises of customers connected to the distribution system (grid) via an inverter. The generation source is most commonly solar photovoltaic (PV), but these requirements are applicable to other sources such as battery storage systems.

The generation source must remain isolated from the distribution system until appropriate metering has been installed.

#### 8.6.1.1 System Capacity Rating

The rating shall be determined by the inverter export capacity rating which shall take into account an approved export limiting system. See Clause 8.6.3.

#### 8.6.1.2 Applicability

This Clause covers single and three phase generators rated at 10kW per phase maximum, larger generators will require special negotiation and approval by the electricity distributor, refer to clauses 8.6.4 and 1.10.13.

#### 8.6.1.3 Voltage Rise

The voltage rise on the service, consumers mains and the conductors between the main switchboard and the inverter terminals must be calculated prior to installation. Clause 8.6.1.3, Figure 8.5 and Tables 8.3.

#### 8.6.1.4 System Voltage Limit

If the 10 minute average voltage at the main switchboard (measured with reference to AS 61000.3.100) exceeds 253V with no load or generation connected the electricity distributor should be contacted.

#### 8.6.1.5 Connection Configuration

These installations may be connected with:

- gross metering where all the electricity generated and supplied to the distribution network is recorded, Figure 8.3; or
- net metering where some or all of the electricity generated is used by the customer with only the net amount supplied to the distribution network being recorded, Figure 8.4.

Buy back tariff availability is the responsibility of the electricity retailer.

### 8.6.2 Responsibilities

The customer is responsible for the design, installation and maintenance of private generation facilities. The installation must comply with all relevant Australian Standards, including:

- AS/NZS 3000.
- AS 4777 - Grid connection of energy systems via inverters: series of standards.

- AS/NZS5033, Installation of Photovoltaic Arrays.
- ENA Guides to PV/Inverter Energy Systems
- These Rules.
- Requirements of the electricity distributor.

### 8.6.3 Export limiting Systems

The installer or distributor may propose an export limited system to avoid upgrades of the network or parts of the customer's installation. The nominated export limit may be based on a 1% voltage rise limit or some other 'agreed' approach and is to be documented on both the voltage rise calculation and the single line diagram submitted with the application.

Zero Export Systems may also be proposed in order to expedite the approval process, or assist where solar penetration rates are high.

### 8.6.4 Approvals Documentation

The inverter and protection equipment must be approved in writing by the electricity distributor prior to connection. The electricity distributor will advise its requirements upon receipt of an application for connection. The customer must provide all appropriate documentation at the time of application for connection, including:

- Single line diagram of the Alternating Current (AC) side of the inverter, showing the PCC, refer to clause 8.6.10.
- Full description of all protection equipment proposed to be installed, including test results. The electricity distributor may also require ongoing periodic verification tests.
- Systems incorporating battery storage shall indicate this in the application and on the single line diagram.

Generating systems with a rating greater than 5kW shall not be connected to single phase unless given approval by the electricity distributor. Refer to Clause 8.6.8.

The application for connection and relevant Certificate of Compliance Electrical Work must include full details of the inverter rating and Certificate of Suitability certification number.

#### 8.6.4.1 Information Required for Systems Greater than 5kW Urban and 3kW Non-Urban

Applications for systems with a single phase rating greater than 5kW in urban areas or 3kW in non – urban areas must submit the following information (in addition to the requirements above for approval prior to the system being connected to the network).

Details of the voltage rise calculations for each of the three components of the generating system that indicate the system will operate correctly and not cause any adverse effects on the customers installation. The three components are the:

- (a) Service;
- (b) Consumers mains; and
- (c) Conductors between the main switchboard and the inverter terminals.

See Clause 8.6.1.3, Figure 8.5 and Tables 8.3 and 8.4 for further details.

### 8.6.5 Metering Requirements

For metering requirements refer to section 4.

A metering installation compliant with the National Electricity Rules must be installed before energisation. Refer to your metering provider for details.

### 8.6.6 Construction Permits

The customer must obtain any authorisation or permits required for the connection and operation of the generating equipment and interconnection facilities. This may include local government rezoning or building permits.

### 8.6.7 Islanding

The customer must prevent the situation where, intentionally or unintentionally, inverters maintain a supply to the distribution system after the distribution system supply has been de-energised. Loss of grid supply may be unplanned (blackout) or planned (for work on the street mains).

Supply to the grid from islanded installations creates serious safety issues, quality of supply problems for other customers and the possibility of equipment damage.

Installations may be designed to continue to operate with supply either from storage such as batteries or from alternative energy sources. The protection equipment associated with the generation source must be designed, installed and tested to ensure that correct islanding of the installation occurs, refer to clause 8.6.14.

### 8.6.8 Multi-Phase Generating Systems

Generating systems with a rating of greater than 5kW shall not be connected to single phase supply unless given distributor approval.

Small scale generating systems that are connected across multiple phases can be connected via two methods:

#### 8.6.8.1 Three phase connection via an integrated three phase inverter

This is the preferred method as it allows all three phases to be controlled by a single control circuit, and allows for a balanced three phase power output.

#### 8.6.8.2 Multiple Single Phase Inverters

The use of 2 or more single phase inverters across multiple phases is permitted provided all other requirements of clause 8.6 are met.

#### 8.6.8.3 Voltage Rise

Regardless of the connection method applied above, the voltage rise for a multi-phase embedded generation system shall be calculated based on the maximum current imbalance permitted by the inverter control systems and shall meet the requirements of section 8.6.11.

#### 8.6.8.4 Single Phase Supply Conversion to Multi-Phase

Where supply is required to be converted to multi-phase it shall be converted to three phase unless approval is given by the distributor to convert to two phase.

#### 8.6.8.5 Multiple Single Phase Systems on Three Phase Supply

Where 1 or 2 single phase generation systems are to be connected to three phase supply, one generator shall be connected to the phase listed in Table 2.2 or 3.2. The other generator/s are to be on another phase.

Note: this is to reduce the out of balance loading to a minimum.

### 8.6.9 Power Factor Setting

Inverters may alter network voltage levels by varying the output Power Factor (PF). Eg an inverter set as 'Lagging' will absorb Vars and may minimise network voltage rise.

Applications for both 'Static' and 'Dynamic' PF control systems will be considered for their suitability for the proposed location.

### 8.6.10 DC Isolation

An appropriately rated double pole DC isolation device must be provided either close to or internal to the inverter, to isolate the DC source from the inverter and operate simultaneously in both positive and negative legs of the DC supply.

Close attention must be paid to any polarity requirements of the isolation device.

### 8.6.11 Generator Connection Arrangement

The generation system must be connected to a dedicated circuit.

It is preferable for the generation system to directly connect to the main switchboard to simplify future metering arrangements. If this is not practicable, the nearest distribution board may be used to connect the generation system and all up stream switchboards labelled. Refer to Section 8.7.

### 8.6.12 Switching Requirements

The following installation main switches must be of the lockable or sealable form for safe isolation:

- (a) The installation main switch(s) on the main switchboard.
- (b) The generator supply main switch, refer to clause 8.6.16.

### 8.6.13 Conductor Size Requirements

The combined impedance of the consumers mains and service must be low enough to ensure the generation system can operate effectively and export to the PCC without excessive voltage rise within the customers installation.

All wiring shall comply with the requirements of Clause 1.5.3.4 in addition to the following:

- **Service**

The size of the Service shall allow no more than 1% voltage rise (see figure 8.5) on the service. Recommended sizes can be found by using AS/NZS3000 Table C7.

- **Consumers mains**

The size of the consumers mains shall allow no more than 1% voltage rise (see figure 8.5) on the consumers mains. Recommended sizes can be found by using AS/NZS3000 Table C7.

- **Other Conductors**

The total voltage rise between the inverter terminals and the main switchboard shall be no greater than 1% (see figure 8.5).

Table 8.3 shows maximum cable lengths for given conductor sizes that meet the 1% voltage rise requirements.

#### 8.6.13.1 Conductor Size Exception Clause

Whilst it is recommended that voltage rise be kept to a minimum, up to 2% voltage rise may be permitted on any one component (8.6.3.1 a, b or c), if the sum of voltage rise on the remaining two components is less than or equal to 1%.

Explanatory Notes: The calculated voltage rise on two of the components at some installations may be very low, thus suggesting a greater voltage rise on the remaining components be allowed without excessive voltage rise occurring at any point within the installation.

E.g. An installation with a calculated Service voltage rise of 0.6%, a Consumer Main voltage rise of 0.3%, would allow a voltage rise of up to 2% between the inverter and the main switchboard, with a maximum voltage of  $253 + ((0.6\% + 0.3\% + 2\%) \times 230) = 259.67V$  at the inverter terminals, which is below the maximum voltage allowable.

Conductor Element	Voltage Rise	
	(%)	V
Service	0.6%	254.4 (253.0 + 1.4)
Consumer Main	0.3%	255.1 (254.4 + 0.7)
MSB <> Inverter	2.0%	259.7 (255.1 + 4.6)

### 8.6.14 Islanding Protection Equipment

Protection must consist of both active and passive systems. All protection equipment must be type tested for compliance with the requirements of these Rules and the electricity distributor. Refer also to AS 4777.3.

#### 8.6.14.1 Active Islanding Protection

Active islanding protection isolates the generation source from the distribution system in the event of a distribution system supply outage.

An example of this method is frequency drift. In this system the inverter is designed to lock to the distribution system frequency as a reference. The inverter frequency generator must then shift away from the nominal 50 Hz if the distribution system supply is not present, thereby, tripping the Over/Under frequency protection. It is recommended that the direction of frequency shift be downwards.

If the inverter does not have the above frequency drift system the manufacturer must demonstrate an alternate islanding protection feature that is acceptable to the electricity distributor.

**8.6.14.2 Passive Islanding Protection**

In addition to the above islanding protection the customer's generation facilities must have the following minimum protection (in the inverter):

- (a) Over/under frequency.
- (b) Over/under voltage.
- (c) Over current and short circuit protection.

Where the inverter protection is not considered adequate, the electricity distributor may require the installation of backup protection. Where required the backup protection is generally installed in an interconnection protection panel (outside the inverter) and must include:

- (a) Over/under frequency.
- (b) Over/under voltage.
- (c) Circuit opening device.

The over/under voltage and frequency protection settings should be negotiated with the electricity distributor within the limits specified in AS 4777.3 and summarised below in Table 8.2.

**Table 8.2: Over/Under Protection Setting Limits**

	Minimum	Maximum
Frequency	48-50Hz	50-52Hz
Voltage	200V	260V

Relays must be set and calibrated by a recognised relay calibration laboratory to the satisfaction of the electricity distributor. Settings may be either factory set or site programmable.

**8.6.14.3 Security of Protection or Export Limit Settings**

Where the inverter energy system has protection or export limit settings that may be changed via a keypad or switches, adequate security must be employed to prevent any tampering / inadvertent / unauthorised change to these settings. A suitable lock or password system should be used. The electricity distributor must approve any setting changes.

**8.6.14.4 Isolation Time**

The maximum combined operation time of both the passive and active protection systems is 2 seconds after loss of the distribution system supply under all load conditions. The inverter must remain disconnected from the distribution system until the reconnection conditions have been met, refer to clause 8.6.15 Reconnection Procedure.

Disconnection, due to the operation of any of the above protection must be via two separate methods, one of which must be by normally open contacts.

**8.6.14.5 Functional In Service Test of Inverter Protection**

The following in service tests should be carried out by the installing contractor to the satisfaction of the electricity distributor.

**Test Method**

Isolate the generator supply main switch. The inverter should trip by its own internal protection in less than 2 seconds following disconnection from the distribution system supply.

Close the generator supply main switch. The inverter should re-connect after a time delay as per clause 8.6.15. Follow a similar procedure to test the backup protection (where installed).

**8.6.15 Reconnection Procedure**

Automatic reconnection of the generation system onto the distribution system must only occur if the distribution system voltage and frequency are within the protection limits in clause 8.6.14 and these conditions have been maintained for a minimum of 1 minute, or as agreed with the electricity distributor.

**8.6.16 Generator Supply Main Switch**

The generator supply main switch must be located on the switchboard at which the generation source is connected.

**8.6.17 Shut Down Procedure**

Labelling describing the correct shut down procedure in accordance with the relevant Australian Standard shall be provided.

**8.6.18 Storage Systems**

Storage systems such as batteries shall be installed in accordance with the relevant Australian Standards with due consideration given to ventilation, prevention of unauthorised access, and electrical safety.

**Figure 8.3: Example Single Line Diagram Gross Metering (parallel generation source connected at the main switchboard)**

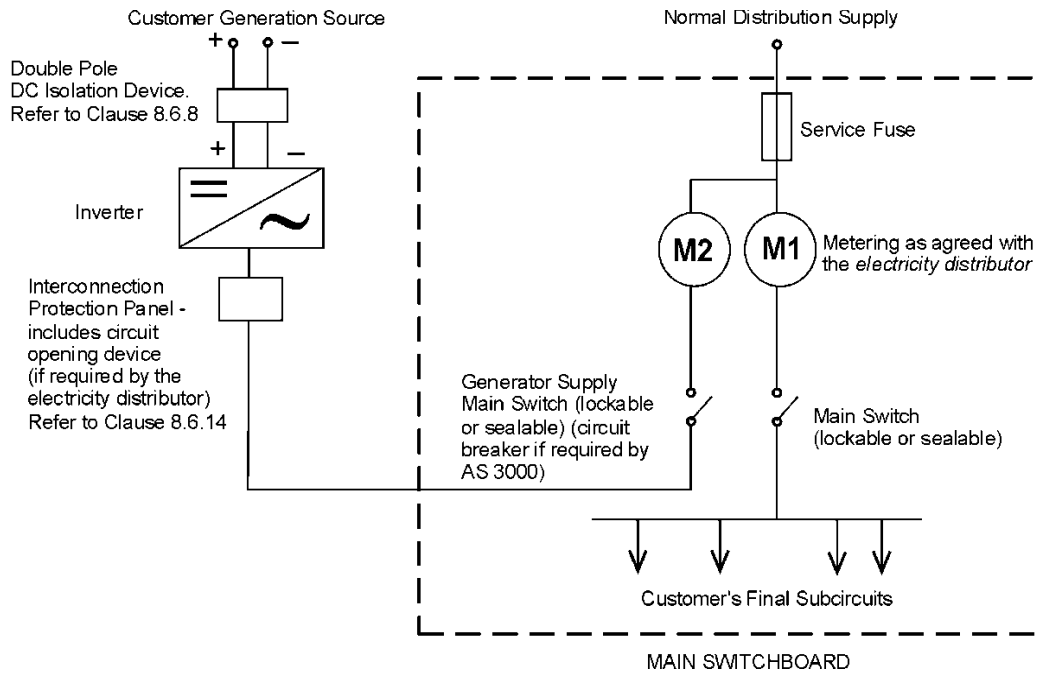

**Figure 8.4: Example Single Line Diagram Net Metering (parallel generation source connected at the main switchboard)**

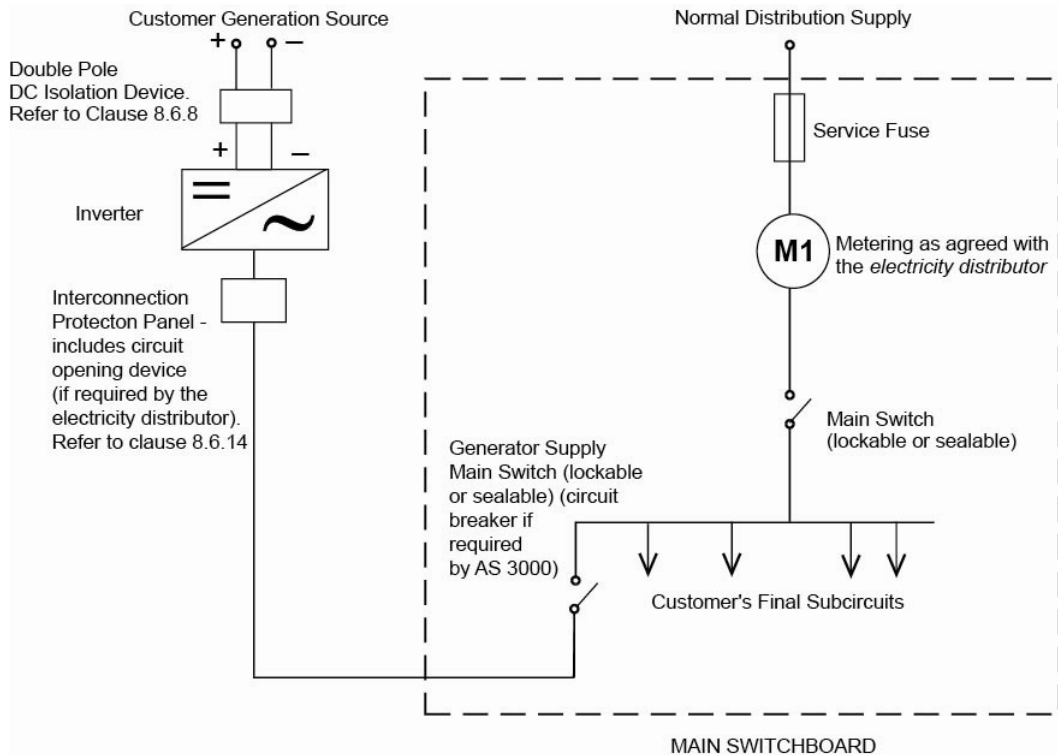

Note: Generator connection through installation main switch.

**Table 8.3: Maximum Cable Lengths for 1% Voltage Rise for various inverter configurations.**

Inverter Configuration		Single Phase	Three Phase	Three Phase
Inverter Rating (kW)		5	5	10
Conductor Current (A)		21.7	7.2	14.5
Cable Conductor Size (mm <sup>2</sup> )	Conductor Material	Maximum Route length (m)	Maximum Route length (m)	Maximum Route length (m)
6	Cu	14	85	42
10	Cu	24	143	71
16	Cu	38	227	113
25	Cu	59	357	179
35	Cu	82	491	246
50	Cu	109	659	329
95	Cu	204	1232	616
25	Al	36	216	108
95	Al	132	794	397

**Table 8.4: Example of Calculating Voltage Rise Requirements**

**Example: Using AS/NZS 3000 Table C7 to calculate Maximum Route lengths:**

A single Phase inverter of 5kW (21.7Amps at 230V) is to be installed. Existing consumers mains is 20 metres of 6mm<sup>2</sup> copper. Will the consumers mains satisfy the maximum 1% Voltage *rise* requirement?

STEP	PROCESS	CALCULATION
1	Look up <b>Am per %V</b> from AS/NZS 3000 Table C7 for 6mm <sup>2</sup> copper single phase	<b>Am per %V = 306</b>
2	Calculate the maximum route length for the conductor for 1% voltage <i>rise</i> .  From AS/NZS 3000 Appendix C4.1, use $L = (\%V_d * \text{Am per } \%V_d) / I$	$L = (1\% * 306) / 21.7 = 14.1\text{m}$  Length is < 20m, therefore need to use larger cable.
3	Repeat calculation for next size conductor (10mm <sup>2</sup> copper).  Use <b>Am per %V = 515</b>	$L = (1\% * 515) / 21.7 = 23.7\text{m}$  Length > 20m so can be used

Note: Am means Ampere metre.



**Figure 8.5: Voltage Rise Limits for installations with embedded generation**

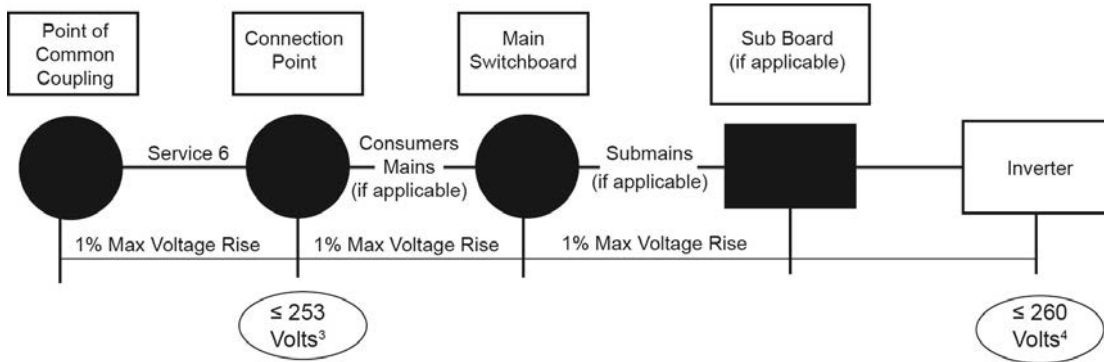

Notes:

1. All requirements are based on the full rated output of the inverter.
2. Based on nominal voltage of 230V.
3. See AS 60038 Table 1
4. Overvoltage anti-islanding protection applies (clause 8.6.14).
5. Existing rules apply for voltage drop due to customer loads (AS/NZS 3000).
6. Combined impedance of consumers mains and service to limit voltage rise- Service & Installation Rules of NSW clause 8.6.13.
7. See Exception Clause 8.6.13.1

## 8.7 Labelling

The customer must supply and install clear and indelible labelling on the installation. As a minimum, labelling should be placed on:

- (a) The switchboard or distribution board that has a generation system connected to it.
- (b) All switchboards including the main switchboard and distribution board(s) upstream of the board that has a generation system connected to it.

Labels should indicate:

- i) The existence of an alternative source of supply.
- ii) The sections of the electrical installation it can supply.

- iii) The point of control.
- iv) The conditions under which the alternative source may be operated.
- v) The conditions of connection and suitable operating arrangements.
- vi) The actual type of generation source installed, as particular generation sources have varied electrical characteristics.
- vii) Whether a storage system eg battery is part of the installation.

The labelling shall comply with the Australian Standards listed in Clause 8.6.2.

The Division of Resources & Energy, NSW Trade & Investment (DRE) is the Convenor and Secretary of the Management Committee and is the notional holder of the copyright of the Rules.

Website: <http://www.resourcesandenergy.nsw.gov.au>

Email: [service.rules@industry.nsw.gov.au](mailto:service.rules@industry.nsw.gov.au)

Service and Installation Rules of NSW

November 2016 Edition

ISBN 978 1 74256 553 8